



Liebert[®] DCD Rear Door Heat Exchanger

User Manual

Up to 50 kW

The information contained in this document is subject to change without notice and may not be suitable for all applications. While every precaution has been taken to ensure the accuracy and completeness of this document, Vertiv assumes no responsibility and disclaims all liability for damages result from use of this information or for any errors or omissions.

Vertiv recommends installing a monitored fluid detection system that is wired to activate the automatic closure of field-installed coolant fluid supply and return shut off valves, where applicable, to reduce the amount of coolant fluid leakage and consequential equipment and building damage. Refer to local regulations and building codes relating to the application, installation, and operation of this product. The consulting engineer, installer, and/or end user is responsible for compliance with all applicable laws and regulations relation to the application, installation, and operation of this product.

The products covered by this instruction manual are manufactured and/or sold by Vertiv. This document is the property of Vertiv and contains confidential and proprietary information owned by Vertiv. Any copying, use, or disclosure of it without the written permission of Vertiv is strictly prohibited.

Names of companies and products are trademarks or registered trademarks of the respective companies. Any questions regarding usage of trademark names should be directed to the original manufacturer.

Technical Support Site

If you encounter any installation or operational issues with your product, check the pertinent section of this manual to see if the issue can be resolved by following outlined procedures.

Visit <https://www.vertiv.com/en-us/support/> for additional assistance.

TABLE OF CONTENTS

1 Important Safety Instructions	1
1.1 Safety Notice	1
2 Unit Code and Component Location	3
2.1 Product Overview	3
2.2 Unit Code	3
2.3 Component Location	7
3 Storage and Transportation	9
4 Installation and Commissioning	11
4.1 Preparation for Installation	11
4.1.1 Check the Device for Shipping Damage	11
4.1.2 Qualified Installation	11
4.1.3 Room Preparation	11
4.2 Headroom and Clearance	11
4.3 Piping and Connection Methods	13
4.3.1 Using Chilled Water Distribution Units (CDU)	15
4.3.2 Using Open Loop Chilled Water Systems	15
4.3.3 Floor Cut Out for Units with Bottom Connections	16
4.4 Assembly Procedure and Tools Required	17
4.5 Insulate Piping	30
4.6 Recommended Pipe Sizes	30
4.7 Chilled Water Connection	30
4.7.1 Strainer	32
4.7.2 Service Valves	32
4.7.3 Balancing Valves	32
4.7.4 Flexible Pipes	32
4.8 Leak Checking	34
4.9 Filling the Unit	34
4.9.1 Bleeding Air from the Liebert® DCD	34
4.10 Housing Integrity	35
4.11 Application Conditions	35
5 Description	37
5.1 General Function	37
5.2 Cooling Principle	38
6 Variants and Options	39
6.1 Vertiv™ Liebert® DCD Assembled to Vertiv™ Liebert® DCM Server Rack	39
6.2 Vertiv™ Liebert® DCDactive Fan Module	39
6.3 Connection Set Liebert® DCD	41
6.4 Spacing Kit and BSP to NPT Adapter	46

7 Maintenance and Repairs	49
8 Disassembly and Disposal	51
9 Customer Service	53
Appendices	55
Appendix A: Technical Support and Contacts	55
Appendix B: Quality Requirements for Water Used in the Vertiv™ Liebert® DCD	56
Appendix C: Checklist for Setting up the Device	58
Appendix D: Functional Check	59
Appendix E: Thermodynamic Checks	60
Appendix F: Performance Charts	61
Appendix G: Submittal Drawings	70

1 Important Safety Instructions

1.1 Safety Notice

NOTICE

Our engineers can give you comprehensive advice in assembling the Vertiv™ Liebert® DCD. Extensive material, functional and quality testing guaranty high benefit and a long lifecycle. Nonetheless, such devices may be hazardous if improperly handled by untrained personnel and if used for purposes they are not intended for.

IMPORTANT! Carefully read this assembly and operational manual prior to assembling and commissioning the Liebert® DCD.



CAUTION: Maintenance work is to be done only by experts. Maintenance and cleaning operations must be done by trained personnel. In order to keep the device in an operationally safe condition and maintain a long life, routine maintenance and cleaning must be done.

NOTE: Operate the Liebert® DCD only in accordance with its specified purpose, within its limits of capacity and approved operating means.



CAUTION: When performing any works on and with the device, please follow:

- Any respectively applicable regulations (such as VDE regulations or other nationally applicable guidelines).
- Any applicable accident prevention regulations (BGV).
- Any respective provisions.
- Any applicable environment protection acts.

Operate the device only in its proper condition. In the event of functional disturbances or deficiencies, the device must immediately be taken out of operation and the operator's responsible person must be informed of its state. The device must only be taken into operation again after the flawless function of the device has been restored.



CAUTION: Hot surface! Defective fans, power supply units or control boards may have run hot. Allow them to cool down before commencing any operations.



CAUTION: Carefully read these Operating Instructions prior to taking this unit into operation.

Apply this unit to the intended use only as described in these Operating Instructions.

This unit must be maintained by a trained electrician. Comply with all local safety regulations.

Any works on the electrical unit must be performed only when disconnected from power. The unit shall be disconnected from power by switching OFF all poles. Safeguard against being switched ON unintentionally. It must be connected to marked sources of power supply only.

If the unit or parts of the unit are damaged, it must be separated from power supply (switch OFF the mains fuse).

The unit or parts thereof must never be exposed to rain or water. Fluids or other foreign matter must be prevented from entering the device through openings in its housing.

The unit must be applied and operated with its intended use of mission critical cooling and be serviced by experienced and qualified service personnel.

No modification of or tampering with these controls, nor any opening of the lid are permissible and release the manufacturer from any warranty and liability.

2 Unit Code and Component Location

2.1 Product Overview

Vertiv™ Liebert® DCD is an air-water heat exchanger that is integrated into the rear door of a server rack. The heat exchanger is suitable for absorbing heat loads from server racks of up to 50 kW. It can be configured in such way that no heat is released to the installation area.

Cooling effect occurs when the server exhaust air passes through the heat exchanger in the rear section of the server rack. The cooling air is moved through the heat exchanger only by the server fans. Liebert® DCD thereby supports the cold room concept in which is the warm exhaust air from servers always led to a cooling device where its temperature is reduced to the temperature level of the server supply air. The supply air for chilled water system flows freely through the installation area.

2.2 Unit Code

The following tables describe the model number for the Liebert® DCD Rear Door Heat Exchanger.

Table 2.1 Liebert® DCD Model Number Example

Model Number - Part 1/2										Model Details										Part 2/2				
1	2	3	4	5	6	7	8	9	10	11	12	13	14	15	16	17	18	19	20	21	22	23	24	25
D	C	D	3	5																				
D	C	D	4	7																				
D	C	D	5	0																				

Table 2.2 Vertiv™ Liebert® DCD Model Number Definition

Code	Definition
1-3	<p><u>Basic unit</u></p> <p>Liebert® DCD is an air-water exchanger that is integrated into the rear door of a server cabinet. The heat exchanger serves to absorb heat loads from server cabinets of up to 35 kW and 50 kW. Thereby, it can be configured in such a way that no thermal loads are released to the installation area.</p>
4-5	<p><u>Nominal cooling capacity</u></p> <p>35 = 35 kW</p> <p>47 = 47 kW (with DCDactive only).</p> <p>50 = 50 kW (cabinet width 800 mm only).</p>
6	<p><u>Cabinet height</u></p> <p>A = For cabinet height of 2000 mm.</p> <p>C = For cabinet height of 2200 mm.</p>
7	<p><u>Cabinet width</u></p> <p>0 = DCDactive fan unit (without cabinet).</p> <p>6 = For cabinet width of 600 mm (not available for DCD 50).</p> <p>8 = For cabinet width of 800 mm.</p>

Table 2.2 Vertiv™ Liebert® DCD Model Number Definition (continued)

Code	Definition
8	<p><u>Cabinet type</u></p> <p>3 = The DCD (passive) unit is equipped with adaptor for 3rd party cabinet</p> <p>0 = The DCD (passive) unit is delivered without cabinet and can be mounted on site on existing cabinet</p> <p>A = Unit will be shipped from factory installed on a cabinet. (no DCDActive)</p> <p>B = DCD with cabinet and DCDActive</p> <p>F = DCDActive fan unit (retrofit or additional item for DCDs without cabinet)</p>
9	<p><u>CW connection - hinge position</u></p> <p>0 = DCDActive fan unit only</p> <p>1 = Unit has chilled water connections from the top left side</p> <p>2 = Unit has chilled water connections from the top right side</p> <p>3 = Unit has chilled water connections from the bottom left side</p> <p>4 = Unit has chilled water connections from the bottom right side</p>
10	<p><u>Cabinet depth</u></p> <p>0 = No cabinet</p> <p>E = The cabinet depth is 1000 mm</p> <p>F = The cabinet depth is 1100 mm</p> <p>G = The cabinet depth is 1200 mm</p>
11	<p><u>Front door</u></p> <p>0 = No cabinet</p> <p>C = With single sheet steel front door 83% perforation, hinged right hand side</p> <p>G = With double sheet steel front door 83% perforation</p> <p>L = With single sheet steel front door 83% perforation, hinged left hand side</p> <p>X = Cabinet without front door</p>
12	<p><u>19" rails front</u></p> <p>0 = No cabinet</p> <p>A = Symmetric with air separation and additional vertical U slots</p> <p>L = Asymmetric with air separation and additional vertical U slots (for width 800 mm)</p> <p>B = Symmetric with air separation (for width 600 mm only)</p>
13	<p><u>19" rails rear</u></p> <p>0 = No cabinet</p> <p>Y = Asymmetric without air separation (for width 800 mm)</p> <p>S = Symmetric without air separation</p> <p>A = Symmetric with air separation and additional vertical U slots (for width 800 mm only)</p> <p>B = Symmetric with air separation (for width 600 mm only)</p> <p>L = Asymmetric with air separation and additional vertical U slots (for width 800 mm)</p>

Table 2.2 Vertiv™ Liebert® DCD Model Number Definition (continued)

Code	Definition
14	<p><u>Bottom plate</u></p> <p>0 = No cabinet</p> <p>L = Cable entry for cabinets with levelling feet</p> <p>R = Cable entry for cabinets with casters</p>
15	<p><u>Rack Base</u></p> <p>0 = No cabinet</p> <p>A = With stationary rack base load rating 1000 kg static height 100 mm (rack height + 100 mm).</p> <p>B = With stationary rack base load rating 1000 kg static height 200 mm (rack height + 200 mm).</p> <p>R = With high load caster, load rating 1000 kg mobile, 1500 kg static on levelling feet, no rack base</p> <p>F = With leveling feet (0-25 mm), no rack base.</p>
16	<p><u>Color</u></p> <p>1 = Visible surface of covers RAL 7035 (light gray)</p> <p>G = Visible surface of covers RAL 7021 (dark gray)</p>
17	<p><u>Side panels</u></p> <p>0 = No cabinet</p> <p>X = Without side panels</p> <p>B = With right + left side panel</p>
18	<p><u>Jumpering depth for front 19" rails</u></p> <p>0 = No cabinet</p> <p>A = Jumpering space 80 mm, useful depth 740 mm</p> <p>D = Jumpering space 123 mm, useful depth 740 mm</p>
19	<p><u>DCDactive upgrades</u></p> <p>0 = No DCDactive</p> <p>N = Standard DCDactive incl. Modbus TCP/IP</p> <p>T = DCDactive Modbus TCP/IP + monitoring (temp, leakage, door) + display</p> <p>B = DCDactive with A/B transfer switch 230VAC incl. Modbus TCP/IP</p> <p>A = DCDactive with A/B transfer switch 230VAC + Modbus TCP/IP + monitoring (temp, leakage, door) + display</p> <p>D = DCDactive with A/B transfer switch 115VAC incl. Modbus TCP/IP</p> <p>C = DCDactive with A/B transfer switch 115VAC + Modbus TCP/IP + monitoring (temp, leakage, door) + display</p>
20	<p><u>Free</u></p> <p>0</p>

Table 2.2 Vertiv™ Liebert® DCD Model Number Definition (continued)

Code	Definition
21	<p><u>Packaging</u></p> <p>P = DCD / DCDDactive packed in cardboard box lying on pallet (max. 4 DCD units or 6 DCDDactive); cabinet/DCD/DCDDactive combination upright on pallet, edge protection, dust cover</p> <p>S = DCD / DCDDactive packed in cardboard box lying on pallet (max. 4 DCD units or 6 DCDDactive), wooden crate; cabinet/DCD/DCDDactive combination upright on pallet, edge protection, dust cover and wooden crate</p>
22	<p><u>SFA</u></p> <p>A = No SFA</p> <p>X = SFAs included</p>
23-25	<p><u>Internal counter</u></p>

2.3 Component Location

Figure 2.1 Component Location

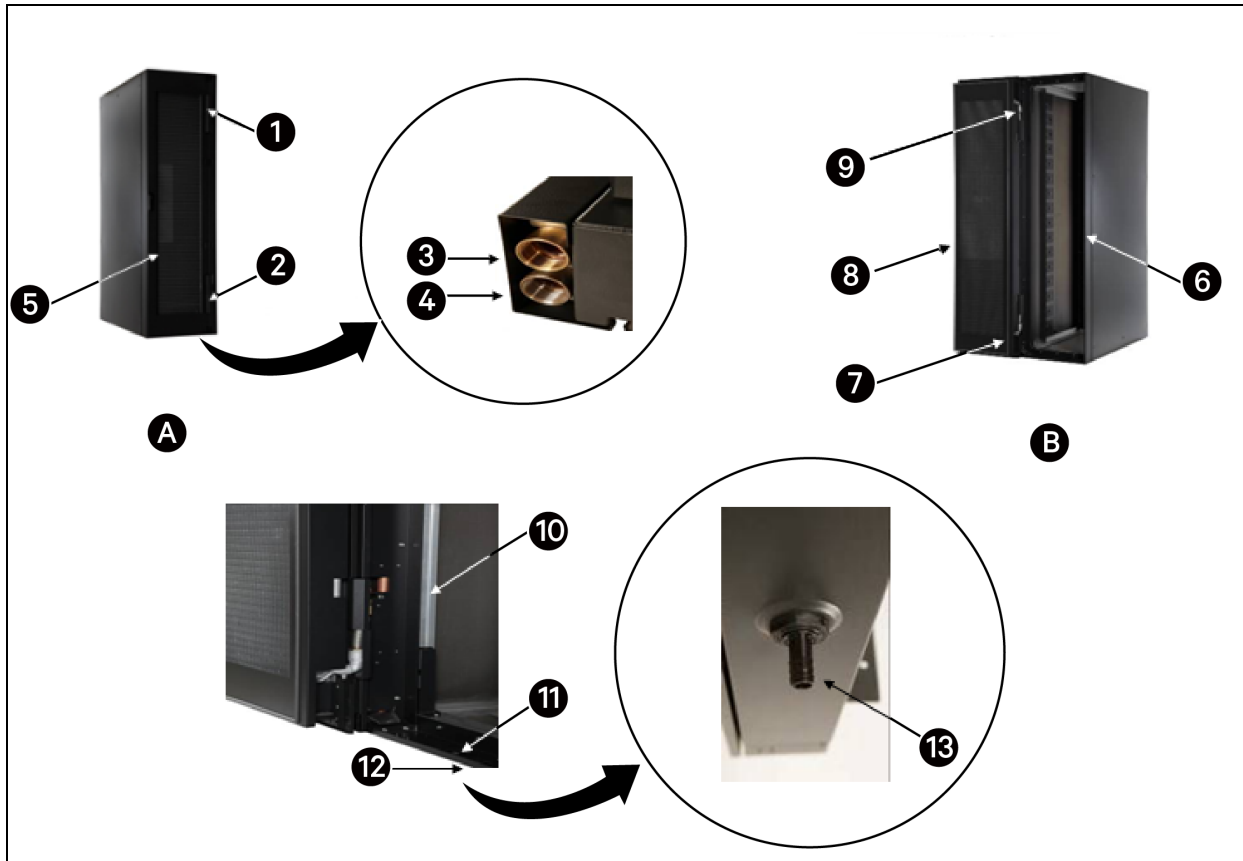

Item	Description	Item	Description
A	Back side of the rack	7	Door lower piping
B	Back side of the rack	8	Door
1	Upper swivel joint cover	9	Door upper piping
2	Lower swivel joint cover	10	Rack frame
3	Chilled water outlet (bottom view)	11	Condensate drain plug
4	Chilled water inlet (bottom view)	12	Condensate tray
5	Handle	13	5/8" Hose barb connection (bottom view)
6	Frame		

This page intentionally left blank

3 Storage and Transportation

- Keep the device in its original packaging, protected from the weather and in dry conditions.
- Protect the working parts from dirt (such as sand, rain, dust).
- Storage temperatures between -30 °C and +50 °C (-22 °F and +122 °F).
- Chilled water circuit must be empty during storage (risk of freeze damage).
- After a long period of storage (more than one year), inspect functionality of water bearing hinges.
- Remove all the packaging before commencing operation of the device.
- Chilled water connections are not to be used as a transport handles.
- When transporting always make sure the device is properly fastened and secured against slipping.

Table 3.1 Unit Weight

Width	Dry Net Weight +/- 5% kg (lb)
	Vertiv™ Liebert® DCD (without rack)
600 mm	Approximately 73 kg (160 lb) for Liebert® DCD35 Approximately 106 kg (233 lb) for Liebert® DCD47
800 mm	Approximately 93 kg (205 lb) for Liebert® DCD50 ¹
Land freight packaging	+40 kg (88 lb)
Seaworthy packaging	+125 kg (276 lb)
¹ DCD50 is for width 800 mm only. For details, see Unit Code on page 3.	

This page intentionally left blank

4 Installation and Commissioning

4.1 Preparation for Installation

IMPORTANT! Before installing the device, it is crucial You check each of the following points. These checks will ensure safe and trouble-free operation of Vertiv™ Liebert® DCD. Perform these tests with great care.

4.1.1 Check the Device for Shipping Damage

Inspect the device upon receipt for damage.

NOTE: When returning device because of shipping damage, use original packaging if possible. If the device is not sent in its original packaging, make certain that the distance between the device and its new packaging is at least 30 mm (1.18").

4.1.2 Qualified Installation

Please find the checklist enclosed in the [Quality Requirements for Water Used in the Vertiv™ Liebert® DCD](#) on page 56 to help with installation. Commissioning can also be done by specialized company. In this case please find the commissioning protocol enclosed in the [Quality Requirements for Water Used in the Vertiv™ Liebert® DCD](#) on page 56.

4.1.3 Room Preparation

The room should be well-insulated and must have a sealed vapor barrier. The vapor barrier in the ceiling and walls can be a polyethylene film. Paint on concrete walls and floors should contain either rubber or plastic. The vapor barrier is the single most important requirement for maintaining environmental control in the conditioned space.

4.2 Headroom and Clearance

Liebert® DCD supports the cold room concept in a data center. The warm air is limited to the plenum between the outlet from the IT equipment and the inlet to the Liebert® DCD heat exchanger. This space should be sealed off from the environment in terms of air tightness so that neither warm cooling air can escape into the room uncooled nor cool room air flows into the Liebert® DCD cabinet.

For the installation of the Liebert® DCD in the rack rows, it is recommended that the surfaces with the air inlet and the surfaces with the air outlet face each other. The arrangement would correspond to a hot aisle cold aisle arrangement in a conventional data center.

Figure 4.1 Air Flow and Liebert® DCD Rack Arrangement

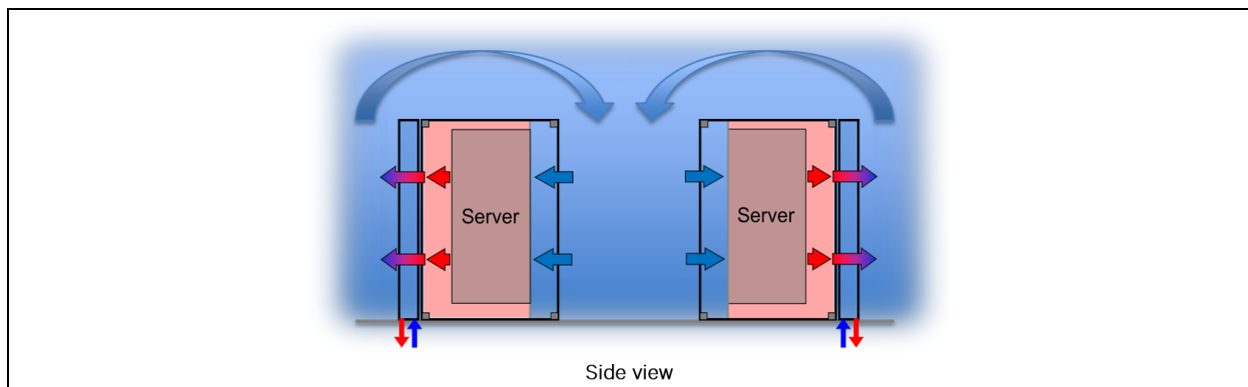

The cooling air mainly flows over the top of racks to the front air intake at room temperature. In order not to obstruct this air flow, the minimum headroom above the racks is described in **Table 4.1** below . The distance to the next rack, wall or other obstacle should not be less than 0.9 m. This minimum distance must be ensured for the unobstructed flow of cooling air, because of the door opening and the service area. The headroom depends on the installed heat dissipation per rack and on the cabinet width. The cross-section of cable trays or pipes must be subtracted when calculating the headroom.

Table 4.1 Minimum Headroom above the Racks

H Minimum Headroom m (ft)					
Heat load [kW]	10	20	30	40	50
Rack width 600 mm	0.25 mm (0.82 in.)	0.5 mm (1.64 in.)	0.75 mm (2.46 in.)	N/A	N/A
Rack width 800 mm	0.2 mm (0.66 in.)	0.4 mm (1.31 in.)	0.6 mm (1.97 in.)	0.8 mm (2.62 in.)	1.00 mm (3.28 in.)

Figure 4.2 Headroom and Clearance

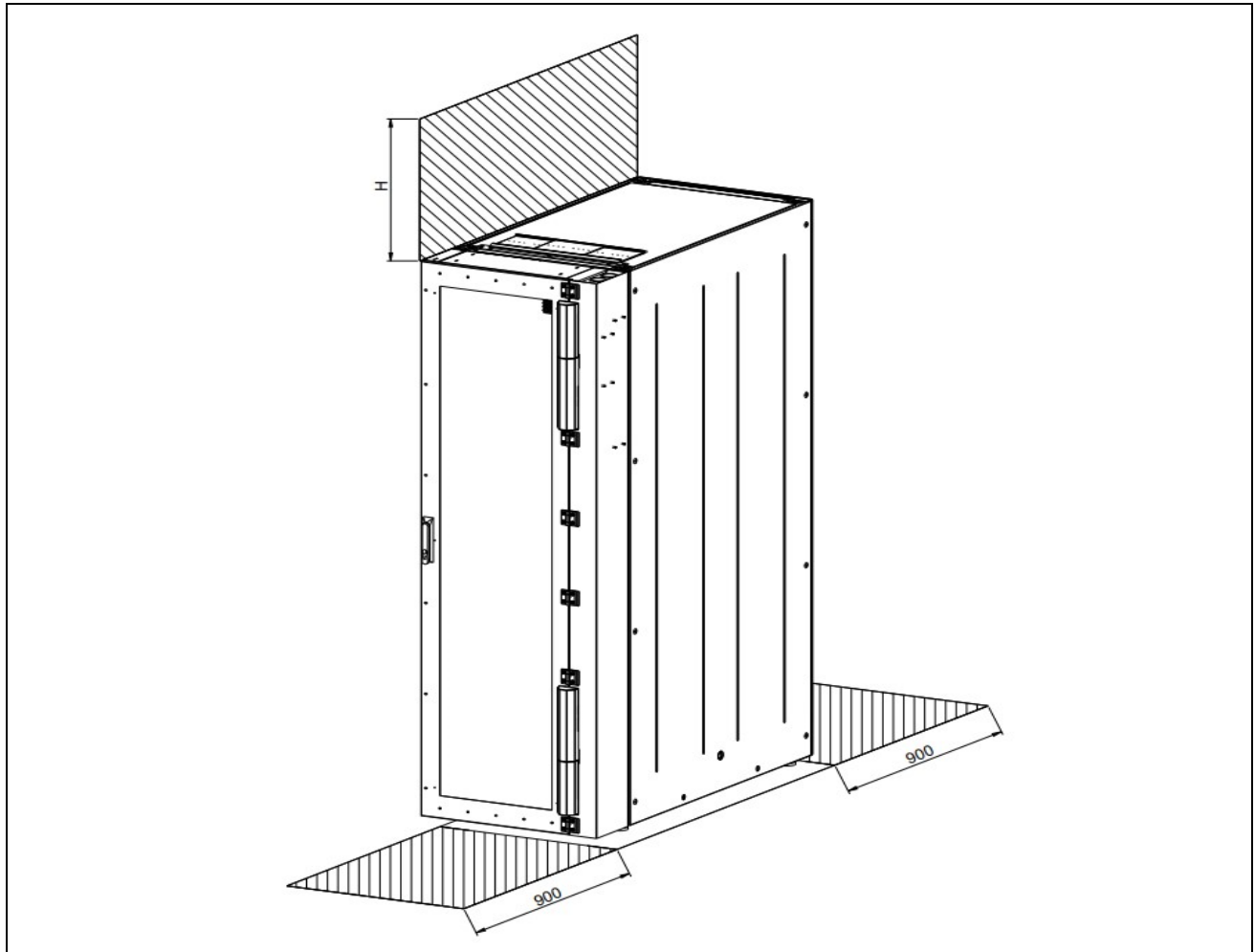

4.3 Piping and Connection Methods

If possible when using a Coolant Distribution Unit, connect the Vertiv™ Liebert® DCD in a ring configuration (see **Figure 4.3** below) or Tichelmann ring (**Figure 4.4** on the next page). In this system the pressure drop for each of the units is approximately the same which results in even cooling performance.

Chilled water installation should be carried out in accordance with local installation regulations and standards. This includes the installation of an expansion tank appropriate to the water volume and temperatures, as well as a safety valve that will trip if the maximum operating pressure of the system is exceeded.

Figure 4.3 Ring Piping

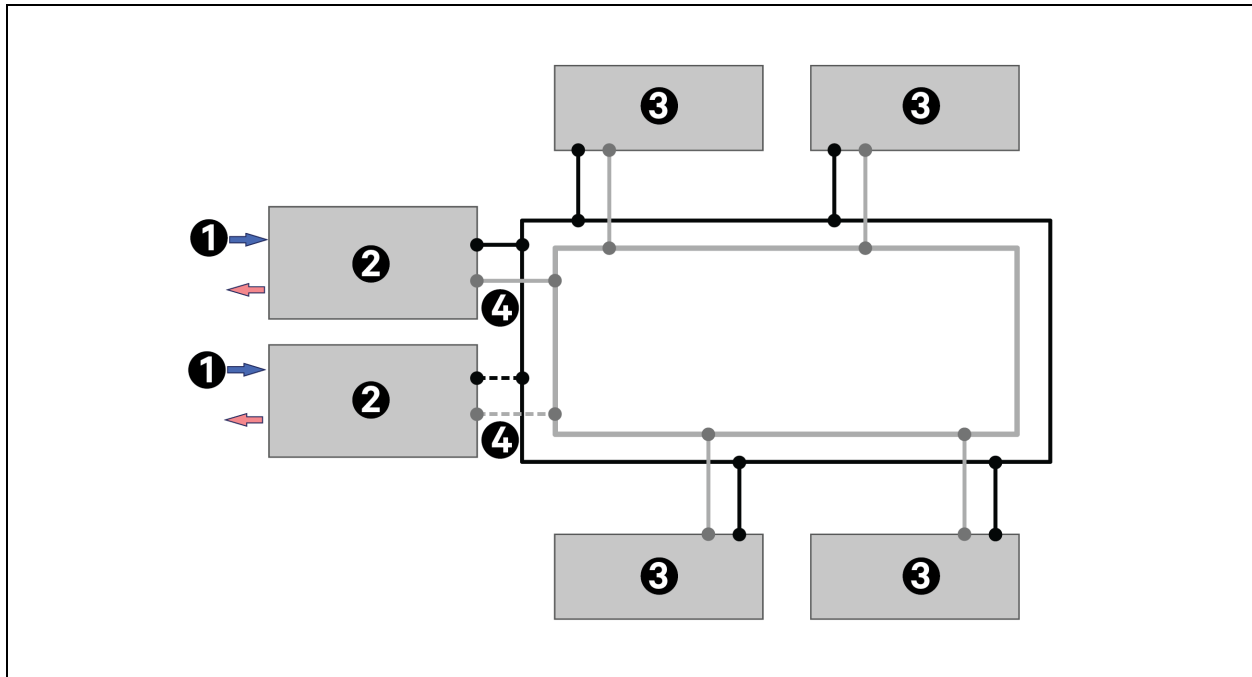

Item	Description
1	Building chilled water
2	Cooling distribution unit
3	Liebert® DCD
4	Thermal expansion (field provided and installed)

Figure 4.4 Tichelmann Ring Piping

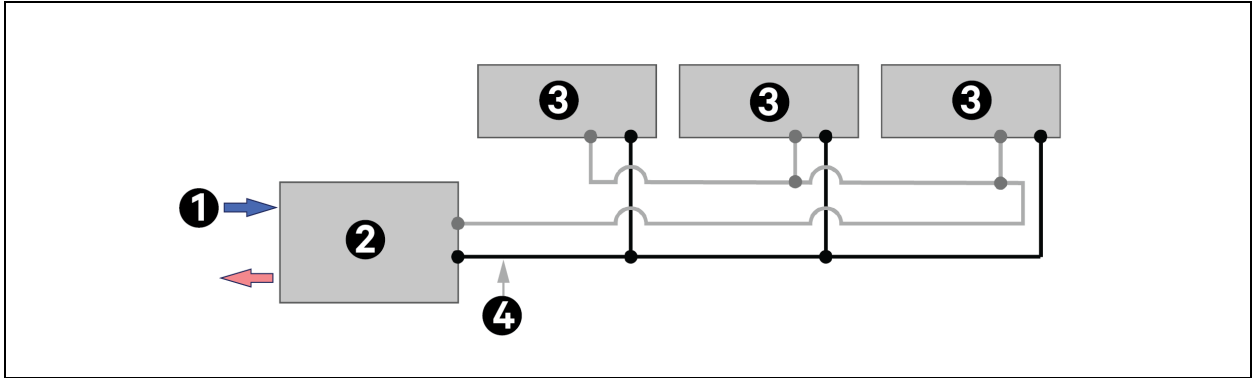

Item	Description
1	Building chilled water
2	Cooling distribution unit
3	Liebert® DCD
4	Thermal expansion (field provided and installed)

However, if it is not possible, connect the Vertiv™ Liebert® DCD units in a non-interlaced configuration as seen in Figure 4.5 below .

Figure 4.5 Non-interlaced Piping

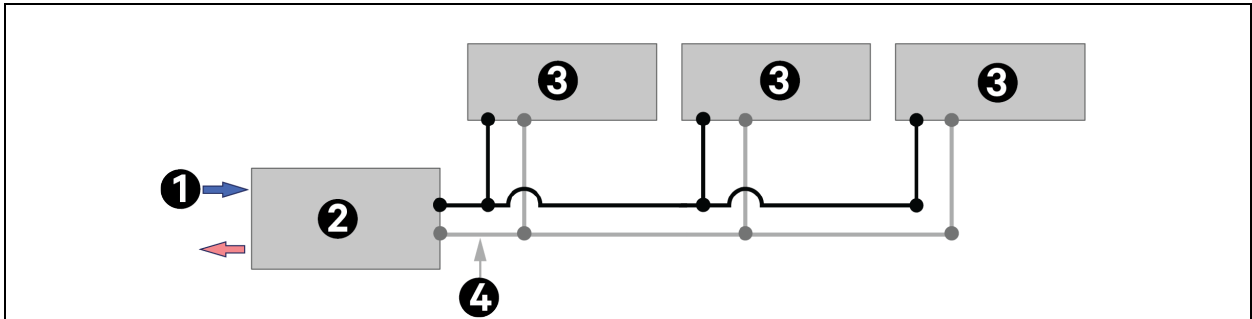

Item	Description
1	Building chilled water
2	Cooling distribution unit
3	Liebert® DCD
4	Thermal expansion (field provided and installed)

It is recommended to add a connecting set. It consists of a ball valve and a commissioning valve to each unit (supply and return pipe). It allows the unit to be disconnected from the system for repairs and maintenance without taking the whole system down and enables the system to be hydraulically balanced.

4.3.1 Using Chilled Water Distribution Units (CDU)

Using a chilled water distribution unit provides these benefits:

- Isolates the building's chilled water circuit from the chilled water circuit within the data center. The Coolant Distribution Unit circulates the chilled water to the Vertiv™ Liebert® DCD while preventing condensation by maintaining the water temperature above the room dew point. Per local code, a fluid thermal expansion tank must be installed.
- Ensures that the proper flow rate to the Liebert® DCD, a critical factor in achieving and maintaining the needed capacity.
- Separating the data center from the building chilled water circuit also minimizes the impact of a leak within the data center. If a leak occurs, the volume of water is limited to the amount within secondary piping system instead of the entire building chilled water system.

4.3.2 Using Open Loop Chilled Water Systems

Maintaining the proper chilled water flow rate is critical in achieving the design capacity of the Liebert® DCD. If you are not using a chilled water distribution unit, you must take steps to ensure the proper flow at the unit is maintained. You should incorporate an expansion tank or another method into the design to account for fluid expansion. See the **Table 10.1** on page 56 in Appendix A for water quality requirements for open loop systems.

Table 4.2 Minimum Chilled Water Temperature

Minimum chilled water supply temperature according to maximum relative humidity and minimum room temperature [°C]									
	Minimum room temperature [°C]								
Relative humidity	10	12	14	16	18	20	22	24	26
40%	2**	2**	2*	3*	5	7	9	10	12
50%	2**	3*	5	7	8	10	12	14	16
60%	4	5	7	9	11	13	15	17	19
70%	6	8	10	12	13	15	17	19	21
80%	8	10	12	14	15	17	19	21	23
90%	9	11	13	15	17	19	21	23	25
100%	11	13	15	17	19	21	23	25	27

* Mind anti-freeze

** Mind anti-freeze, risk of icing at lower temperatures

Table 4.3 Minimum Chilled Water Temperature

Minimum chilled water supply temperature according to maximum relative humidity and minimum room temperature [°F]							
Relative humidity	Minimum room temperature [°F]						
	50	55	60	65	70	75	80
40%	35**	35**	38*	42	47	51	56
50%	35**	39*	43	48	53	57	62
60%	39	43	48	53	58	62	67
70%	43	47	52	57	62	67	71
80%	46	51	56	61	66	70	75
90%	49	54	59	64	69	74	79
100%	52	57	62	67	72	77	82

* Mind anti-freeze

** Mind anti-freeze, risk of icing at lower temperatures

4.3.3 Floor Cut Out for Units with Bottom Connections

Figure 4.6 Floor Cut Outs Below the Unit Itself

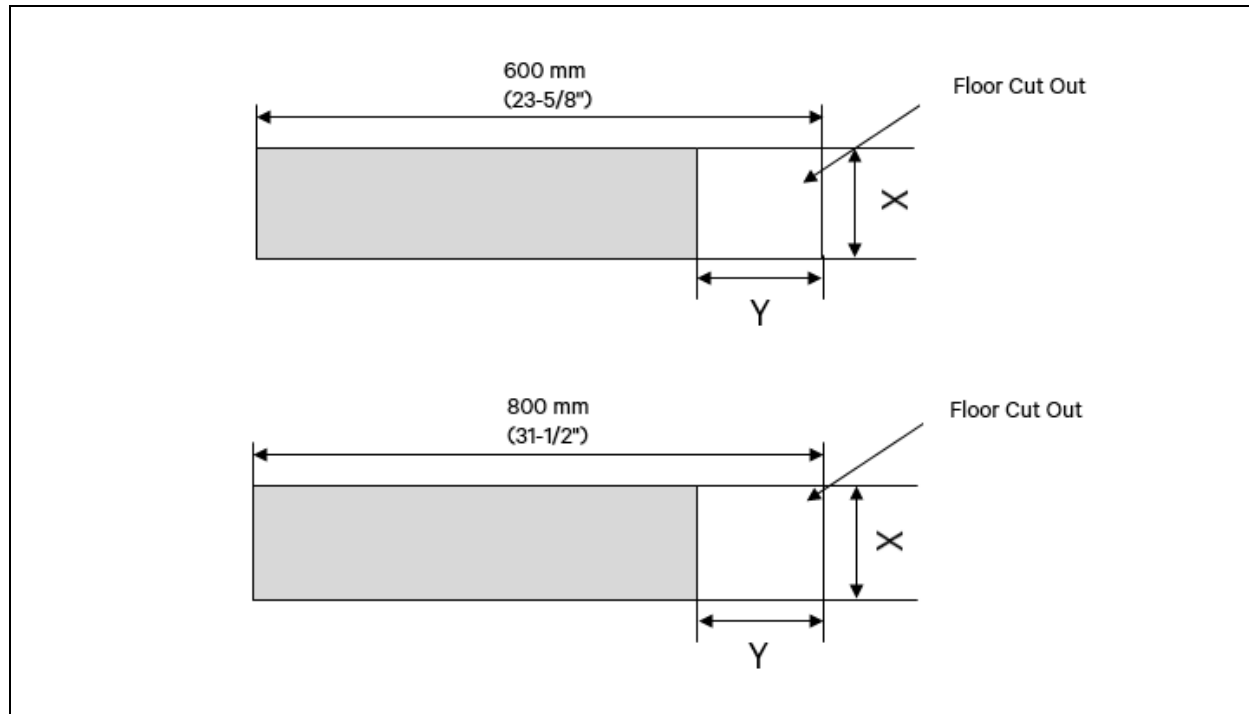

Model	X mm (Inch)	Y mm (Inch)
Vertiv™ Liebert® DCD35/50	120 (4.72)	54 (2.12)
Vertiv™ Liebert® DCD47	185 (7.28)	74 (2.91)

NOTE: Vertiv™ Liebert® DCD50 is for width 800 mm only. For details, see [Unit Code](#) on page 3 .

Figure 4.7 Floor Cut Outs-Unit with Aluminum Frame for 3rd Party Racks

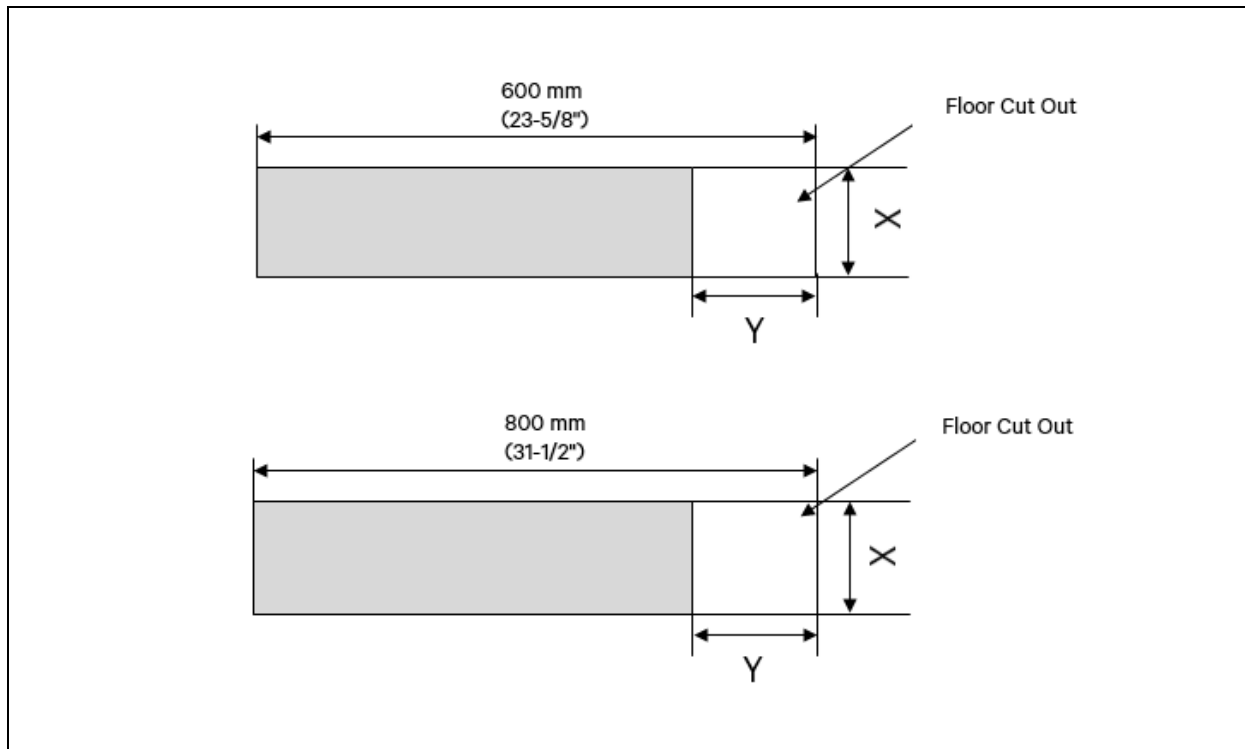

Model	X mm (Inch)	Y mm (Inch)
Vertiv™ Liebert® DCD35/50	186 (7.32)	54 (2.12)
Vertiv™ Liebert® DCD47	251 (9.88)	74 (2.91)

NOTE: Vertiv™ Liebert® DCD50 is for width 800 mm only. For details, see [Unit Code](#) on page 3 .

4.4 Assembly Procedure and Tools Required

NOTICE

Assembly of the Vertiv™ Liebert® DCD must be carried out in vertical position of the device. Please use a level to make sure this requirement is met when commencing the installation. Liebert® DCD and the rack must be vertically aligned to provide proper functionality. Strict separation between the hot and cold air within the cabinet must exist.

NOTICE

To ensure sufficient air circulation please make sure there are no obstructions (such as packaging materials, tools) left in

- Grids
- Heat exchanger
- Air intake
- Air outlet

This guideline only applies if you have bought Vertiv™ Liebert® DCD as a separate product (not being part of a rack already). If you bought the Liebert® DCD as a part of the rack it would come already assembled. In this case please proceed (after unpacking – **Figure 4.8** on the facing page) to attaching the hose adaptor piece from beneath (**Figure 4.14** on page 22). The procedure described is valid for Vertiv™ Liebert® Cabinet (DCM) only.

 **WARNING! Protective equipment (such as boots) must be worn during installation and maintenance of this device. Please check your local regulations on using safety equipment before commencing any operations. This procedure also requires at least 2 people to complete. The Vertiv™ Liebert® DCD35 weights 73 kg (approximately 160 pounds), Vertiv™ Liebert® DCD47 weights 106 kg (approximately 233 pounds). Vertiv™ Liebert® DCD50 weights 93 kg (approximately 205 pounds).**

 **CAUTION: Installation and commissioning of the Vertiv™ Liebert® DCD must be performed only by qualified personnel. All actions must be in accordance with regulations and instructions of the manufacturer.**

NOTE: For the installation, two or more operators are required.

Table 4.4 List of Tools Required



Tool Description	Symbol
Socket hexagonal screw driver - 8 mm (5/16") (for M5 screws)	
Open – jaw wrench 41 mm (1-5/8")	
Open – jaw wrench 36 mm (1-7/16")	
Phillips screw driver PH3	
Utility knife	
Forklift, pallet jack (or similar device)	

Table 4.5 Packaging List (Vertiv™ Liebert® DCD35/47/50)

Quantity	Component Description	
2	ST Mounting bracket for cabinet	Individual components
2	ST Cover swivel-joint fixed component	
2	ST Cover swivel-joint door component	
1	ST Foam UL94-HF1 20 mmx32 mm	
1	ST Condensate drain-set	
<hr/>		
1	ST Wire - grounding 250/6 RA5xRA5	Bag no. 1
1	ST Earth wire 200/6 RA5xFH6,3pl	
7	ST M5 Tensilock nut	
6	ST M5 mounting nut-MIR.extrusion	
8	ST Washer M5	

Table 4.5 Packaging List (Vertiv™ Liebert® DCD35/47/50) (continued)

Quantity	Component Description	
30	ST Star screw M5x10	Bag no. 2
16	ST Spring nut M5 broad	Bag no. 3
8	ST DIN965 M6x16	Bag no. 4

To unpack Vertiv™ Liebert® DCD (shipped separately) follow the instructions shown in **Figure 4.8** below .

Figure 4.8 Unpacking Liebert® DCD

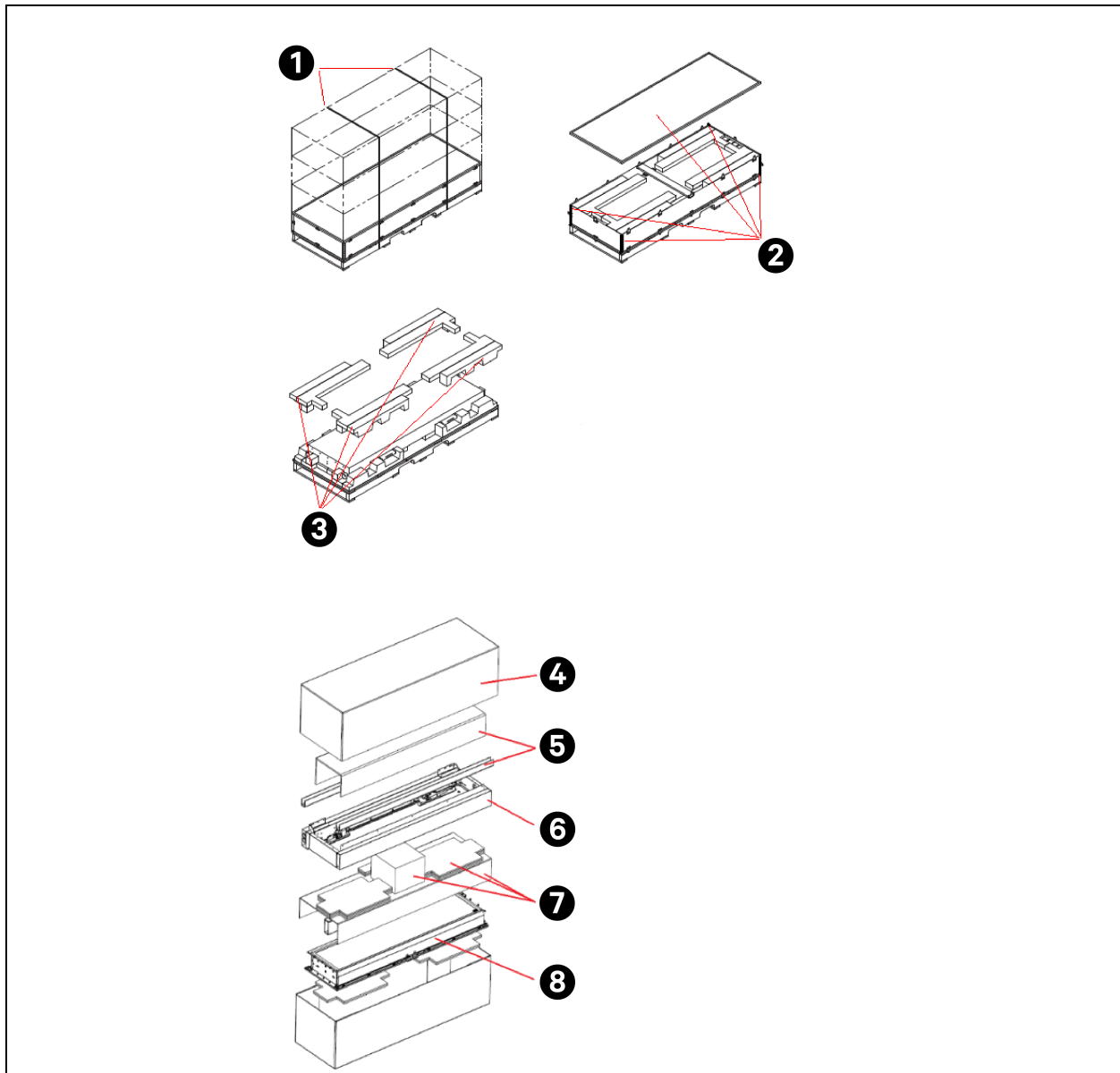

1. Cut binding straps.
2. Remove the cover and the corner pieces.
3. Remove the protective foam pieces.
4. Remove the upper part of the slip lid box.
5. Remove the cover and the U-profiles (protective frame).
6. Remove the Vertiv™ Liebert® DCD frame.
7. Remove the accessories and the cover with all insoles.
8. Remove the Liebert® DCD.

To unpack the Liebert® DCD assembled to a cabinet follow instructions shown in **Figure 4.8** on the previous page and **Figure 4.9** below .

Figure 4.9 Unpacking the Liebert® DCD (Part of the Rack)

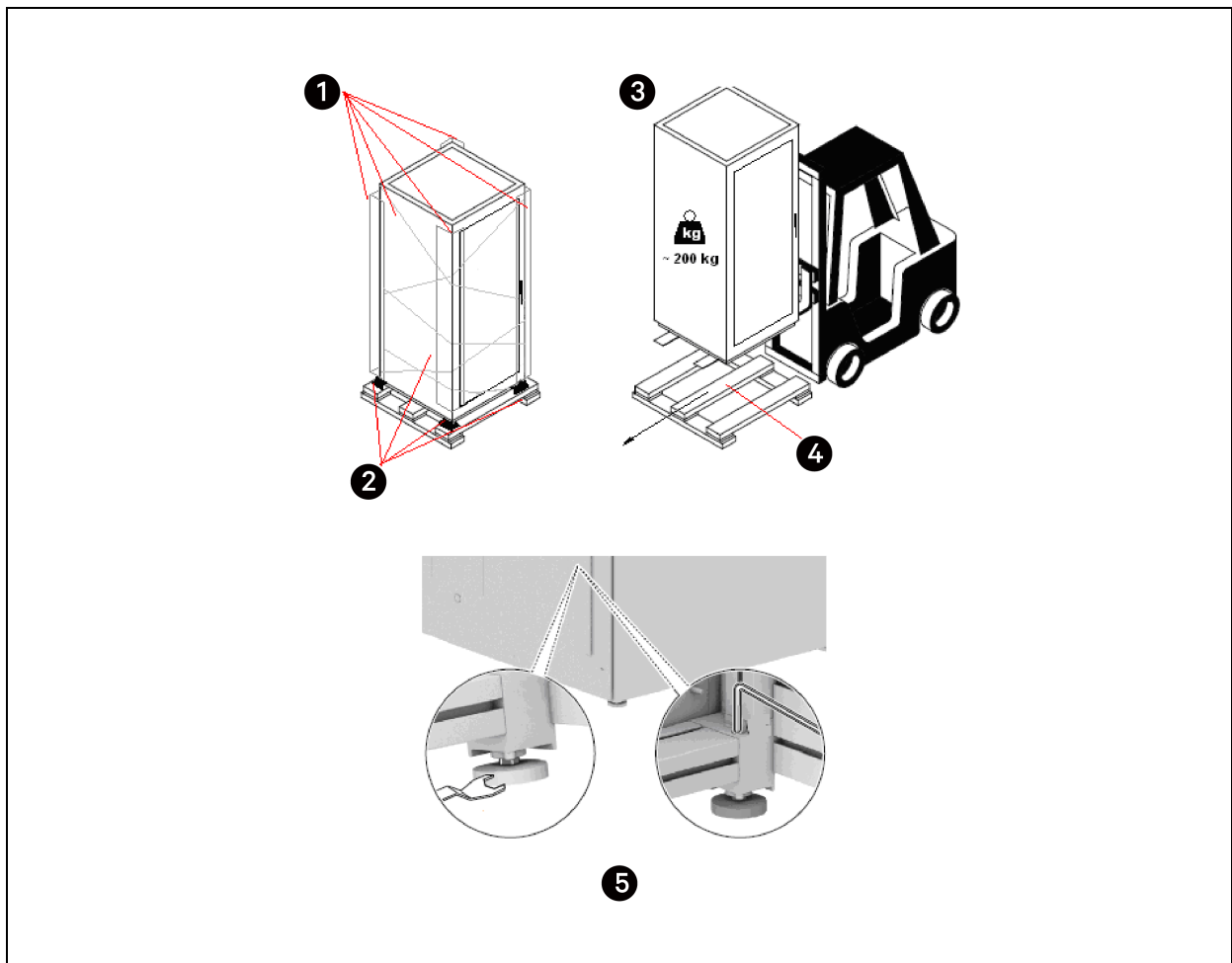

1. Remove the shrink wrap and the corner protectors.
2. Unscrew the braces (4 pieces).
3. Lift the unit off the pallet with the forklift.
4. Slide the pallet out.
5. Adjust the feet.

1. After removing the packaging, first lift the Vertiv™ Liebert® DCD frame off the pallet (**Figure 4.10** below). At this point the door and the frame are not fixed together yet.

Figure 4.10 Lifting the Frame



2. Align the frame of the Liebert® DCD to server rack properly. Mark the positions of the frame holes (there are 16 holes) on the aluminum profile of the server rack and put the frame aside again (**Figure 4.11** below).

Figure 4.11 Marking the Position

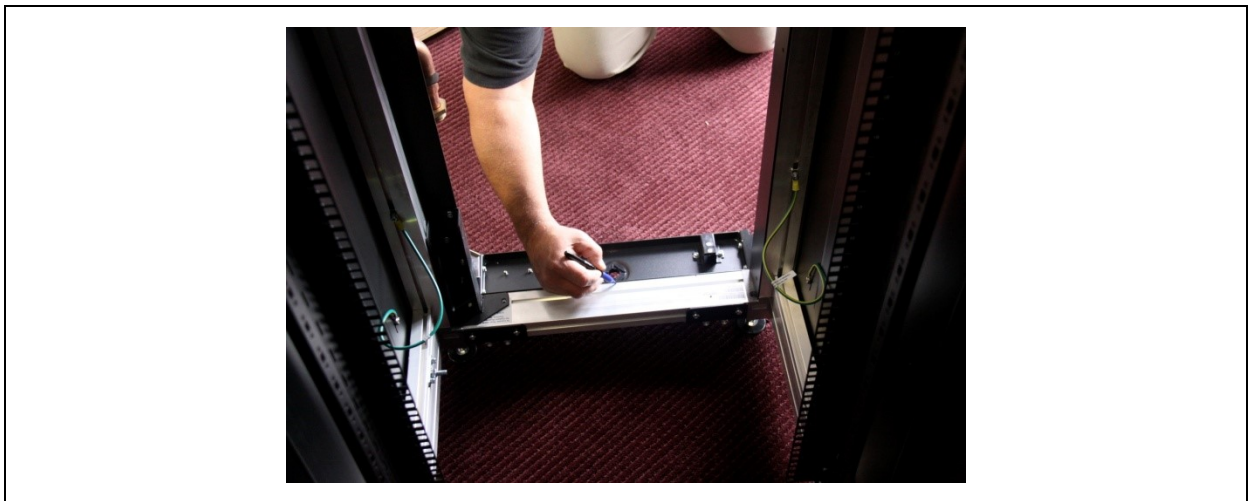

3. After that, insert the spring nuts into the groove of the vertical rack aluminum profile in to previously marked position (Figure 4.12 below).

Figure 4.12 Inserting the Spring Nuts

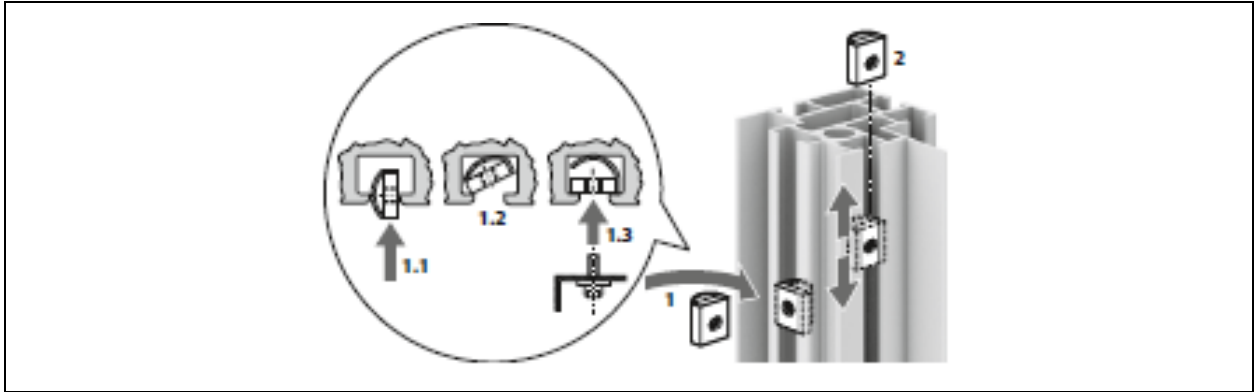

4. Insert 3 diamond nuts into the grove of each horizontal member of the rack aluminum profile in the previously marked position (Figure 4.13 below). Horizontal members are the top and bottom sections of the rack aluminum profile.

Figure 4.13 Diamond Nuts

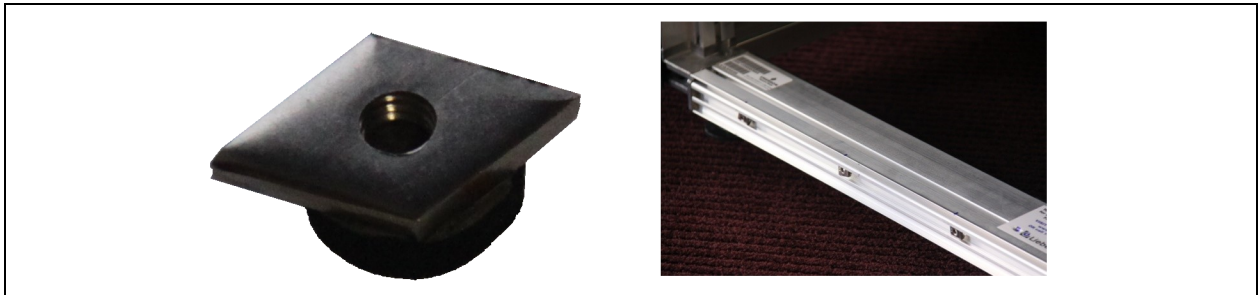

5. Before proceeding to the next step, connect the hose adaptor piece (5/8 ") into the condensate tray (remove the white plastic plug first) (Figure 4.14 below).

Figure 4.14 Hose Piece Adaptor



- In the next step, place the adhesive strip of foam (included) on the rack's aluminum profile (hinge side) in such way that when the Vertiv™ Liebert® DCD frame is in the position the foam strip will seal the gap between rack and the Liebert® DCD frame (It might be necessary to trim the foam strip with utility knife) (Figure 4.15 below).

Figure 4.15 Position of the Sealing Foam

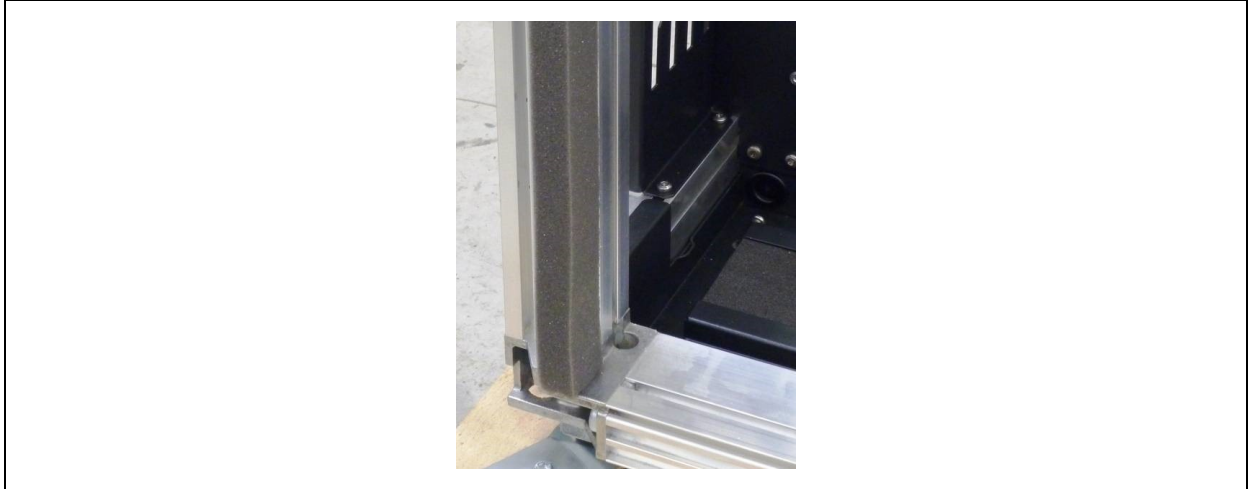

- Now you can start attaching the frame of Liebert® DCD to the rack using the socket screw driver (Figure 4.16 below). Tighten the screws all around the perimeter of the frame, first lightly and then to **3 Nm** (2 foot/pound). This is the only way to prevent the frame from twisting and to ensure the parts fit properly.

Figure 4.16 Tightening the Screws



Make sure there is no twist in the frame before proceeding. The next step in installation is to attach the heat exchanger door to the frame.



WARNING! Risk of injury. The heat exchanger door is very heavy (73 kg, approximately 160 pounds for Vertiv™ Liebert® DCD35/106 kg, approximately 233 pounds for Vertiv™ Liebert® DCD 47/93 kg, approximately 205 pounds for Vertiv™ Liebert® DCD50). At least 2 people are required to install with the door.

- Carefully align the door to the frame and insert the door into the frame (**Figure 4.17** below).

Figure 4.17 Installing the Door



- Hinges are already attached to the door. Fasten them to the frame of the Vertiv™ Liebert® DCD using the Phillips screw driver (**Figure 4.17** above). Then check if the door moves freely all the way. If you notice any irregularities or roughness in the movement of the door, check for obstructions or loosen the screws of the hinges and tighten them again. (The rough movement might have occurred because of the twist in the hinges).
- Pull the flexible piping slightly to elongate. This allows the piping enough length to connect the union nuts.

Figure 4.18 Flexible Piping

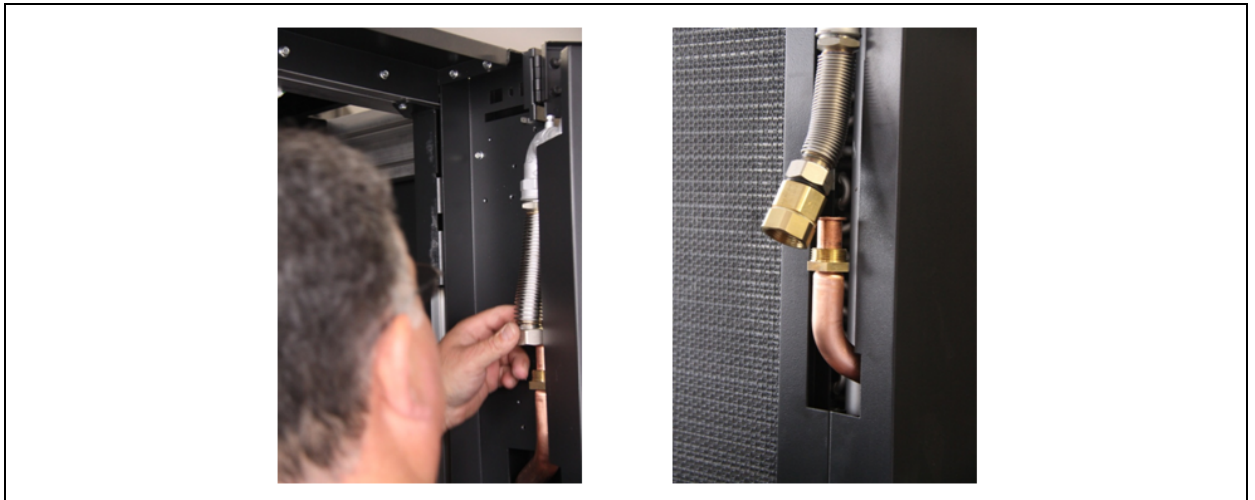

11. Before connecting the heat exchanger (in the door) with the pipe work in the frame of the Vertiv™ Liebert® DCD, put sealing rings in this connection (**Figure 4.19** below). Use two wrenches when tightening the union nuts to reduce the stress on the pipes (**Figure 4.21** on the next page). Torque value for this connection is **85 Nm** (64 foot/pound).

Figure 4.19 Inserting Sealing Rings

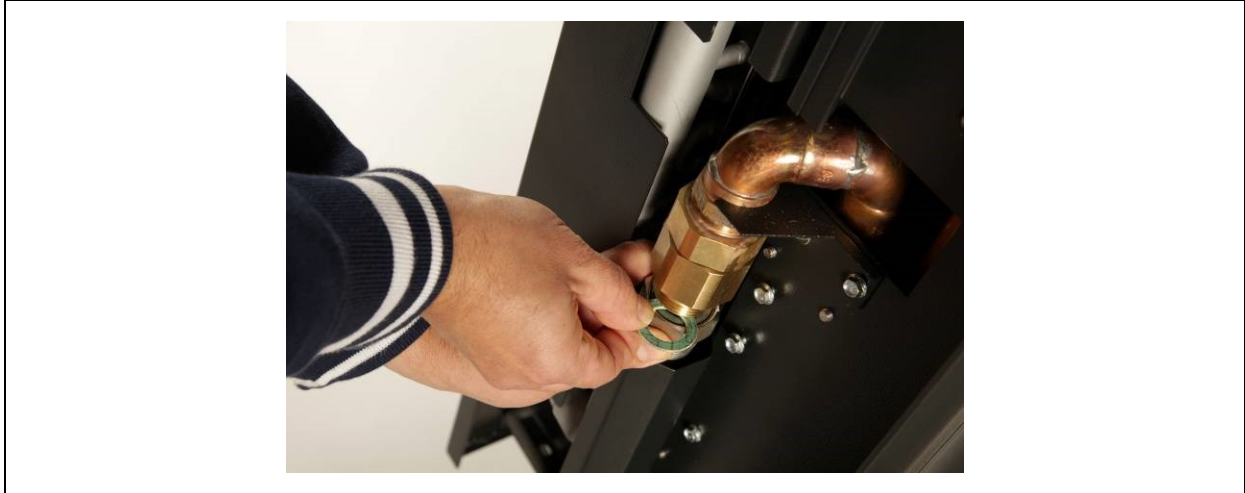

Figure 4.20 Piping Connection

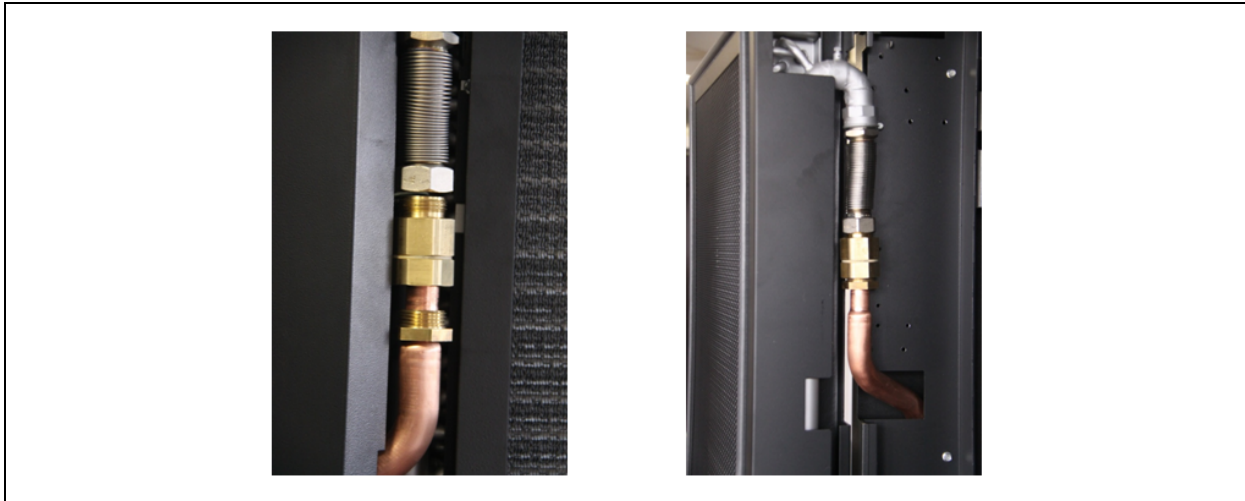
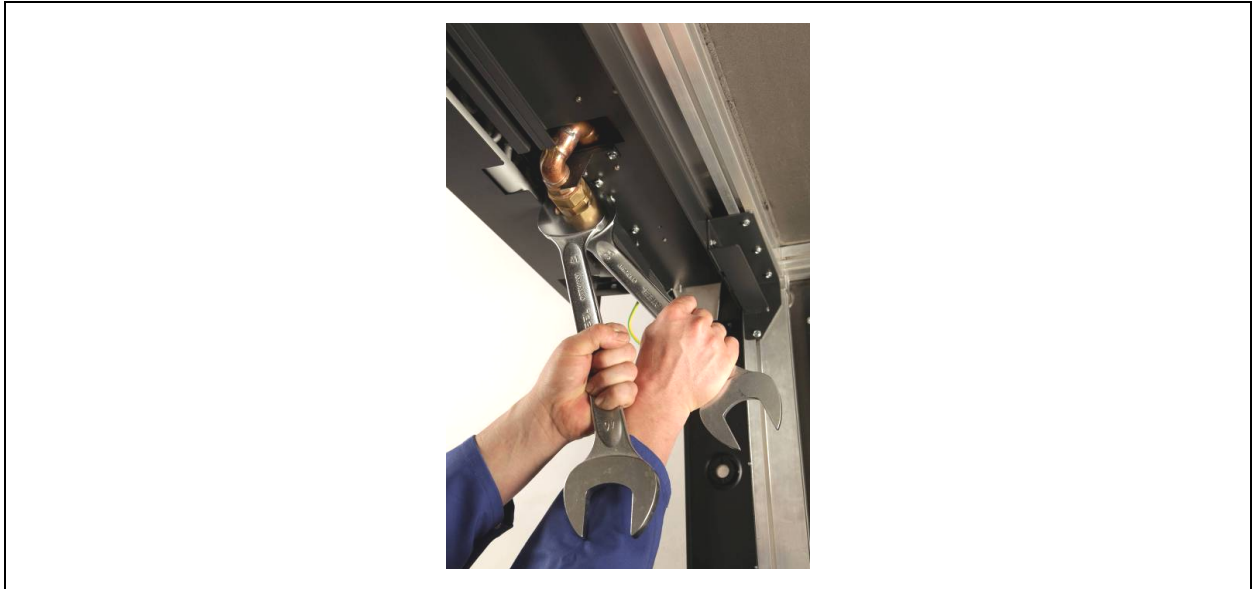
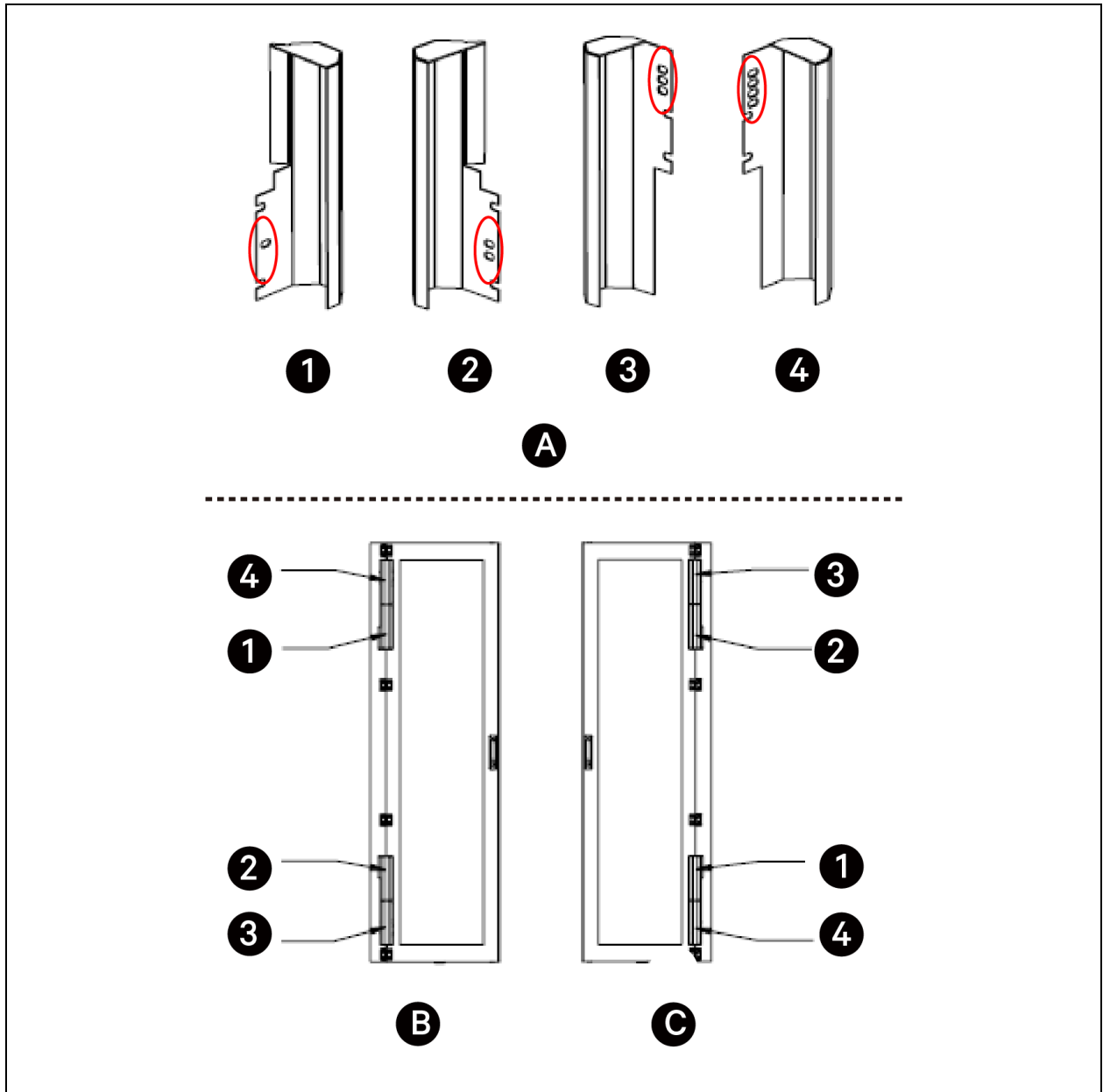

Figure 4.21 Tightening the Union Nuts



12. Check again if the door is moving freely at this point. If so, you can attach the swivel joint covers.
13. The two-outmost swivel joint covers are to be attached to the hinge side of the door. The two inside swivel joint covers are to be attached to the hinge side of the frame (**Figure 4.22** on the facing page). Use hexagonal screw driver to fasten the screws. Correct orientation of the hinge covers is indicated by slotted holes.

Figure 4.22 Hinge Covers Orientation and Position



Item	Description
A	Number of slotted holes
B	Left hand side hinges
C	Right hand side hinges
1	One slotted holes
2	Two slotted holes
3	Three slotted holes
4	Four slotted holes

Figure 4.23 Outmost Swivel Joint Covers Connection Points

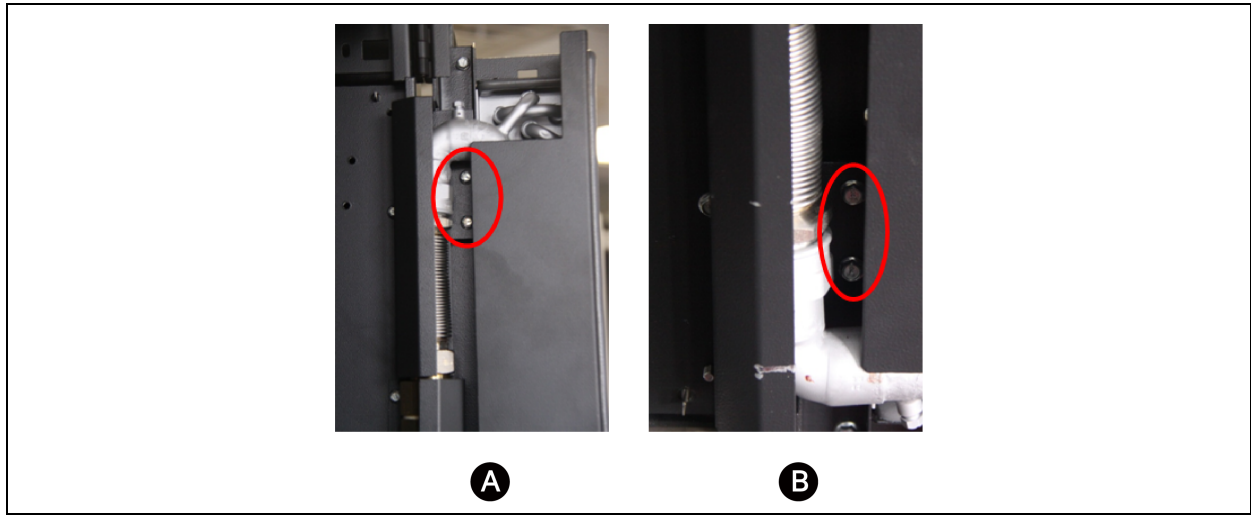

Item	Description
A	Top swivel joint
B	Bottom swivel joint

Figure 4.24 Attaching the Swivel Joint Covers

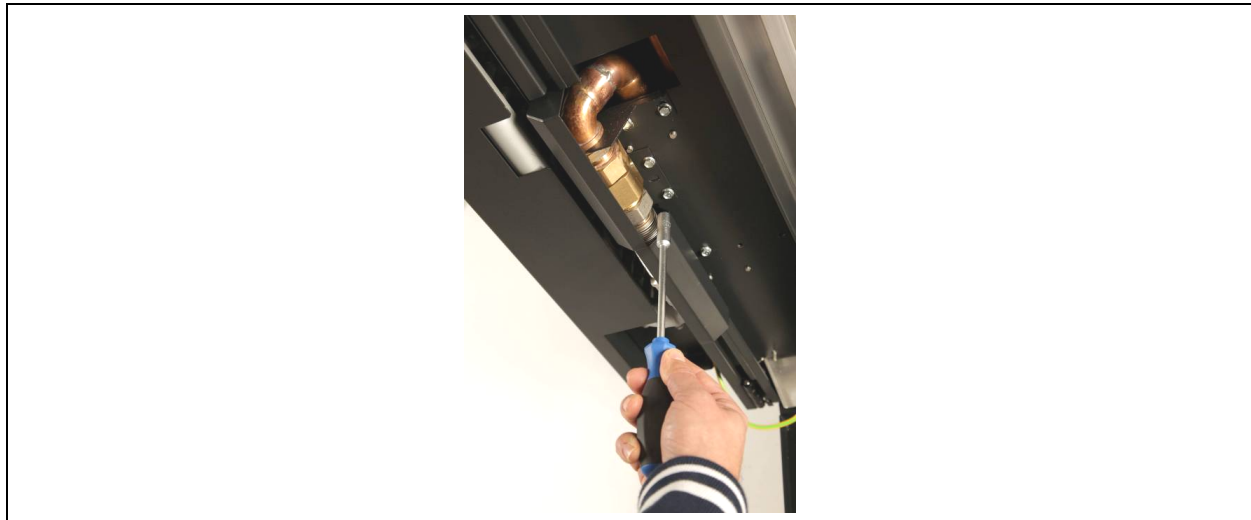

14. Locate the inside swivel joint cover connection points. The two inside swivel joint covers are to be attached to the hinge side of the frame. Correct orientation of the hinge covers is indicated by a sticker on the covers themselves. Use hexagonal screw driver to fasten the screws.

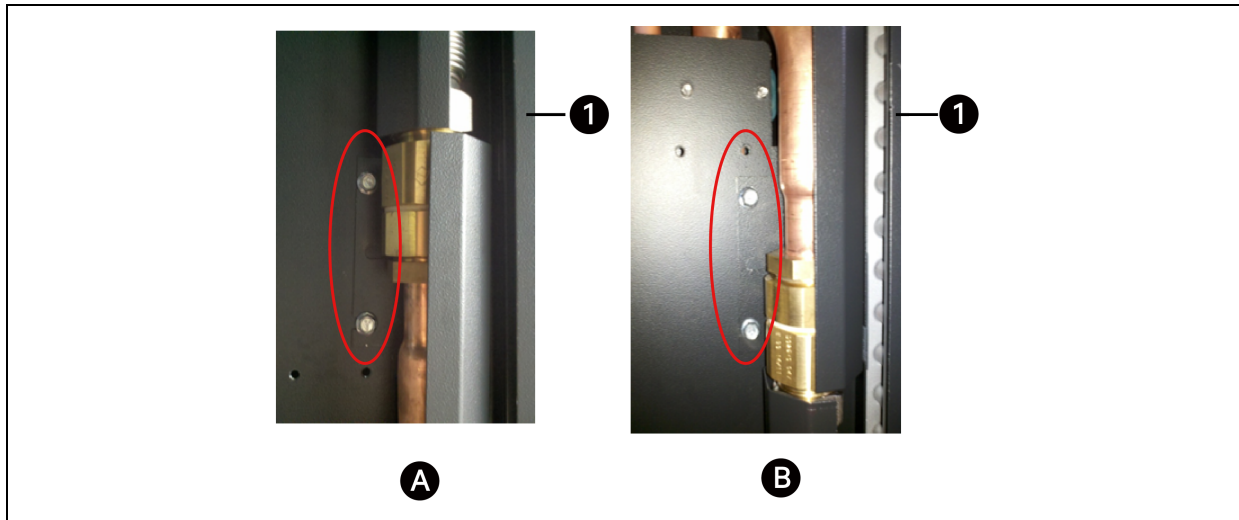

Item	Description
A	Top swivel joint
B	Bottom swivel joint
1	Door

15. In the last step, connect the grounding wire of the door to the frame of the Vertiv™ Liebert® DCD (Figure 4.25 below).

Figure 4.25 Attaching the Grounding Wire



Check if this connection is alright (such as by using diode or continuity test on an electrical meter).

16. Check functionality of the door lock. Liebert® DCD is equipped with DIRAK 1333 lock. It is a half cylinder lock. Keys are provided.

4.5 Insulate Piping

Insulate all piping for the Vertiv™ Liebert® DCD to minimize the possibility of condensation.

4.6 Recommended Pipe Sizes

Elbows and restrictions should be minimized to establish sufficient fluid flow.

Table 4.6 Recommended Pipe Sizes

Piping Run	Nominal Pipe Size (Inch)
Supply or Return mains	2-5/8 NOTE: When using the Liebert® DCD with a Coolant Distribution Unit, refer to the pipe sizes in the Coolant Distribution Unit Installer/User Guide.
Supply or Return branches >10 ft	1-3/8
Supply or Return branches <10 ft	1-1/8

4.7 Chilled Water Connection

NOTICE

Check the chilled water system for leaks visually before commissioning. Please check the chilled water pipe connection to the heat exchanger regularly. Tighten this connection if necessary. When setting up the heat exchanger for the first time please inspect the mechanical condition of the chilled water supply and connection thoroughly.

NOTE: Using the optional connection set (Vertiv™ Liebert® DCDactive Fan Module on page 39) improves the ventilation and enables chilled water flow monitoring and regulation.



CAUTION: There is a risk of frost damage to the device during longer stops (the unit must be drained if supplemental cooling is not required for longer periods of time). Make sure the heat exchanger and the supply pipes are free of any water (use compressed air if necessary) and remove all the vents and the screws before storing.



CAUTION: The coil and piping can be damaged due to thermal expansion of the cooling fluid with no means of expansion. (When closing the ball valves on both the supply and the return pipes). Always allow for thermal expansion either by leaving at least one of the valves open or by opening the bleeding valve on the door.

Supply and return pipes are marked by label on the unit itself. Torque value for this connection is **85 Nm (64 foot/pound)**.

Figure 4.26 Pipe Labels Position

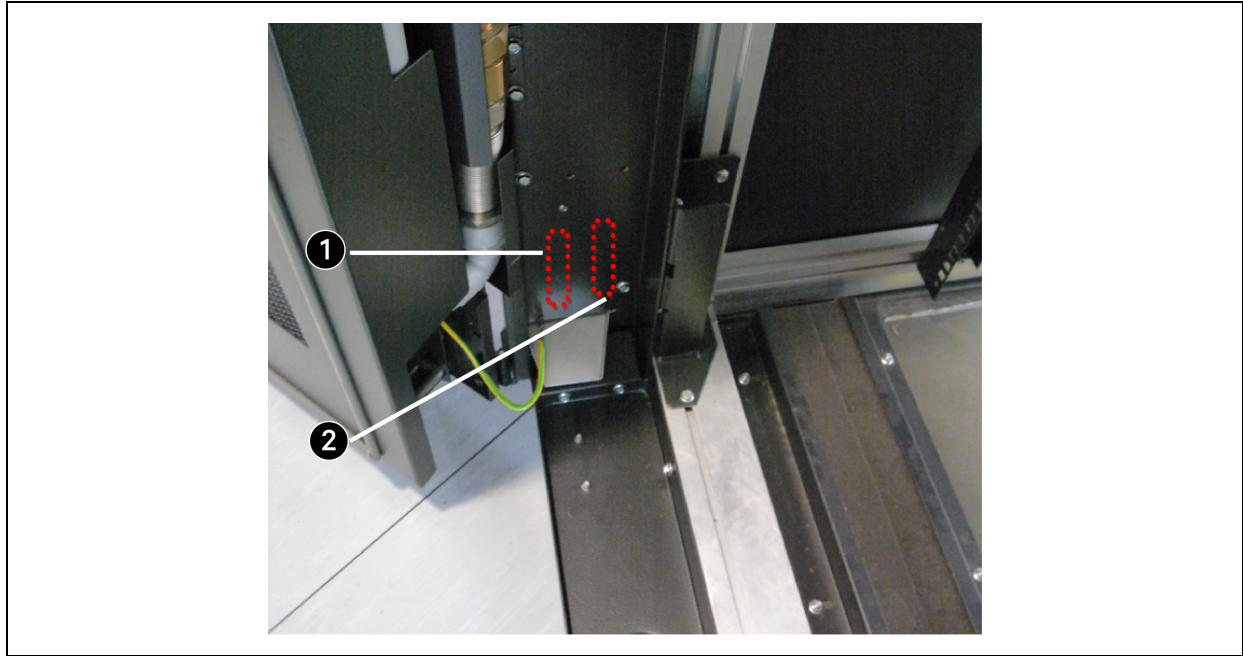

Item	Description
1	Pipe A label (always towards the hinges)
2	Pipe B label (always towards the rack)

Table 4.7 Pipe Positioning

Hinge Side	Chilled Water Connection	Supply Connection	Return Connection
Left	Top	B	A
Left	Bottom	A	B
Right	Top	A	B
Right	Bottom	B	A

Figure 4.27 Chilled Water Connection

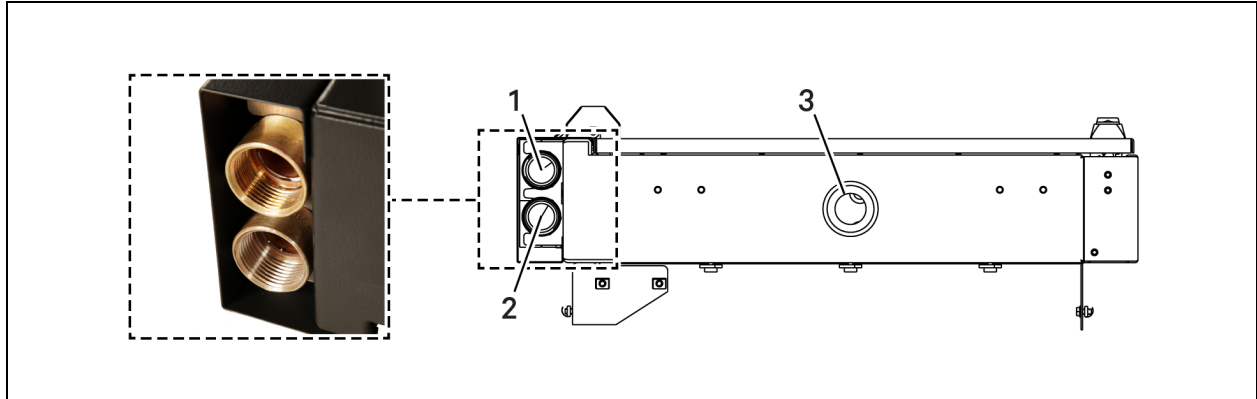

Item	Description
1	Chilled water outlet (bottom view)
2	Chilled water inlet (bottom view)
3	Condensate drain port

NOTE: For water supply from the bottom left or top right of the position, the supply water connection is the outward pipe. The return water connection is then the position towards the rack.

With water connection from top left or bottom right, the water supply connection is the pipe towards the rack. The return pipe then has the position toward the outside.

4.7.1 Strainer

Install a 20-40 mesh strainer on the chilled water supply to the Coolant Distribution Unit. The strainer is required to prevent particles in the chilled water from entering the DCP’s heat exchanger. The strainer must be no more than 10 ft (3 m) from the Coolant Distribution Unit.

4.7.2 Service Valves

Install 1 in. ball valves (field supplied/field installed on the supply and return lines to the Vertiv™ Liebert® DCD to allow service on the unit without shutting down the entire system.

4.7.3 Balancing Valves

Install balancing valves (circuit setters in the supply line to the unit). Refer to **Figure 10.1** on page 61, **Figure 10.7** on page 64 and **Figure 10.13** on page 67, for the proper flow rate required to achieve the site specific capacity.

4.7.4 Flexible Pipes

Liebert® DCD Flex Pipe kits are available in 1500 mm (59 ft.) nominal lengths. The kit consists of two hoses, manual commissioning valve, and shut off valve. See [Connection Set Liebert® DCD](#) on page 41 for more information about these kits.

Figure 4.28 Acceptable and Unacceptable Pipe Bend Radius

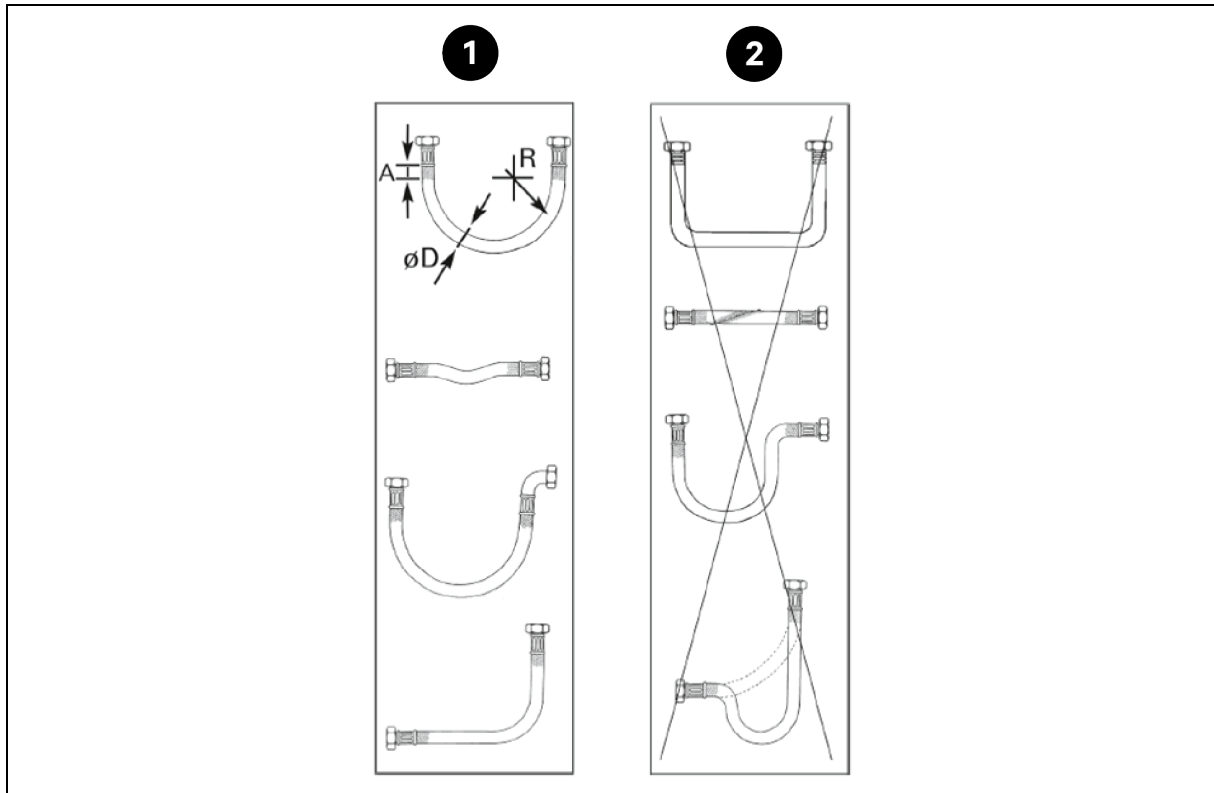

Item	Description
1	Acceptable radii
2	Unacceptable radii

Figure 4.29 Pipe Dimensions

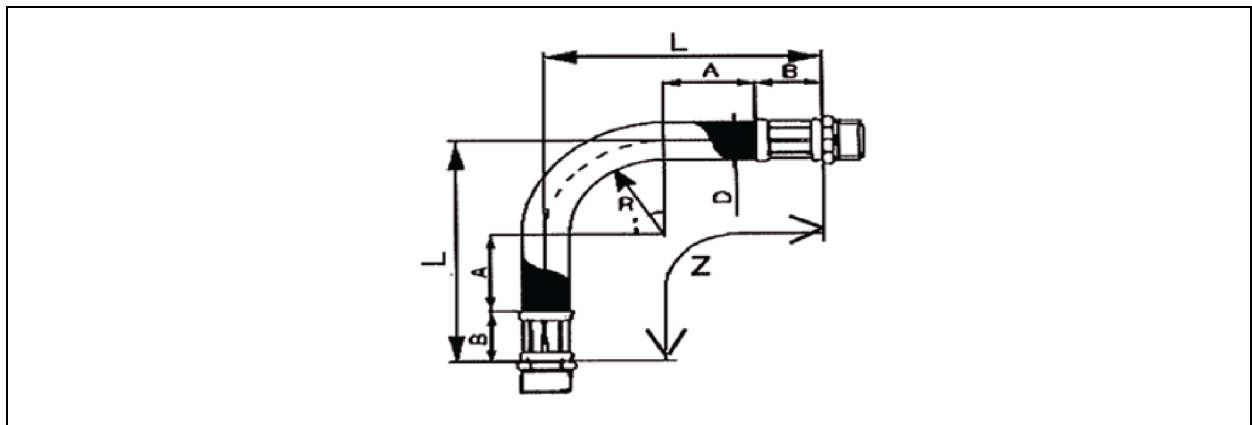

DN	inch	D	R	A	B	L	Z 90°	Z 180°
25	1	33	99	110	34	260	470	652
32	1 1/4	42	126	130	55	332	600	830

4.8 Leak Checking

NOTICE

Risk of leaking water. Can cause equipment damage and serious building damage.

Check the chilled water system for leaks before commissioning. Check the chilled water pipe connection to the heat exchanger regularly. Tighten this connection if necessary.

When setting up the heat exchanger for the first time, inspect the mechanical condition of the chilled water supply and connection thoroughly.

1. Confirm that the flow directions of field installed components are correct.
2. Confirm that all isolating valves are open.
3. Test the water quality when filling the system, see [Quality Requirements for Water Used in the Vertiv™ Liebert® DCD](#) on page 56 .
4. Set the pressure at 145 psi (10 bars) maximum for at least 30 minutes or according to local codes.
5. Repair any leaks.

4.9 Filling the Unit

If using a Coolant Distribution Unit, refer to its user manual for instructions on filling the Vertiv™ Liebert® DCD and starting the system.

4.9.1 Bleeding Air from the Liebert® DCD

The Liebert® DCD has two Schrader valves, one at the top and one at the bottom. The two valves provide flexibility for bottom or top chilled water connections. Air trapped in the unit or piping must be bled from the valve at the top. Opening the lower valve releases water.

NOTICE

Risk of water release. Can cause equipment and building damage.

The Schrader valve at the top of the Liebert® DCD must be used when bleeding air from the unit. Opening the lower Schrader valve will release water.

- a. Find the Schrader valve at the top of the Liebert® DCD, see **Figure 4.30** on the facing page .
- b. Depress the pin to open the valve.
- c. Keep the Schrader valve open until the water coming out has no bubbles.

NOTE: When using a top connection, the commissioning valve in the hose kit is an additional bleed point. Use a bleeding apparatus to prevent water from spilling (available as a ship-loose item).

Figure 4.30 Schrader Valve to Bleed Air from Unit



4.10 Housing Integrity

To provide optimal cooling function following requirements must be met:

- Strict separation between the hot and cold air must exist within the rack.
- All the inlets (such as cable lines, piping) must be sealed to prevent any leakages.

4.11 Application Conditions

NOTE: Appropriate use. The device is a rear door heat exchanger for a server cabinet with integrated chilled water piping. The server fans themselves remove the heat from the racks to protect the temperature sensitive components in the rack. The waste heat from inside of the rack is transferred via the chilled water circuit to the outside and passed to the on site chilled water system.

NOTE: For reliable function of the Vertiv™ Liebert® DCD, chilled water must be available in an appropriate amount, at the appropriate temperature and pressure. The water quality must be in accordance with VGB-R 455 P. Refer the **Table 10.1** on page 56 and **Table 10.2** on page 56 in Appendix A for more detail.

Table 4.8 Technical Specifications

Parameter	Value
Cooling Air	
Housing material	Steel plate (powder coated)
Operating ambient temperature	10 °C - 35 °C (50 °F - 95 °F) (other temperatures on request)
Maximum absolute air humidity on site*	8 g kg-1 (10.5 °C / 61 °F)
Air outlet temperature	18 °C - 27 °C (64.4 °F - 80.6 °F) (in accordance with ASHARE)
Air temperature difference IN - OUT	15 K - 20 K
Chilled Water	
Cooling performance	

Table 4.8 Technical Specifications (continued)

Parameter	Value
Liebert® DCD35	35 kW
Liebert® DCD47	47 kW
Liebert® DCD50	50 kW
Chilled water temperature inlet	12 °C – 18 °C (53.6 °F – 64.4 °F) (other temperatures on request)
Chilled water temperature outlet	18 °C – 24 °C (64.4 °F – 75.2 °F) (other temperatures on request)
Water temperature difference	6 K, 10.8 °F (other temperatures on request)
Maximum operating pressure	10 bar (145 psi)
Pipe Connection IN / OUT	
Liebert® DCD35/50	1" female threaded (BSP Rp 1")
Liebert® DCD47	1 1/4" female threaded (BSP Rp 1 1/4")
Maximum chilled water flow rate Liebert® DCD35	1.5 l/s (5.4 m³/h, 23.8 gal/min)
Maximum chilled water flow rate Liebert® DCD47/DCD50	2.0 l/s (7.2 m³/h, 31.7 gal/min)
Condensate tray drain connection	Rack–rear side
Use of Propylene/Ethylene Glycol solution	Not recommended (available on request)
*See the Table 4.2 on page 15 and Table 4.3 on page 16 for more details.	

Table 4.9 Operation Conditions

Parameter	Value
Operating ambient temperature	10 °C – 35 °C (other temperatures on request) 50 °F – 95 °F
Maximum absolute air humidity on site	8 g·kg ⁻¹ (10.5 °C / 61 °F)
Chilled water temperature intake	12 °C, 53.6 °F (other temperatures on request)
Chilled water temperature outlet	18 °C, 64.4 °F (other temperatures on request)
Water temperature difference	6 K, 10.8 °F (other temperatures on request)
Use of antifreeze	Not recommended (on request)
Chilled water connection	Rack– rear side (top or bottom connection) 1" female threaded (BSP Rp 1")
Condensate tray drain connection	Rack–rear side
Maximum operating pressure	10 bar (145 psi)
Maximum chilled water flow rate Liebert® DCD 35	1.5 l/s (5.4 m³/h, 23.8 gal/min)
Maximum chilled water flow rate Liebert® DCD 50 and Liebert® DCD47	2.0 l/s (7.2 m³/h, 31.7 gal/min)

NOTE: The chilled water supply temperature should be higher than the dew point temperature of the installation space. Vertiv™ Liebert® DCD is designed only for sensible cooling; dehumidification of the room by means of Liebert® DCD should be avoided. The built in condensate tray with condensate drain is designed only for a short term condensation.

5 Description

5.1 General Function

The design of Vertiv™ Liebert® DCD allows installation in the back of a server cabinet. Heat produced by internal components (such as servers) is reliably removed by the door with built-in chilled water system. The cooling system is completely safe so that no water can get into the server area. The cooling system consists of a high efficiency air-water heat exchanger. By operating as a rear door heat exchanger with an appropriate design (see [Quality Requirements for Water Used in the Vertiv™ Liebert® DCD](#) on page 56) no heat (thermal load) in the surrounding area is given.



CAUTION: The cooling with Liebert® DCD works only if a strict air separation exists between server cold air intake and server warm air outlet. Unused rack spaces must be sealed with empty plates.

Figure 5.1 Top View of the Rack Equipped with Liebert® DCD

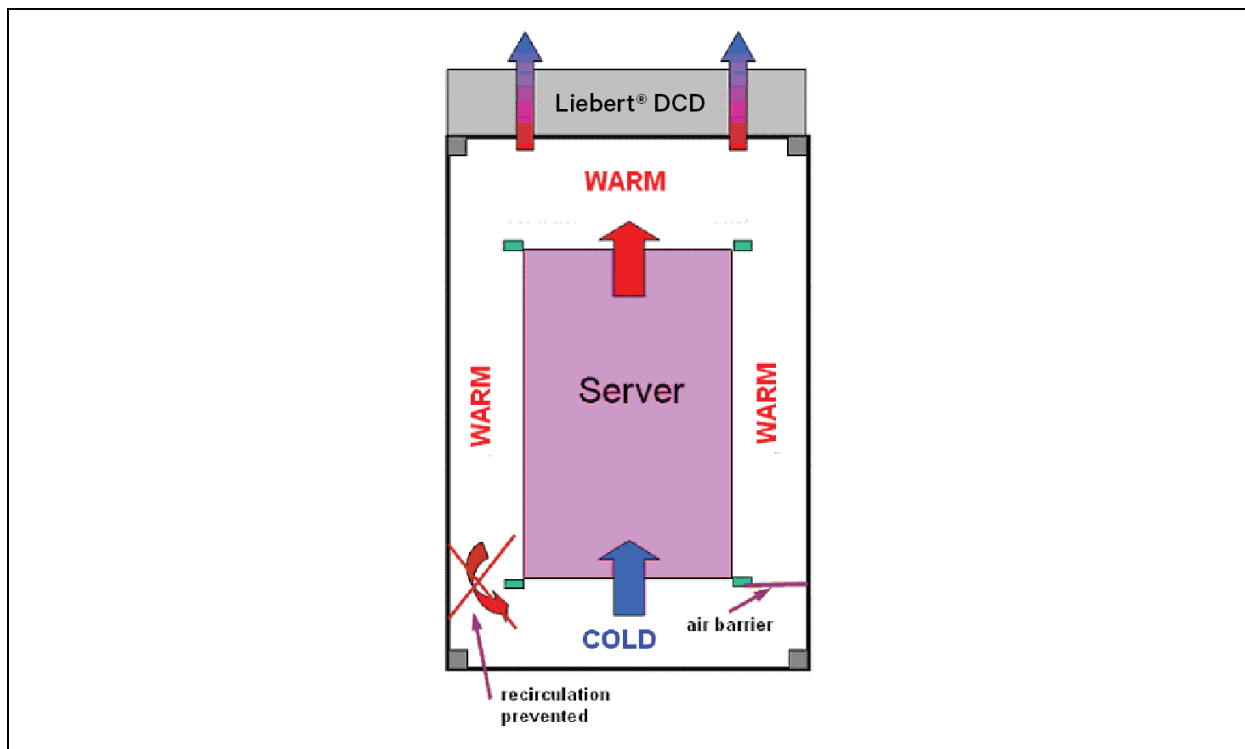

5.2 Cooling Principle

Figure 5.2 Rack Equipped with Vertiv™ Liebert® DCD (Side View)

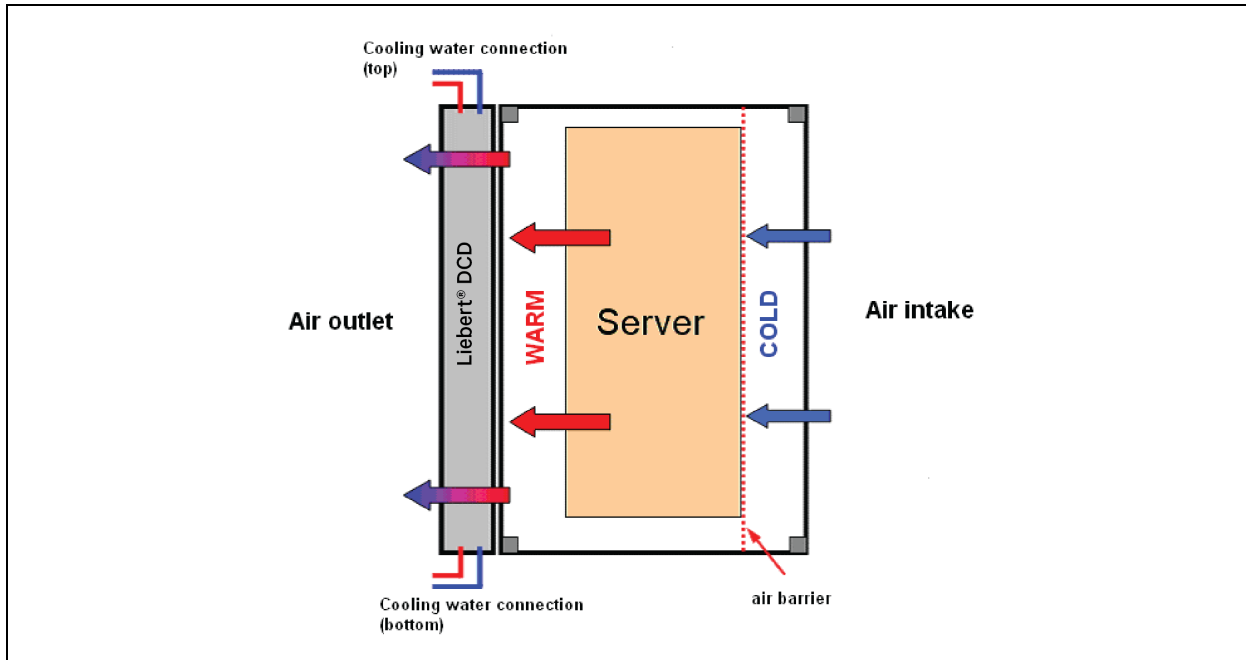

Air heated by the server 40 °C (104 °F), is forced through the special air – water heat exchanger. In the heat exchanger the air is cooled down to 20 °C to 25 °C (68 °F to 77 °F). The server fans force the cooling air through the heat exchanger of Liebert® DCD. The pressure drop-flow rate dependency curve is shown in the [Quality Requirements for Water Used in the Vertiv™ Liebert® DCD](#) on page 56 .

NOTE: Prior to using Liebert® DCD the system and the servers must be checked whether they match hydraulically. In particular, the server fans must be able to generate sufficient pressure to drive the air through the Liebert® DCD.

The chilled water is provided by chilled water onsite distribution.

NOTE: In case of chilled water supply system failure, the cooling is provided either by adjacent Liebert® DCDs and/or the installation room cooling system. In this case, the server waste heat is released into the installation room.

6 Variants and Options

6.1 Vertiv™ Liebert® DCD Assembled to Vertiv™ Liebert® DCM Server Rack

Liebert® DCD is typically delivered as a part of a specially prepared server rack. The Liebert® DCM server rack offers guaranteed air separation between the hot and the cold air within the cabinet.

Refer to the Liebert® DCM PN 01.147.992.9

Figure 6.1 Server Rack with the Liebert® DCD



6.2 Vertiv™ Liebert® DCDActive Fan Module

For the operation of a passive Liebert® DCD without fans, the hydraulic impulse of the cooling air of the server fans is used to overcome the flow resistance of the heat exchanger of the Liebert® DCD. As the heat dissipation increases, the air flow rate of the cooling air also increases, resulting in increased hydraulic resistance of the cooling air as it flows through the heat exchanger. The Liebert® DCDActive fan module compensates for this pressure loss. The cooling air volume flow of the Liebert® DCDActive fan module is adapted to the cooling air flow of the servers by means of differential pressure controlled fan speed regulation.

A fan module is available for the Liebert® DCD product series that is mounted on the outside of the Liebert® DCD. For a complete solution consisting of rack, Liebert® DCD and Liebert® DCDActive, the Liebert® DCDActive fan module is already assembled at the factory. However, it can also be retrofitted to the Liebert® DCD. The Liebert® DCDActive is available in two variants, for Liebert® DCD 35 and Liebert® DCD50. For the Liebert® DCD 47, the use of the Liebert® DCD35 fan module is necessary. It is not possible to order a Liebert® DCD47 without the Liebert® DCDActive 35 fan module.

Table 6.1 Usage of Liebert® DCDActive

	Liebert® DCD35 or Liebert® DCD50	Liebert® DCD47
Usage of Liebert® DCDActive	According to pressure difference	Liebert® DCD35 active always required

It is possible to retrofit a fan module to the Liebert® DCD35 and Liebert® DCD50 at a later stage. The installation is simple and can be done by one person within a short time. The Liebert® DCDactive fan module is described in a separate manual. Please see SL-70835 Liebert® DCDactive fan module User Manual.

Figure 6.2 below for Vertiv™ Liebert® DCD35 / Vertiv™ Liebert® DCD50 show the characteristic curves of the system, which describe the relationship between the pressure resistance as a function of the cooling air volume flow. An exact limit value for the differential pressure of the Vertiv™ Liebert® DCD, which describes the necessity of using the Vertiv™ Liebert® DCD Active Module, cannot be defined. This depends on various influencing factors:

- Performance of the fans of the IT equipment installed in the server rack.
- Tightness of the separation of cold and warm air within the installed components.
- Tightness of hot/cold air separation within the server cabinet, especially in the area of the 19" layer and at the 19" mounting spars towards the side wall.
- Air tightness of the server cabinet to the environment, especially in the area of the cable bushings but also at the top and bottom in general.

In some cases, only a test can clarify the matter.

From a differential pressure of about 25 Pa (0.10 inH2O), the use of a Liebert® DCDactive fan module is recommended, above 30 Pa (0.12 inH2O) the use of a passive Liebert® DCD must be confirmed by a test. For some server types with low-performance fans and insufficient internal hot/cold separation, the Liebert® DCDactive may already be required at less than 20 Pa (0.08 inH2O). Using a Liebert® DCDactive fan module does not change heat exchanger performance of the Liebert® DCD. A higher cooling capacity is achieved by an increased volume flow, which is made possible by using the Liebert® DCDactive.

Figure 6.2 Recommended Usage of Liebert® DCDactive

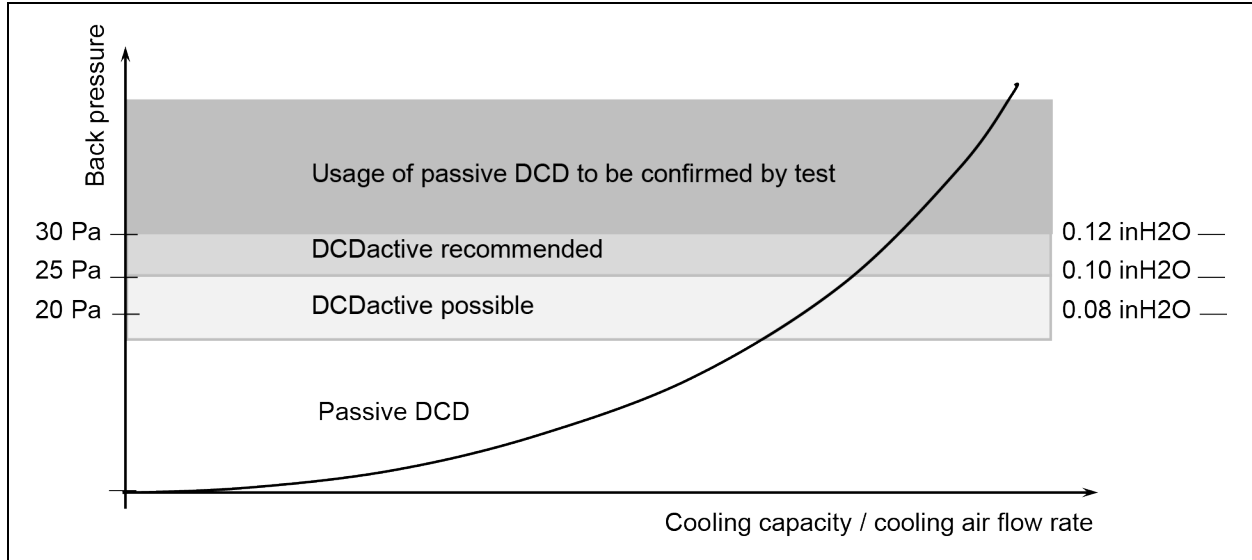

Liebert® DCDactive is offered in different equipment variants, the variants are described under digit 19 in the **Table 2.2** on page 3 of the Liebert® DCD.

Table 6.2 Extract from the Unit Code Table, Selection Liebert® DCDactive Feature

Digit 19	DCDactive Upgrades
N	Standard DCDactive incl. Modbus TCP/IP
T	DCDactive Modbus TCP/IP + monitoring (temp, leakage, door) + display
B	DCDactive with A/B transfer switch 230 VAC incl. Modbus TCP/IP
A	DCDactive with A/B transfer switch 230 VAC + Modbus TCP/IP + monitoring (temp, leakage, door) + display
D	DCDactive with A/B transfer switch 115 VAC incl. Modbus TCP/IP
C	DCDactive with A/B transfer switch 115 VAC + Modbus TCP/IP + monitoring (temp, leakage, door) + display

With the standard configuration, the Vertiv™ Liebert® DCDactive fan module has a:

- Differential pressure controlled fan speed control.
- Two temperature sensors in the area of the fans in the cooled air at the heat exchanger outlet.
- Communication interface with Modbus TCP/IP protocol.
- Failure detection for each fan.
- Common alarm output.

The versions with A/B transfer switch are equipped with a redundant power supply, whereby the Liebert® DCDactive fan module is primarily supplied via the A supply. Only in the event of a failure of the A supply is the power switched to the B supply. As soon as the A supply is available again, it is switched back to A. The switchover takes place without interruption for the operation of the Liebert® DCDactive. There are two versions according to the operating voltage: 120 V and 230 V.

The equipment with additional monitoring (temperature, leakage, and door contact switch) and display contains additional features on top of the standard:

- Four temperature sensors which are preferably placed in the warm air plenum between the air outlet from the server and the air inlet into the Vertiv™ Liebert® DCD.
- A door contact switch for monitoring the door status. This additionally switches off the fans when the door is opened.
- A water detector installed in the leakage and condensate tray to detect water due to leakage or condensation.
- Touch screen with status display, alarm display, also settings for control and alarm management can be modified on the screen.
- Communication interface for water volume flow control with part number 08.009.167.0

The installation of the sensors and the routing of the hose for detecting the static pressure in the warm air plenum for differential pressure control is described in the separate manual for the Liebert® DCDactive fan module 01.998.358.0.

When retrofitting a Liebert® DCD to an existing cabinet, the passive Liebert® DCD and Liebert® DCDactive are supplied separately and must also be ordered separately.

6.3 Connection Set Liebert® DCD

This set is for recommended connection of the Liebert® DCD with the on site chilled water system.

Valid for Liebert® DCD35 and Liebert® DCD50 (Part No. 08.009.066.0), valid for Liebert® DCD47 (Part no. 08.009.091.0).

Liebert® DCD connection set consists of

- **Reinforced hose with nickel - plated connections**
EPDM resistant to water and anti-freeze

Parameter	Value
Temperature range	0 °C + 110 °C (32 °F – 230 °F)
Maximum operating pressure	10 bar (145 psi)
Inner diameter	25 mm (1")
Connection	1" F / 1" M (DIN ISO 228 - 1) Liebert® DCD47: 1 1/4" F / 1 1/4" M (DIN ISO 228-1)
Length	1500 mm (59.1")

(1 mm = 0.0394")

- Ball valve with fitting**
 Ventilation and drain connection 3/4"; possibility of pressure and temperature measurements.
 Connection 1" F (DIN ISO 228 - 1)
- Shut off and regulation valve**
 Discharge vent 3/4"; possibility of pressure and temperature measurements.
 Connection 1" F (DIN ISO 228 - 1)

Figure 6.3 Connection Set

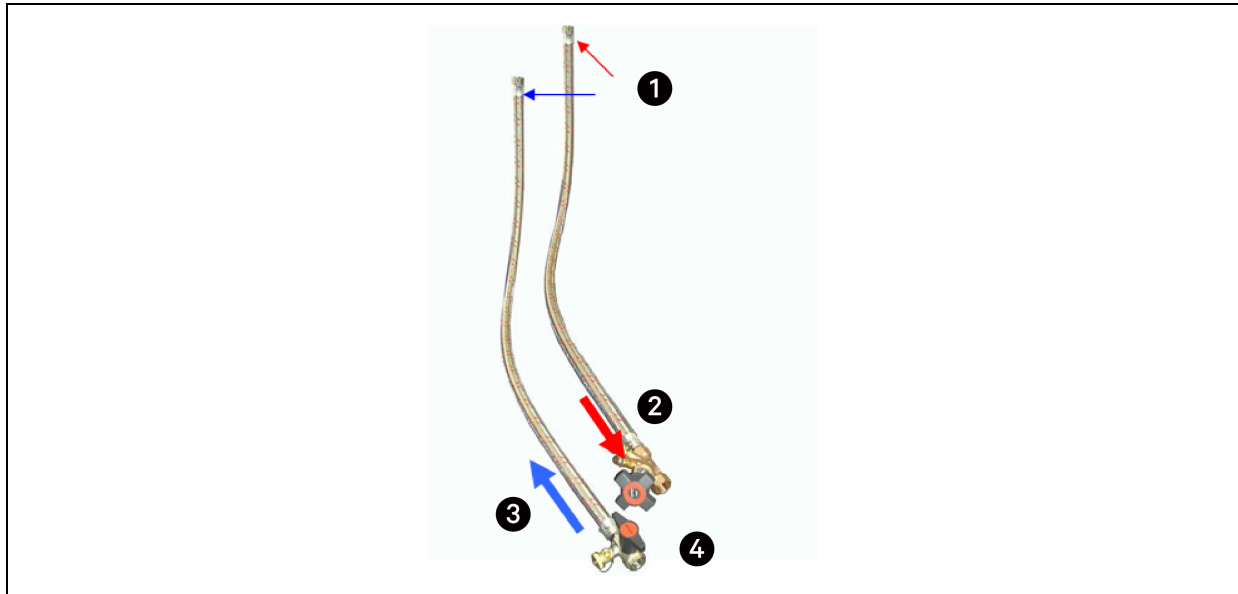

Item	Description
1	Connection to the Vertiv™ Liebert® DCD
2	Chilled water outlet (hot)
3	Chilled water intake (cold)
4	Connection to the on site chilled system

Figure 6.4 Connection Set-Detail

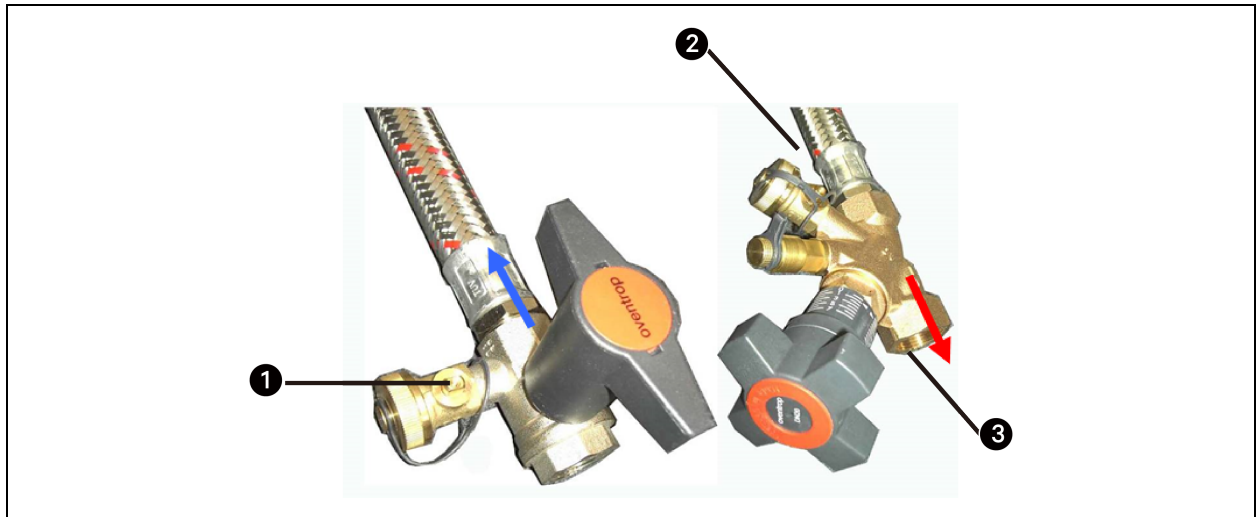

Item	Description
1	Ball valve - 1" connection ventilation and drain connections (pressure and temperature measurements possible)
2	Bleeding and ventilation point (flow rate measurements possible)
3	Shut off and regulation valve (flow rate measurements possible)

NOTE: All parts of the set are supplied as individual parts and are connected by the customer.

Please refer to **Figure 6.5** on the next page and **Figure 6.6** on page 45 for the proper installation of the Vertiv™ Liebert® DCD connection sets for both top and bottom connection to the unit.

Figure 6.5 Supply and Return Hose Kit Bottom Piping Connections (Left Hinge)

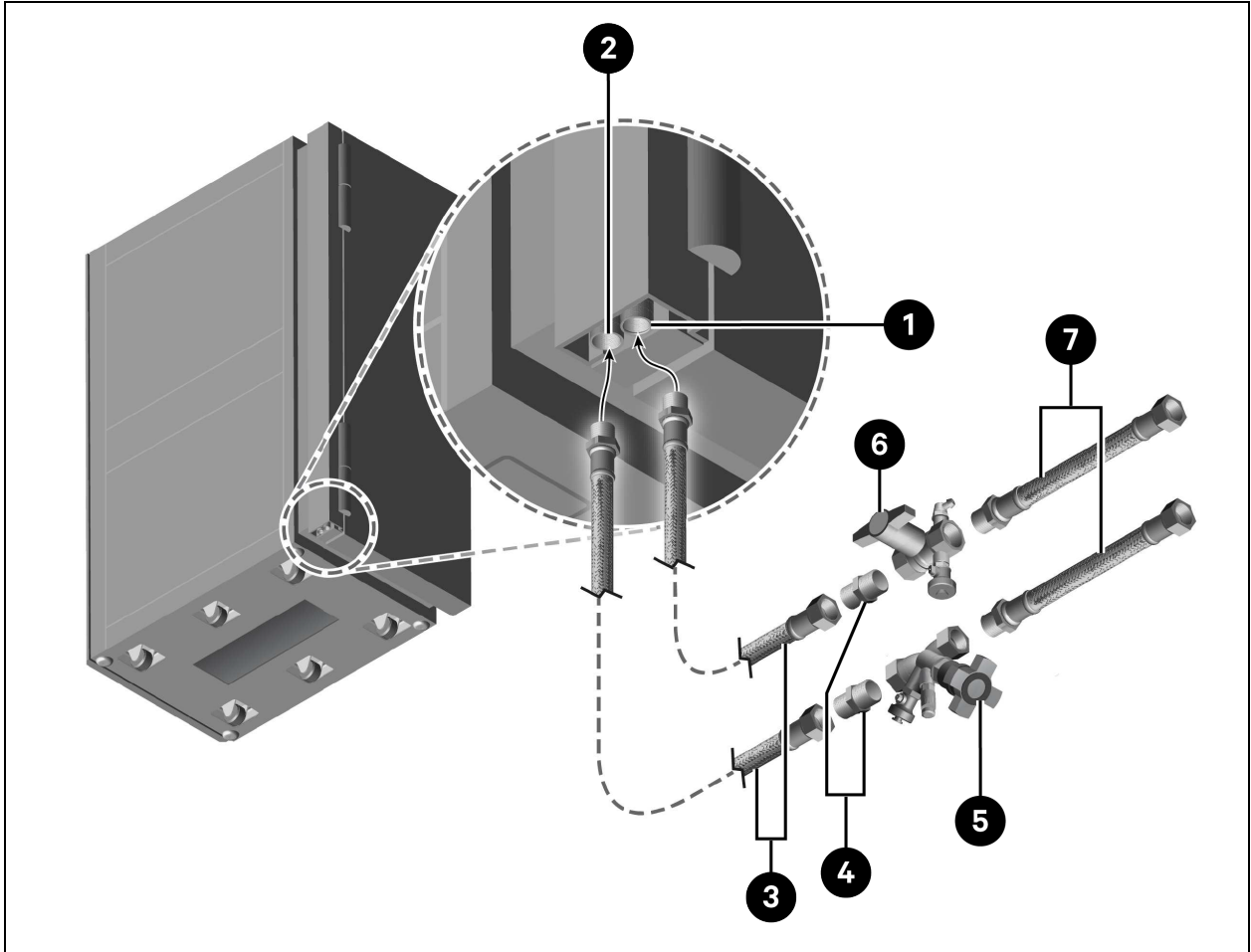

Item	Description
Included in Ship Loose Hose Kit	
1	DCD Supply water connection
2	DCD Return water connection
3	Flex metal hose (available in 1500 mm (59"))
4	Male to male nipple NOTE: Loctite 5776 is required to seal adapter [items 4 and 5, and 4 and 6]
5	Manual valve assembly (return side)
6	Shut off valve assembly (supply side)
Additional Ship Loose Item	
7	BPT to 1" NPT nipple adapter or optional 300 mm (12") hose adapter (connect to field installed supply and return header)

Figure 6.6 Supply and Return Hose Kit Top Piping Connections (Left Hinge)

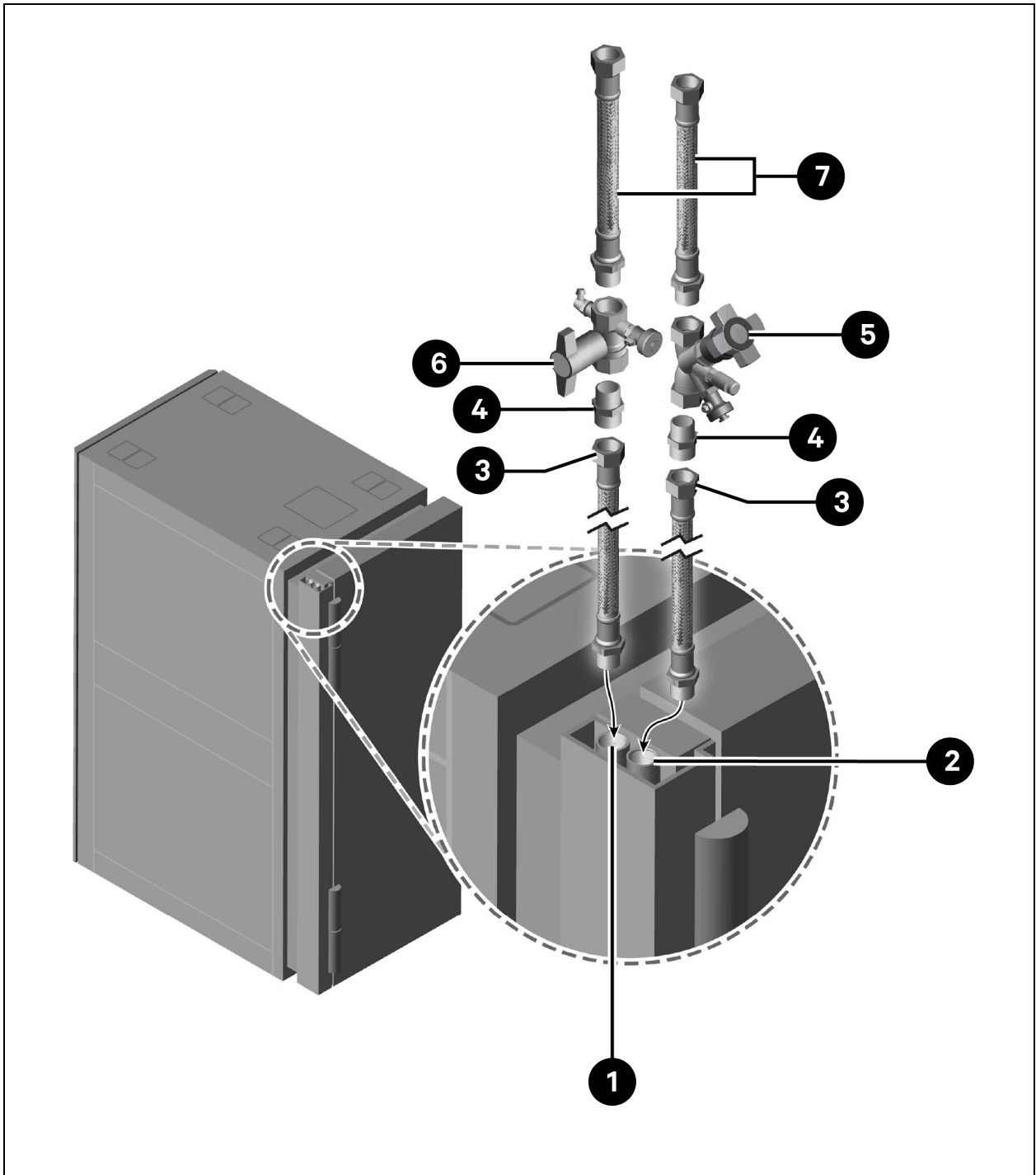

Item	Description
Included in Ship Loose Hose Kit	
1	DCD Supply water connection
2	DCD Return water connection

Item	Description
3	Flex metal hose (Available in 1500 mm (59"))
4	Male to male nipple NOTE: Loctite 5776 is required to seal adapter into [items 4 and 5, and 4 and 6]
5	Manual valve assembly (return side)
6	Shut off valve assembly (supply side)
Additional Ship Loose Item	
7	BPT to 1" NPT nipple adapter or optional 300 mm (12") hose adapter (Connect to field installed supply and return header)

6.4 Spacing Kit and BSP to NPT Adapter

It might be necessary to extend the distance between the supply and the return pipes as well as change the connection thread. For this purpose, it is possible to order the pipe spacing kits. Each kit contains set of 2 hoses (for supply and return). One end of the hose is always fitted with R1" thread for connection to the Vertiv™ Liebert® DCD.

For installation with NPT connections a set of 2 adapter for a connection from 1" BSP female to 1" NPT male can be ordered.

Table 6.3 Spacing Kit and Adapter

Part Number	Description
08.009.160.0	Flexible hose DN25 L300 R1" x Rp1"
08.009.165.0	Adapter BSP 1" female to NPT 1" male
08.009.169.0	Adapter AG BSP 1 1/4" IG NPT 1 1/4"

Figure 6.7 Spacing Kit and Adapter

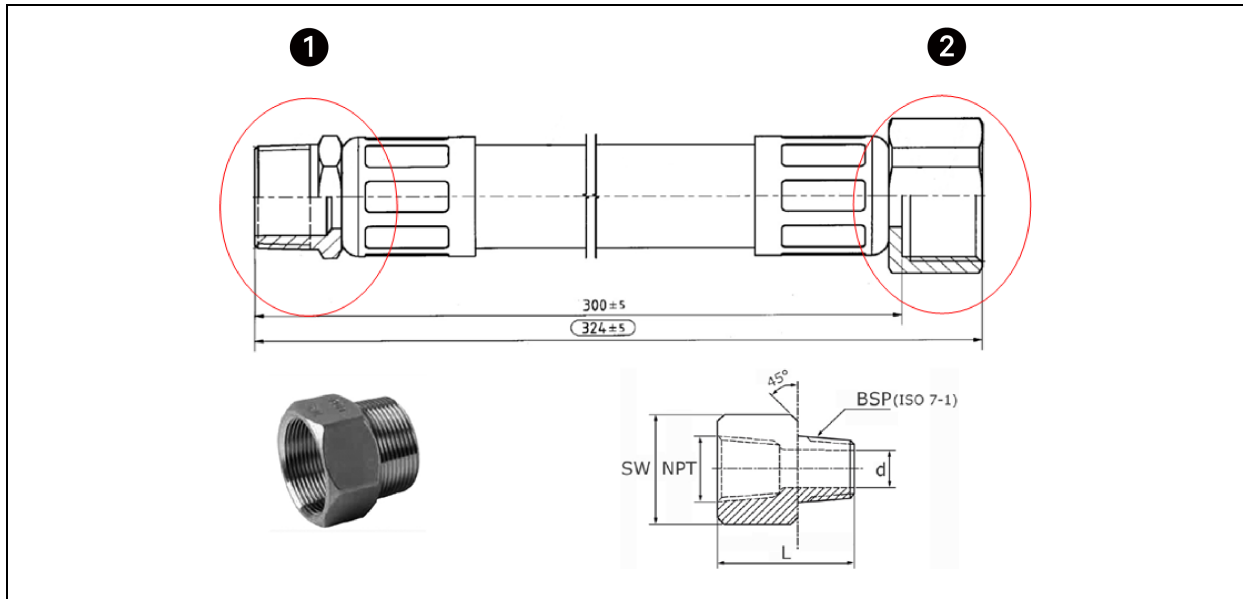

Item	Description
1	To the DCD - R1"
2	To the chilled water network Rp 1"
SW = 38 mm, NPT = 1", BSP = 1", L = 46 mm, d = 26 mm	

This page intentionally left blank

7 Maintenance and Repairs



CAUTION: All maintenance and repair jobs are to be performed by qualified personnel only. All actions must be in accordance with regulations and instructions of the manufacturer.



CAUTION: For maintenance and repair jobs use only the tools and spare parts approved by manufacturer of the device.



CAUTION: Before commencing any work on the chilled water system let the system drain.

NOTICE

General maintenance actions to be carried out:

- Check for heat exchanger pollution (such as dust).
- Check functionality of the valves.
- Check the chilled water system for leaks visually.

NOTE: Dirt such as a dust layer on the heat exchanger reduces the performance of the device and can cause pressure loss or lessened heat transfer a vacuum cleaner, soft brush, or compressed air to clean the fins of the heat exchanger.

This page intentionally left blank

8 Disassembly and Disposal



CAUTION: Disassembly of the Vertiv™ Liebert® DCD may be performed by qualified personnel only.



CAUTION: Shut down the chilled water system before disassembly and prevent it from restarting.

NOTICE

Dispose all the components and parts in accordance with local waste management and regulations. We recommend a recycling company.

All components consist of:

- Aluminum, steel, brass, copper.
- Marked plastic components.

This page intentionally left blank

9 Customer Service

All Vertiv products are subject to continuous quality control and comply with applicable regulations. For any questions you have related to our products, please contact your local Vertiv representative. The details of the country can be found at www.vertiv.com

This page intentionally left blank

Appendices

Appendix A: Technical Support and Contacts

A.1 Technical Support/Service in the United States

Vertiv Group Corporation

24x7 dispatch of technicians for all products.

1-800-543-2378

Liebert® Thermal Management Products

1-800-543-2778

Liebert® Channel Products

1-800-222-5877

Liebert® AC and DC Power Products

1-800-543-2378

A.2 Technical Support/Service in Europe, the Middle East and Africa

Europe, the Middle East and Africa: For technical support, please contact your local Vertiv or Partner office. You can also contact us using the contact details on our website: <https://www.vertiv.com/en-emea/contacts2>

A.3 Locations

United States

Vertiv Headquarters

505 N Cleveland Ave

Westerville, OH, 43082, USA

Europe

Via Leonardo Da Vinci 8 Zona Industriale Tognana

35028 Piove Di Sacco (PD) Italy

Asia

7/F, Dah Sing Financial Centre

3108 Gloucester Road, Wanchai

Hong Kong

Appendix B: Quality Requirements for Water Used in the Vertiv™ Liebert® DCD

In order to safeguard the maximum lifetime of air/water heat exchangers, the water applied for chilling purposes must meet the VGB Chilled Water Guidelines (VGB-R 455 P). The chilled water used must be soft enough to prevent deposits, but it must not be too soft which would lead to corrosion of the heat exchanger.

The **Appendix B:** above contains the most important impurities and counter-measures for their removal:

Table 10.1 Water Quality Requirements

Water Impurity	Method for Removal
Mechanical impurity (dp < 0.3 mm)	Filter the water
Excess hardness	Soften the water by ion exchange
Moderate level of mechanical impurities and hardeners	Add dispersion or stabilizing agents
Moderate level of chemical impurities	Add deadening agents and inhibitors
Biological impurities (bacteria and algae)	Add biocides

It is recommended to get as closest as possible to the following hydrological parameters:

Table 10.2 Hydrological Requirements

Hydrological Data	Values	Units
pH values	(7 - 10,5)	
Carbonate hardness	(3 - 8)	°dH
Free carbon dioxide	(8 - 15)	mg/dm ³
Combined carbon dioxide	(8 - 15)	mg/dm ³
Aggressive carbon dioxide	0	mg/dm ³
Sulphides	< 10	mg/dm ³
Oxygen	< 50	mg/dm ³
Chloride ions	< 250	mg/dm ³
Sulphate ions	< 10	mg/dm ³
Nitrates and nitrites	< 7	mg/dm ³
COB	< 5	mg/dm ³
Ammonia	< 5	mg/dm ³
Iron	< 0.2	mg/dm ³
Manganese	< 0.2	mg/dm ³
Conductivity	< 30	mS/cm
Solid residue from evaporation	< 500	mg/dm ³
Potassium manganese consumption	< 25	mg/dm ³

Table 10.2 Hydrological Requirements (continued)

Hydrological Data	Values	Units
Suspended matter	< 3	mg/dm ³
Partial flow cleaning is recommended	(3 - 15)	mg/dm ³
Permanent cleaning	> 15	mg/dm ³

Appendix C: Checklist for Setting up the Device

Table 10.3 Setup Checklist

Performed Checks	Done (To be signed upon completion)	Remarks
Check device for damage upon receipt.		
Check the ground for being horizontal.		
Check bearing capacity of ground.		
Add-on and align, connect to server cabinet, position feet of the rack and adjust them horizontally		
Cables connected with server cabinet: <ul style="list-style-type: none"> • Temperature sensors (optional) • Server shut-down (optional) • Door contact (optional) 		
Unit connected with set of external valves (optional): <ul style="list-style-type: none"> • Valve drive • Flow meter with temperature sensors (optional) 		
Optional automatic door opening adjusted at server cabinet		
No remainders of packaging inside Vertiv™ Liebert® DCD		
All assembly tools removed		
Bushings into the device proper and air-tight		
Chilled water connection leak-proof / pressure-tested		
Chilled water system is completely bled		
Volume flow of chilled water adjusted		
Condensate water line unobstructed		
Condensate water drain hose trap is in place and functional		
Condensate tray connected to building drain connection		
All front panels closed (air ducts technically separated)		
Expansion Tank		

Place:

Date:

Signature of Engineer:

Appendix D: Functional Check

Mechanical Functions

Damage to heat exchanger

Connections/ fins / surface: none existing

Remarks:

.....

Front door, closing: yes no

Remarks:

.....

Rear door, closing: yes no

Remarks:

.....

Pipe duct inlets / cable bushings closed: yes no

Remarks:

.....

Condensate water drain open / connected: yes no

Remarks:

.....

DCD Active fans operate properly (bearings OK)

Visual check yes no

Remarks:

.....

Appendix E: Thermodynamic Checks

Condensate water forming at heat exchanger yes no

Remarks:

.....

Chilled water entering heat exchanger:°C°F

Chilled water leaving heat exchanger:°C°F

Cabinet temperature in front of heat exchanger:°C°F

Cabinet temperature behind of heat exchanger:°C°F

Chilled water network bled: yes no

Pressure of chilled water network tested: yes no

(customer's protocol available)

Volume flow adjusted: yes no

external

Water flow: l / min external gpm

Remarks:

.....

Correctness of above values is hereby confirmed.

Commissioning was performed during on-going operation.

yes no

.....

Commissioning firm:

Date:

Signature:

Customer:

Date:

Signature:

Appendix F: Performance Charts

F.1 Performance charts for Vertiv™ Liebert® DCD35

Figure 10.1 Performance Chart Liebert® DCD35 – 1

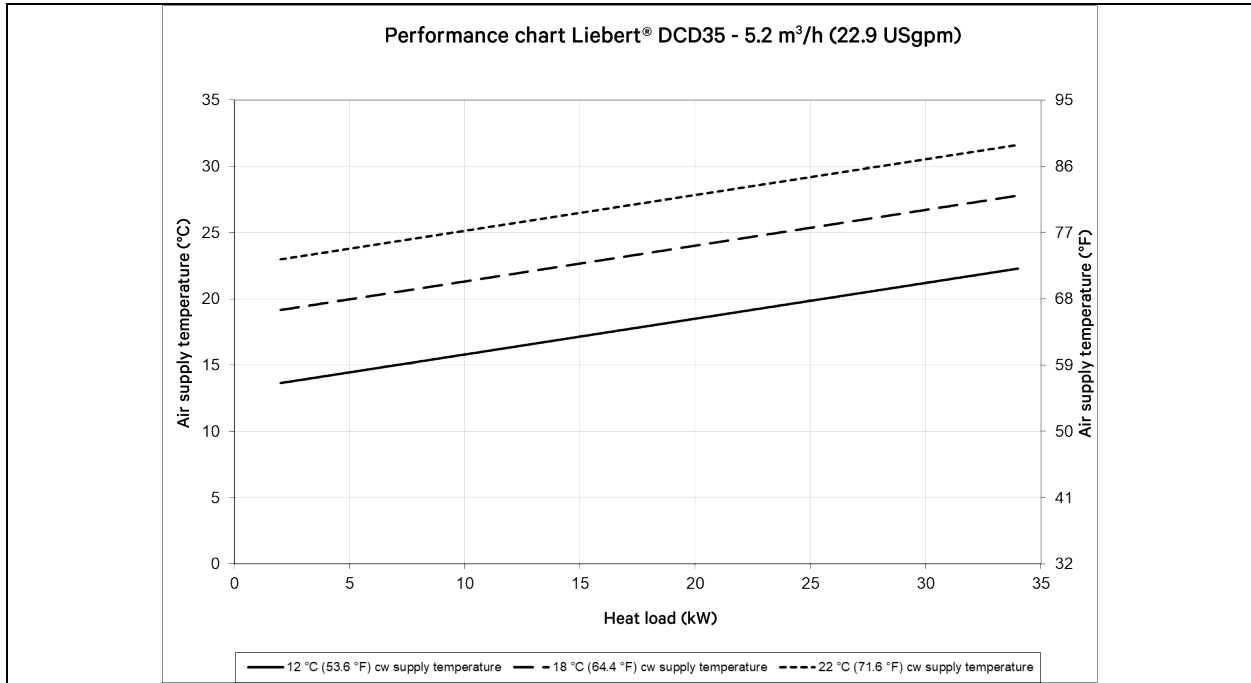

Figure 10.2 Performance Chart Vertiv™ Liebert® DCD35 – 2

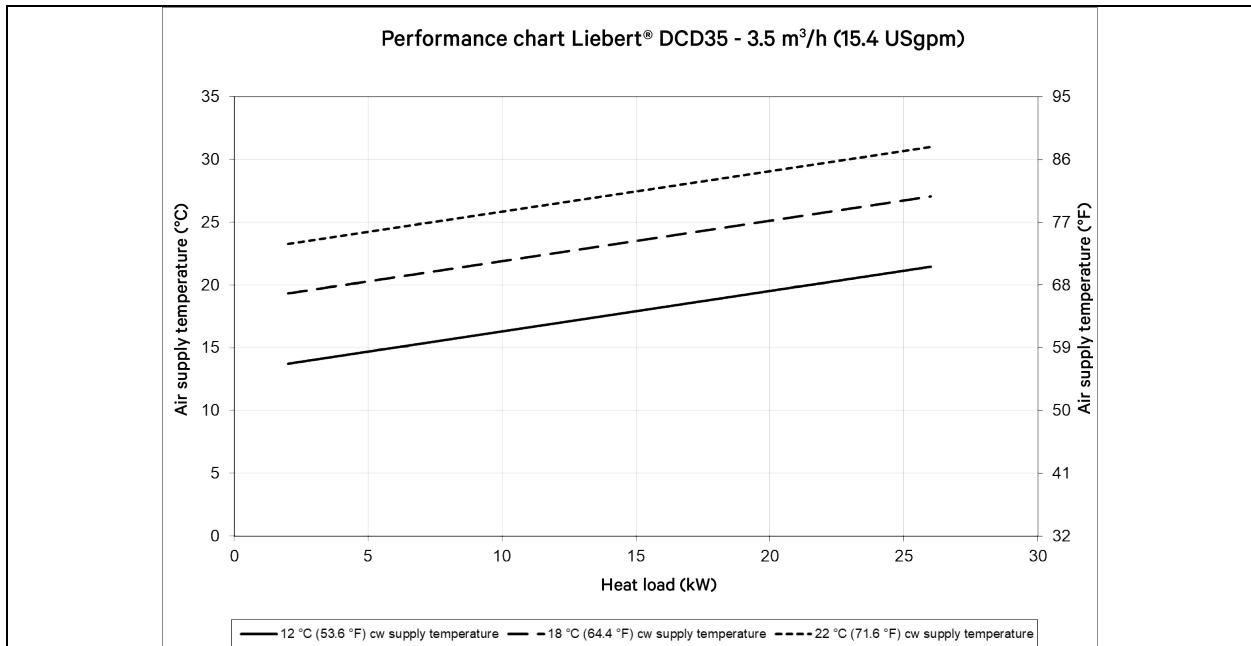

Figure 10.3 Performance Chart Vertiv™ Liebert® DCD35 – 3

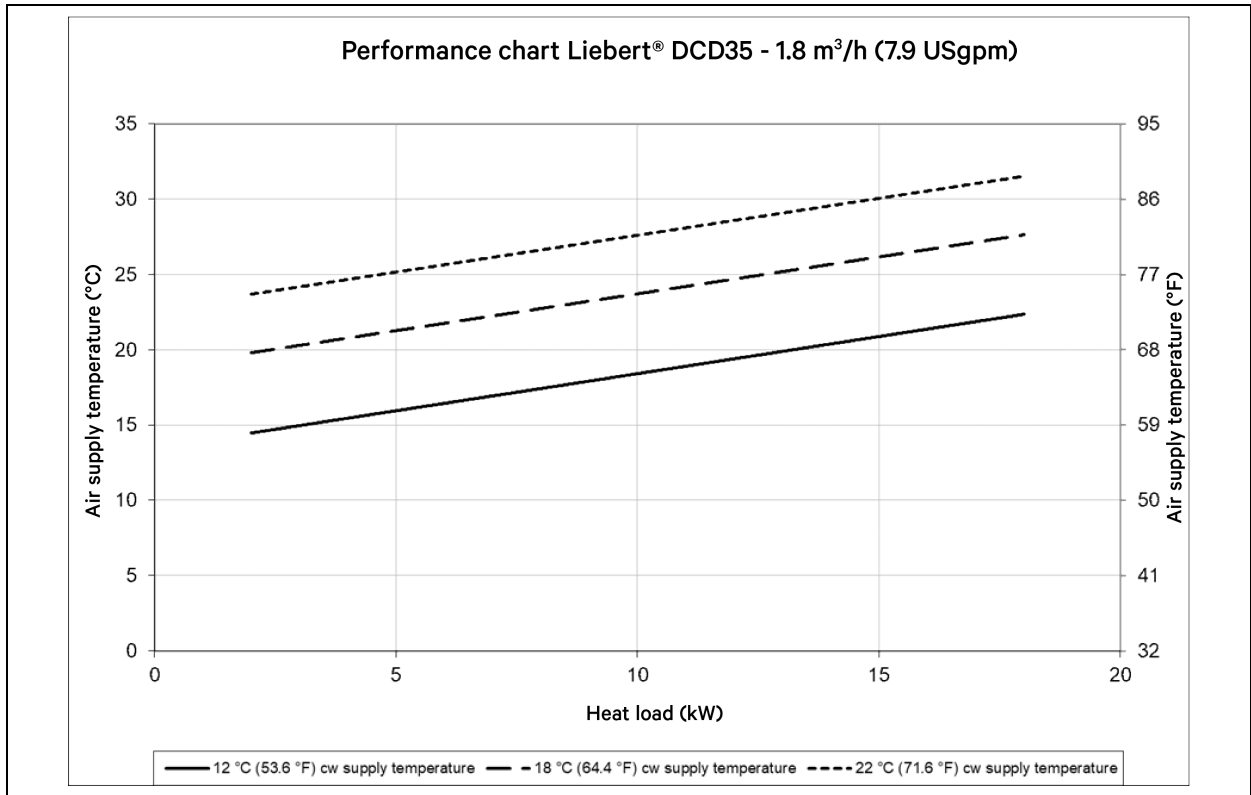

Figure 10.4 Cooling Air Pressure Drop Vertiv™ Liebert® DCD35

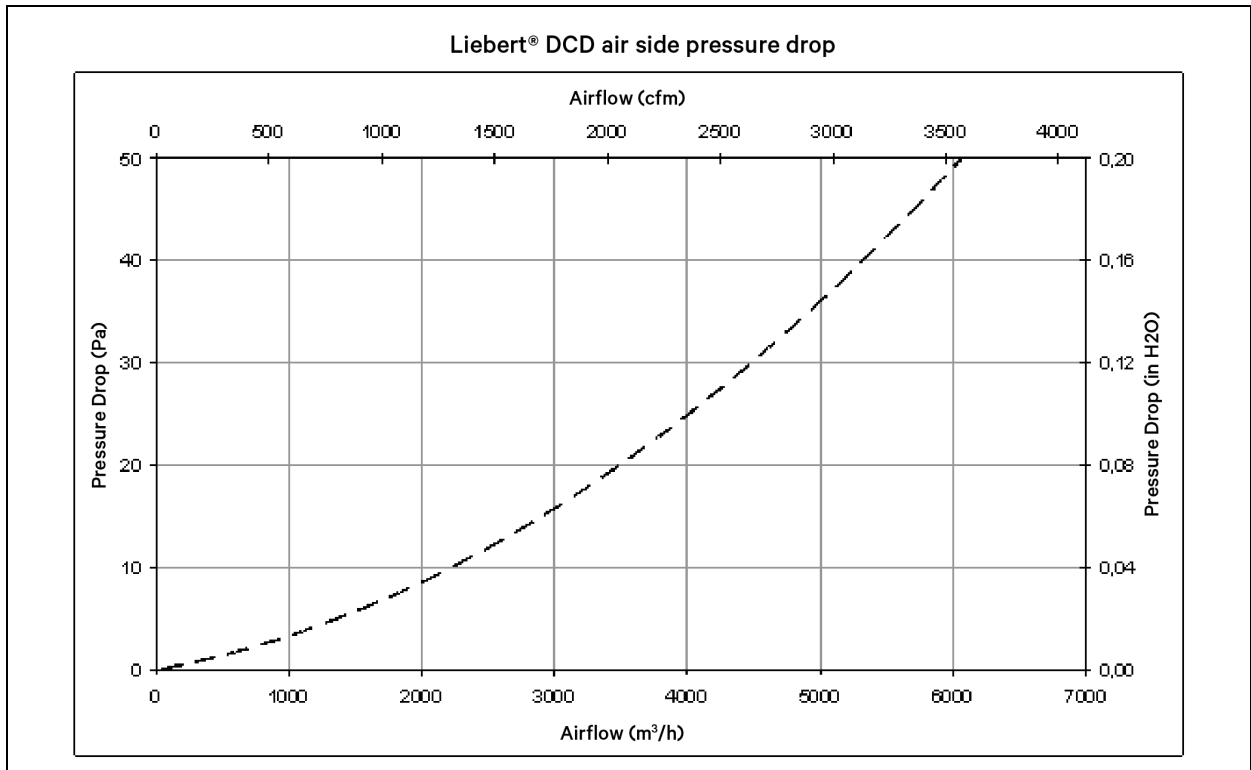

Figure 10.5 Chilled Water Pressure Drop Vertiv™ Liebert® DCD35

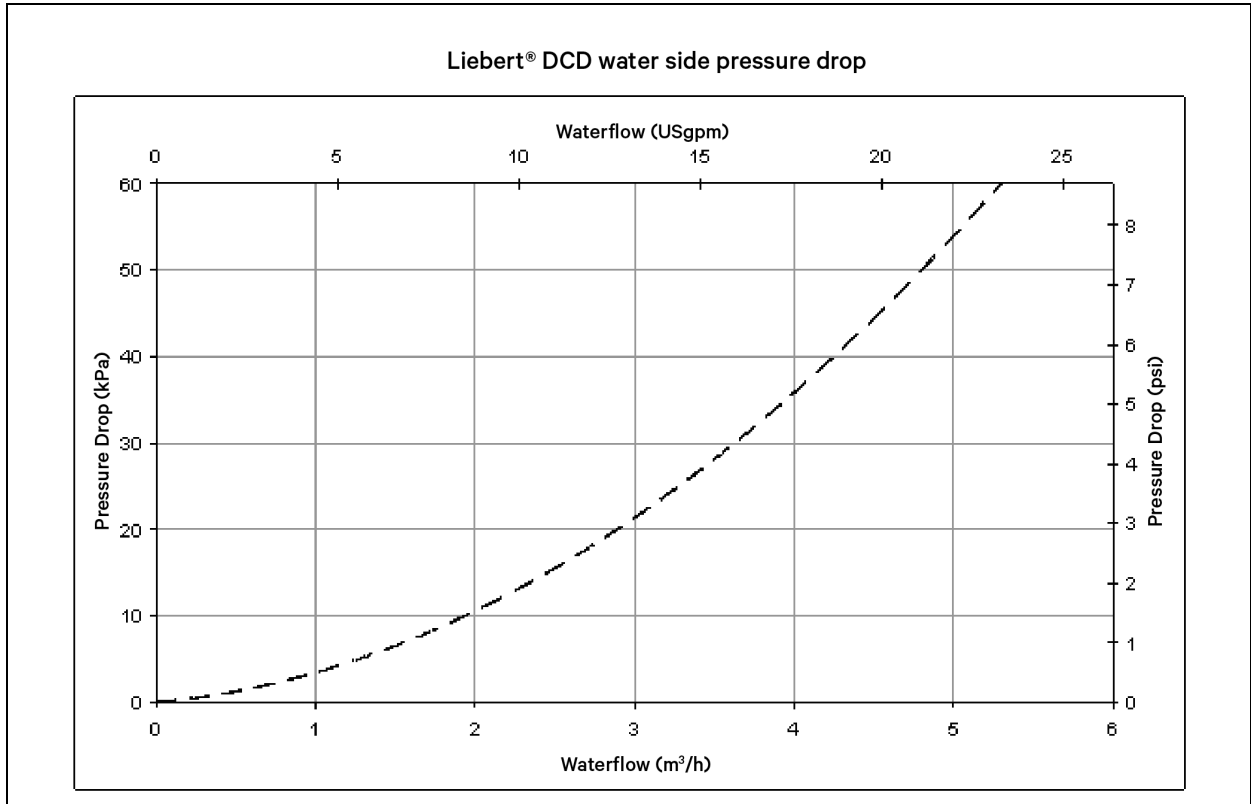
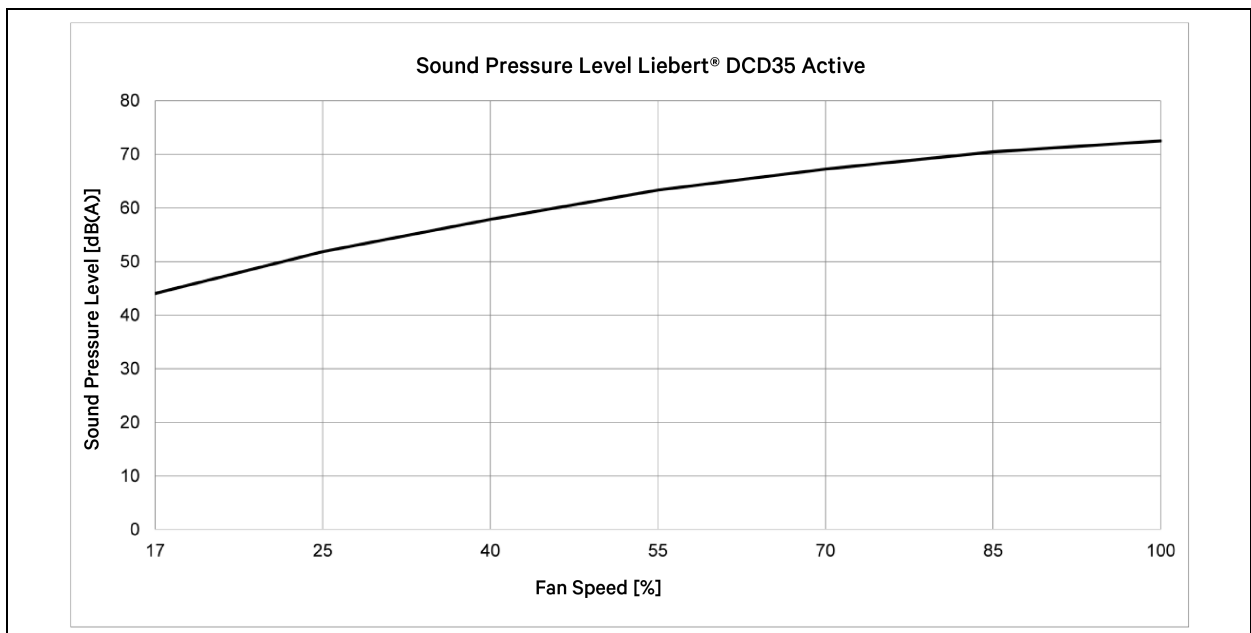

Figure 10.6 Sound Pressure Level Vertiv™ Liebert® DCD35 Active at 1 m Distance According to ISO 7779



F.2 Performance Charts for Vertiv™ Liebert® DCD47

Figure 10.7 Performance Chart Liebert® DCD47 – 1

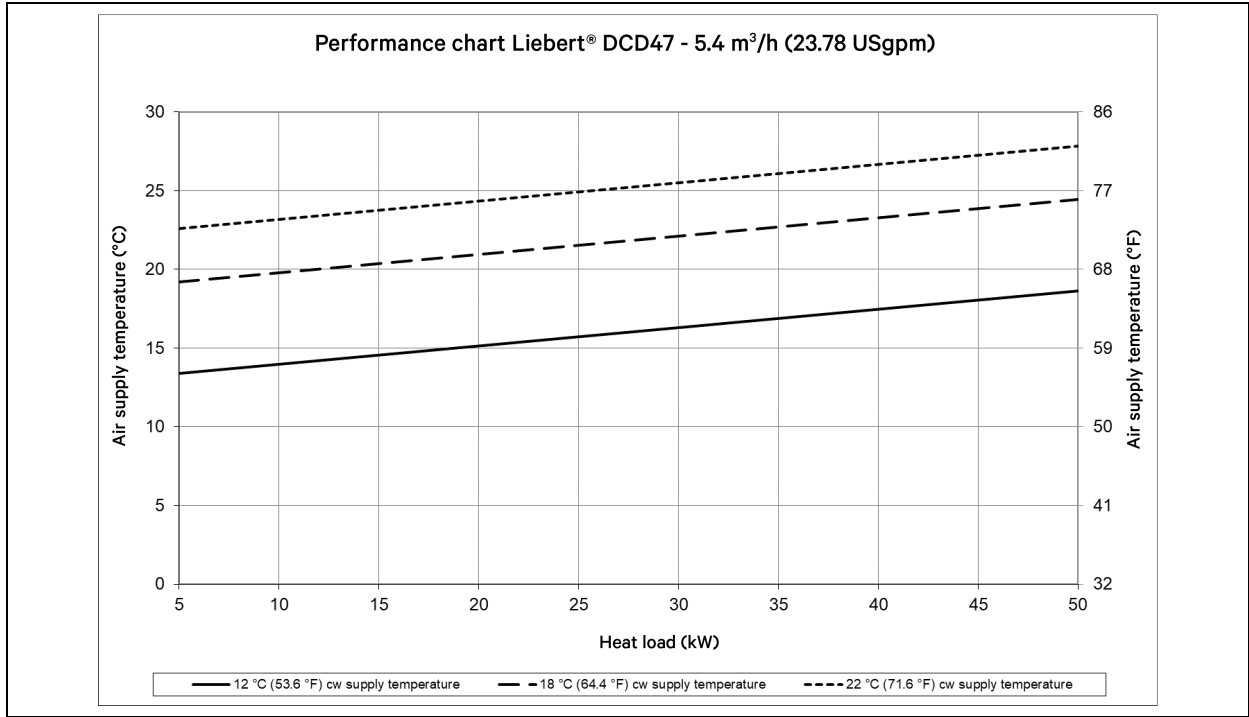

Figure 10.8 Performance Chart Vertiv™ Liebert® DCD47 – 2

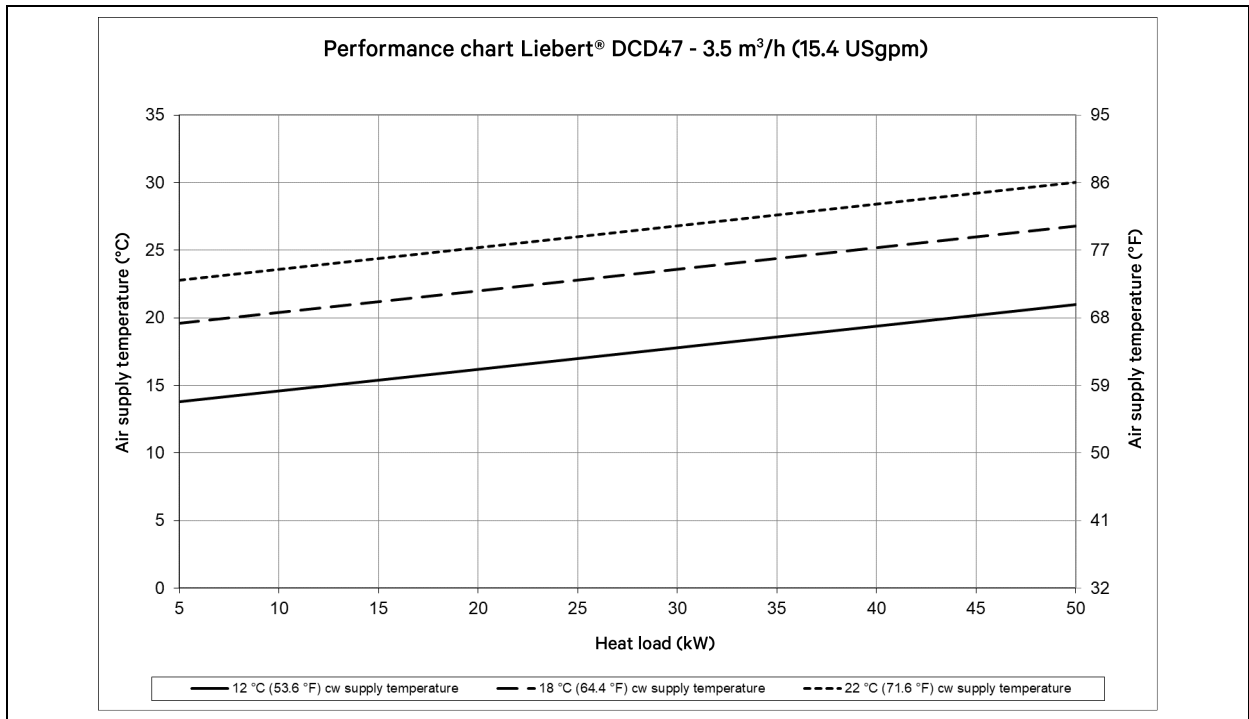

Figure 10.9 Performance Chart Vertiv™ Liebert® DCD47 – 3

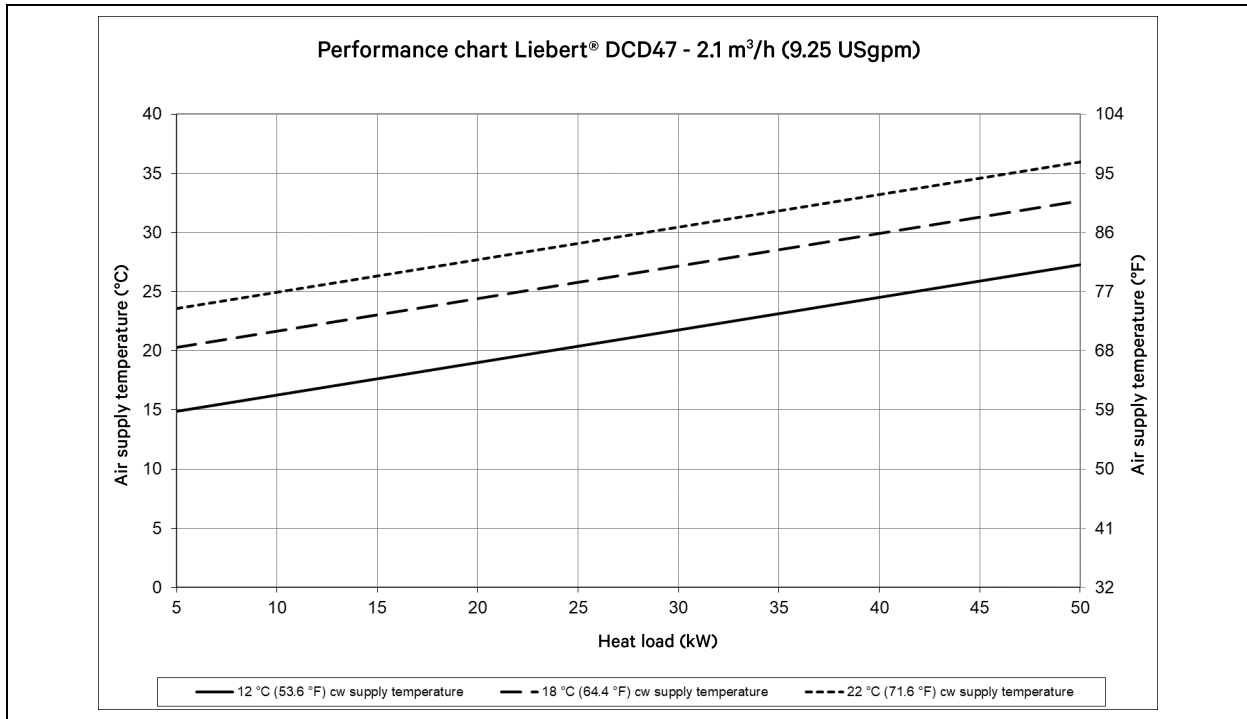

Figure 10.10 Cooling Air Pressure Drop Vertiv™ Liebert® DCD47

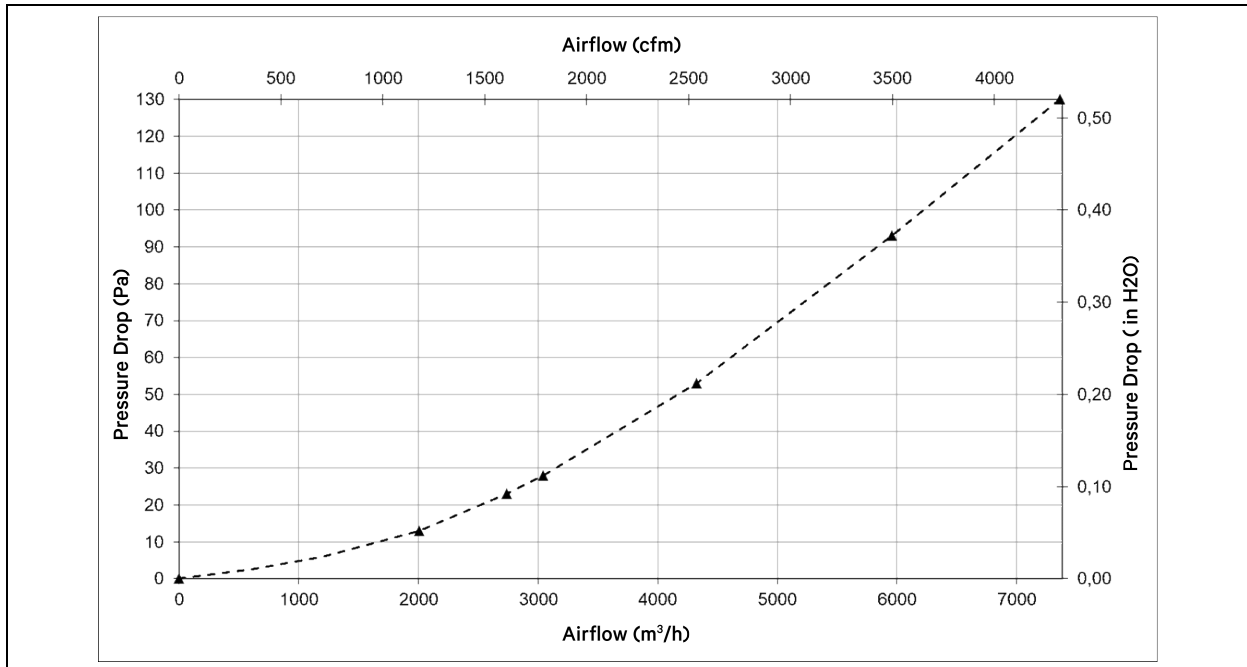

Figure 10.11 Chilled Water Pressure Drop Vertiv™ Liebert® DCD47

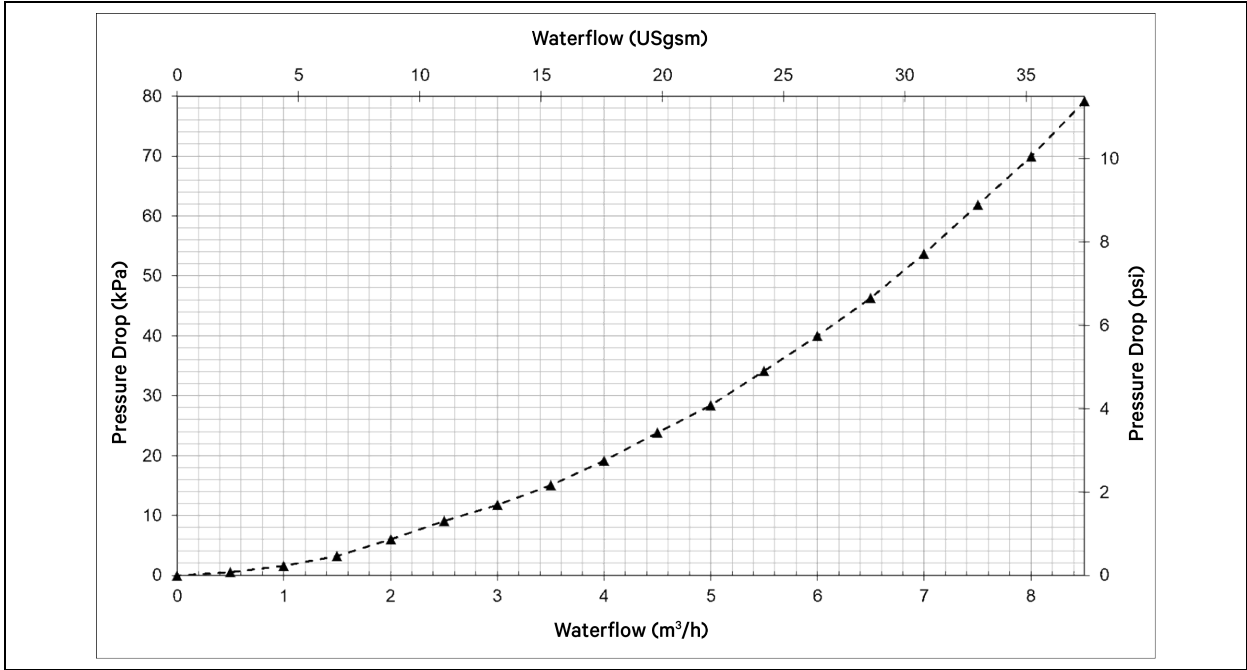
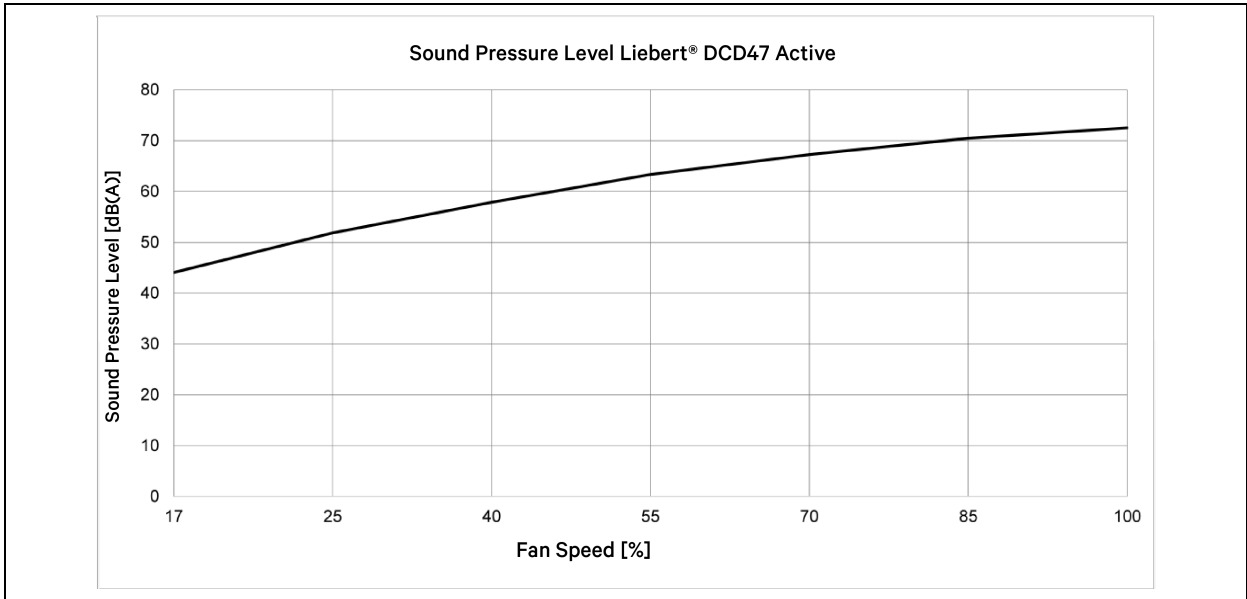

Figure 10.12 Sound Pressure Level Vertiv™ Liebert® DCD47 Active at 1 m Distance According to ISO 7779



F.3 Performance Charts for Vertiv™ Liebert® DCD50

Figure 10.13 Performance Chart Liebert® DCD50 – 1

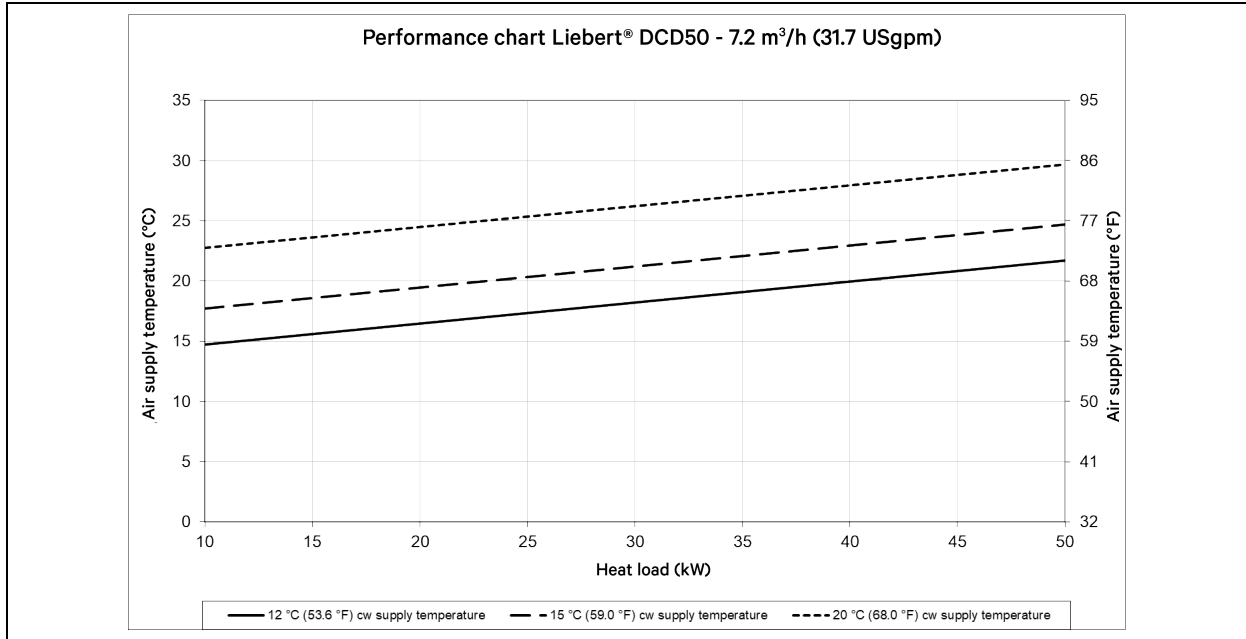

Figure 10.14 Performance Chart Vertiv™ Liebert® DCD50 – 2

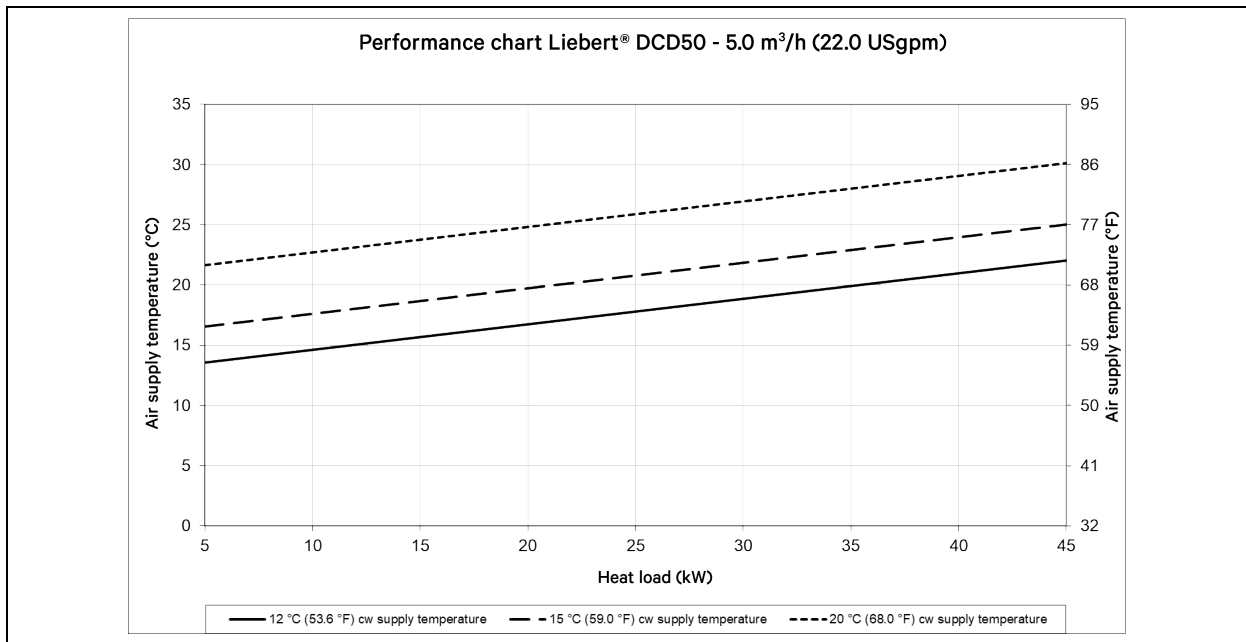

Figure 10.15 Performance Chart Vertiv™ Liebert® DCD50 – 3

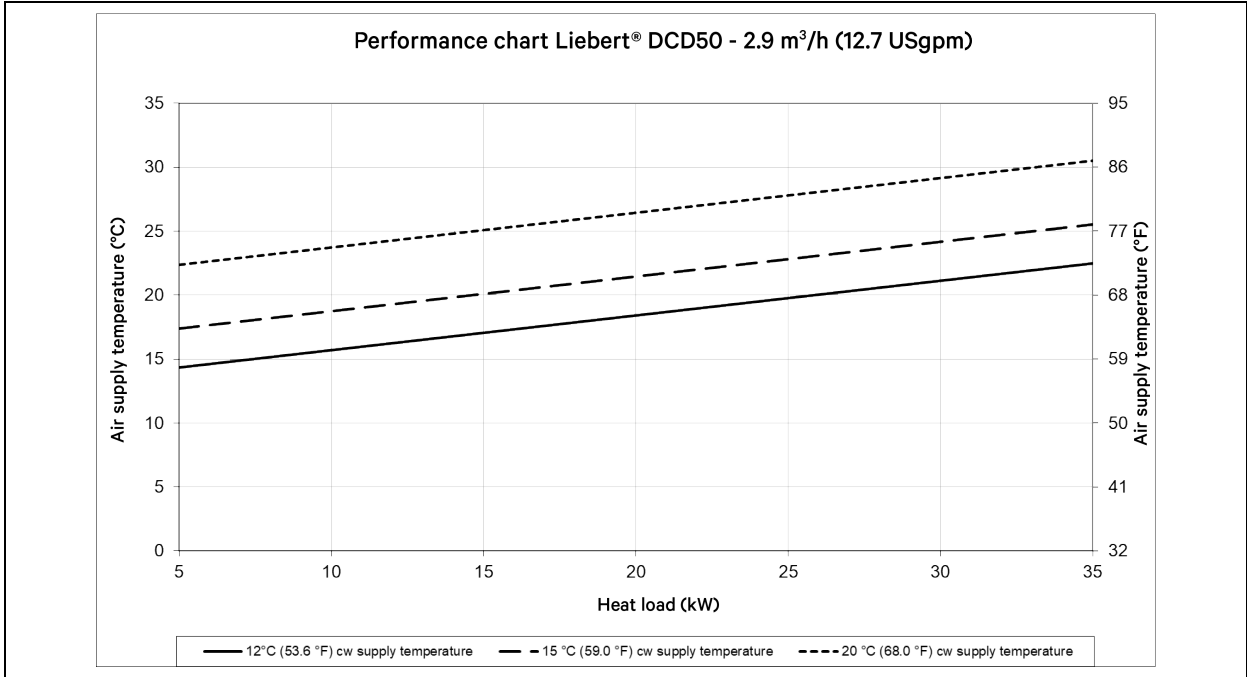

Figure 10.16 Cooling Air Pressure Drop Vertiv™ Liebert® DCD50

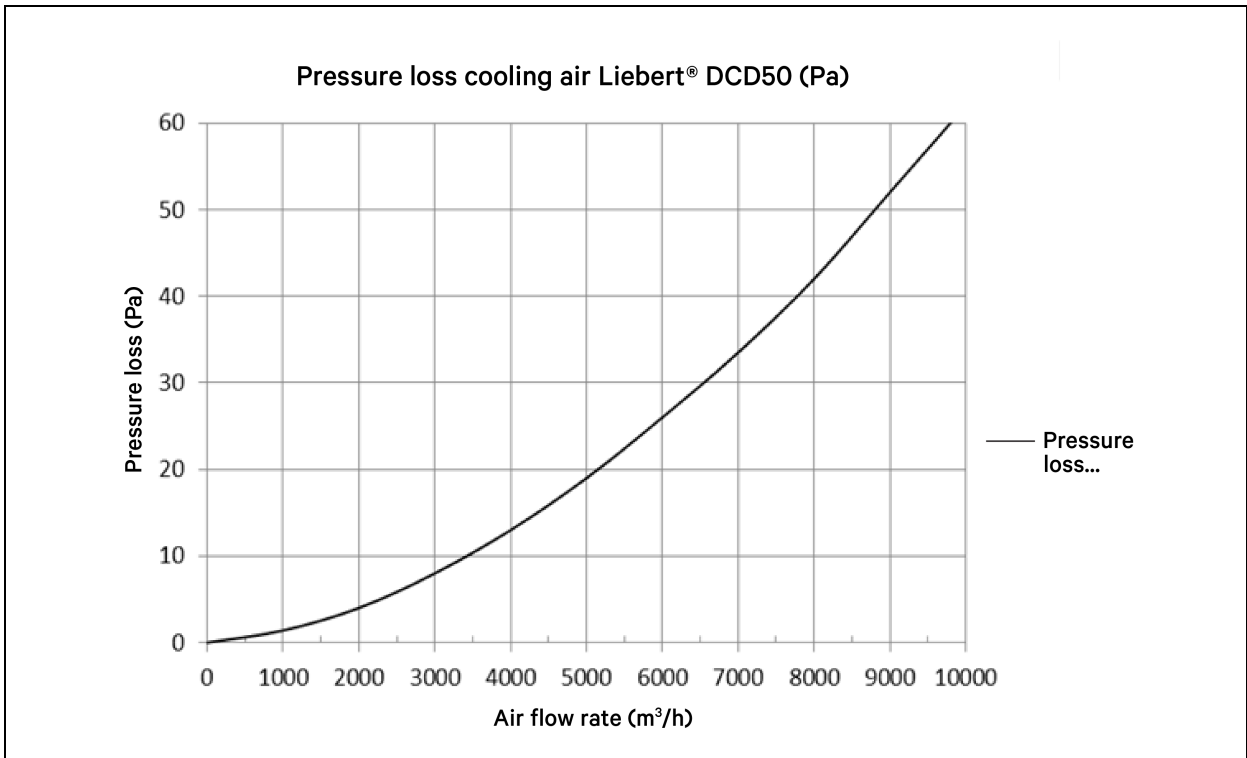

Figure 10.17 Chilled Water Pressure Drop Vertiv™ Liebert® DCD50

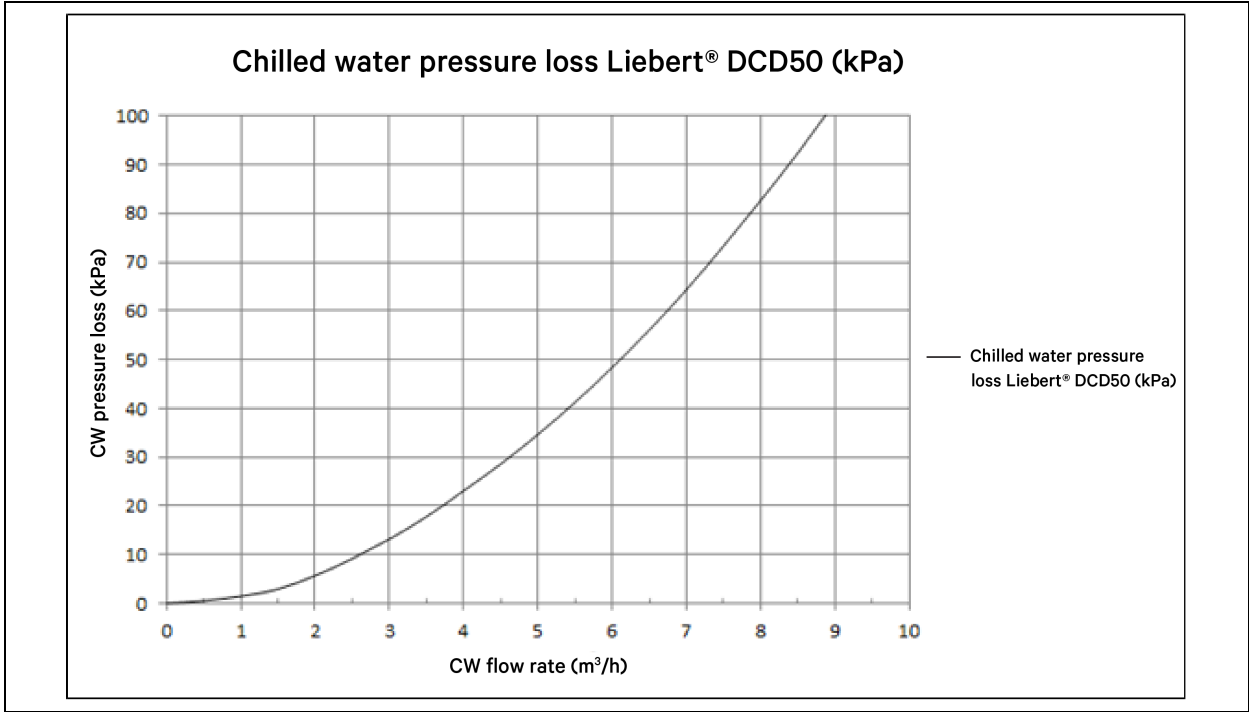
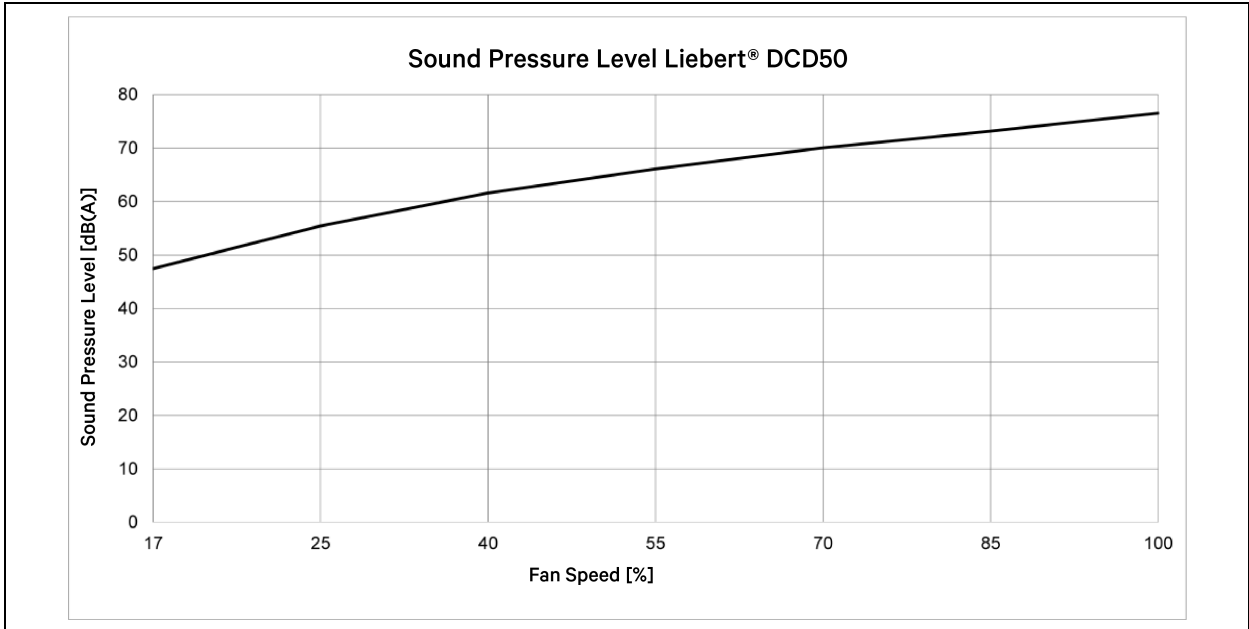

Figure 10.18 Sound Pressure Level Vertiv™ Liebert® DCD50 Active at 1 m Distance According to ISO 7779



Appendix G: Submittal Drawings

The dimensions stated in Table 10.4 on the facing page are indicated in Figure 10.19 below.

Figure 10.19 Submittal Drawings – Vertiv™ Liebert® DCD (1 mm = 0.0394")

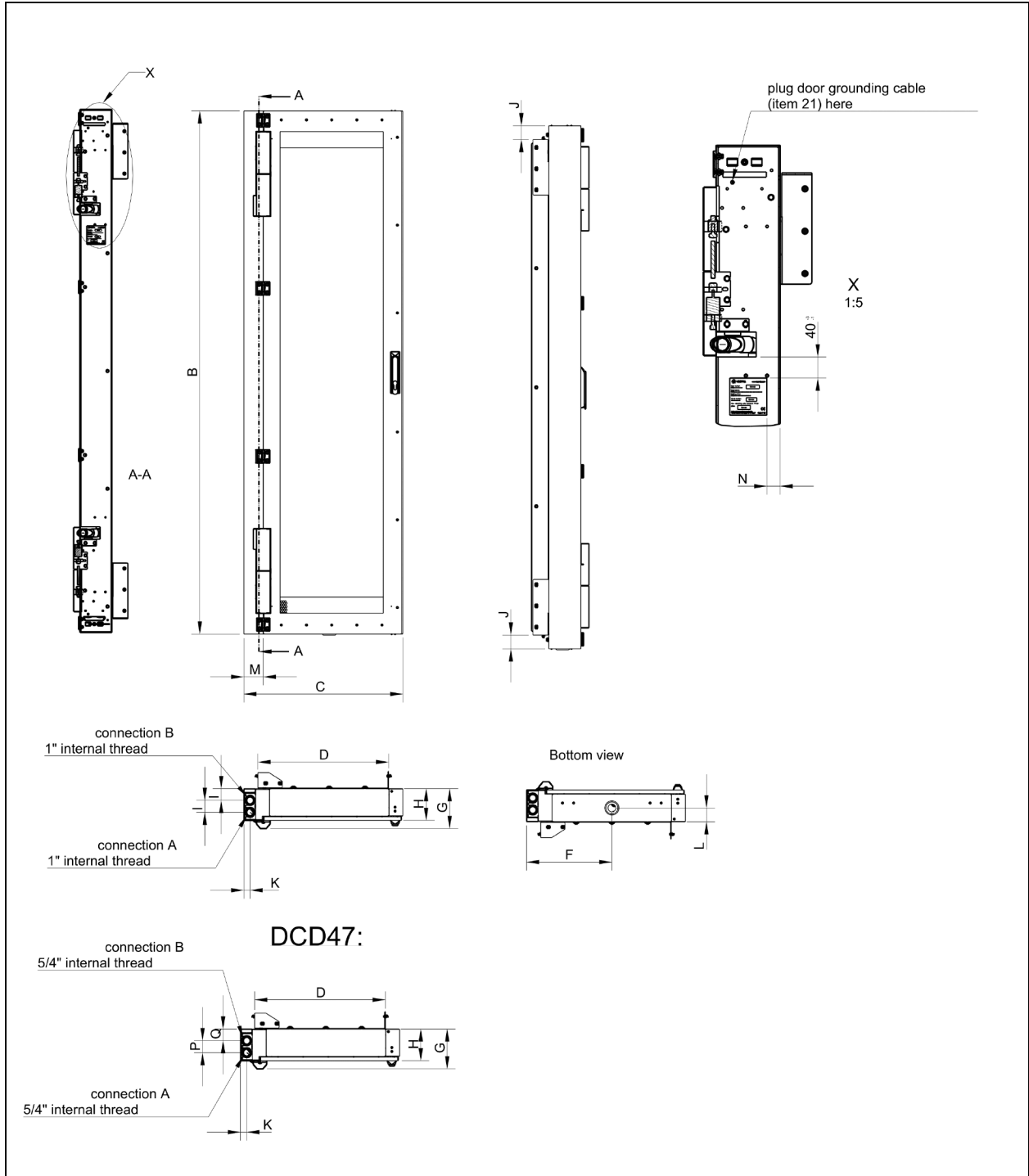

Table 10.4 Unit Dimensions

	2000 mm (78-3/4")			2200 mm (85-3/4")		
600 mm (23-5/8")	B=1954 mm	C=600 mm	D=493 mm	B=2176 mm	C=600 mm	D=493 mm
	F=322 mm F=33 mm*	G=151 mm G=22 mm*	H=120 mm H=185 mm*	F=322 mm F=332 mm*	G=151 mm G=221 mm*	H=120 mm H=185 mm*
	I=45 mm	J=40.7 mm	K=24 mm K=32 mm*	I=45 mm	J=40.7 mm	K=24 mm K=32 mm*
	L=52 mm L=84,5 mm*	M=73 mm M=93 mm*	N=25 mm	L=52 mm L=84,5 mm*	M=73 mm M=93 mm*	N=25 mm
	P=64.7 mm*, Q=54.5 mm*			P=64.7 mm*, Q=54.5 mm*		
	B=77-7/8"	C=23-5/8"	D=19-3/8"	B=85-3/4"	C=23-5/8"	D=19-3/8"
	F=12-5/8" F=13-1/8"	G=6" G=8-6/8"	H=4-6/8" H=7-2/8"	F=12-5/8" F=13-1/8"	G=6" G=8-6/8"	H=4-6/8" H=7-2/8"
	I=1-6/8"	J=1-5/8"	K=1" K=1-2/8"	I=1-6/8"	J=1-5/8"	K=1" K=1-2/8"
	L=2" L=3-3/8"	M=2-7/8" M=3-5/8"	N=1"	L=2" L=3-3/8"	M=2-7/8" M=3-5/8"	N=1"
	P=2-4/8**, Q=2-1/8**			P=2-4/8**, Q=2-1/8**		
800 mm (31-1/2")	B=1954 mm	C=800 mm	D=693 mm	B=2176 mm	C=800 mm	D=693 mm
	F=422 mm F=432 mm*	G=151 mm G=221 mm*	H=120 mm H=185 mm*	F=422 mm F=432 mm*	G=151 mm G=221 mm*	H=120 mm H=185 mm*
	I=45 mm	J=40.7 mm	K=24 mm K=32 mm*	I=45 mm	J=40.7 mm	K=24 mm K=32 mm*
	L=52 mm L=84,5 mm*	M=73 mm M=93 mm*	N=25 mm	L=52 mm L=84,5 mm*	M=73 mm M=93 mm*	N=25 mm
	P=64.7 mm*, Q=54.5 mm*			P=64.7 mm*, Q=54.5 mm*		
	B=77-7/8"	C=31-1/2"	D=27-1/4"	B=85-3/4"	C=31-1/2"	D=27-1/4"
	F=16-5/8" F=17"	G=6" G=8-6/8"	H=4-6/8" H=7-2/8"	F=16-5/8" F=17"	G=6" G=8-6/8"	H=4-6/8" H=7-2/8"
	I=1-6/8"	J=1-5/8"	K=1" K=1-2/8"	I=1-6/8"	J=1-5/8"	K=1" K=1-2/8"
	L=2" L=3-3/8"	M=2-7/8"	N=1"	L=2" L=3-3/8"	M=2-7/8"	N=1"
	P=2-4/8**, Q=2-1/8**			P=2-4/8**, Q=2-1/8**		
Dimensions with * are valid for Vertiv™ Liebert® DCD47.						

The dimensions stated in **Table 10.5** below are indicated in **Figure 10.20** below .

Figure 10.20 Aluminum Frame Submittal Drawing (1 mm = 0.0394")

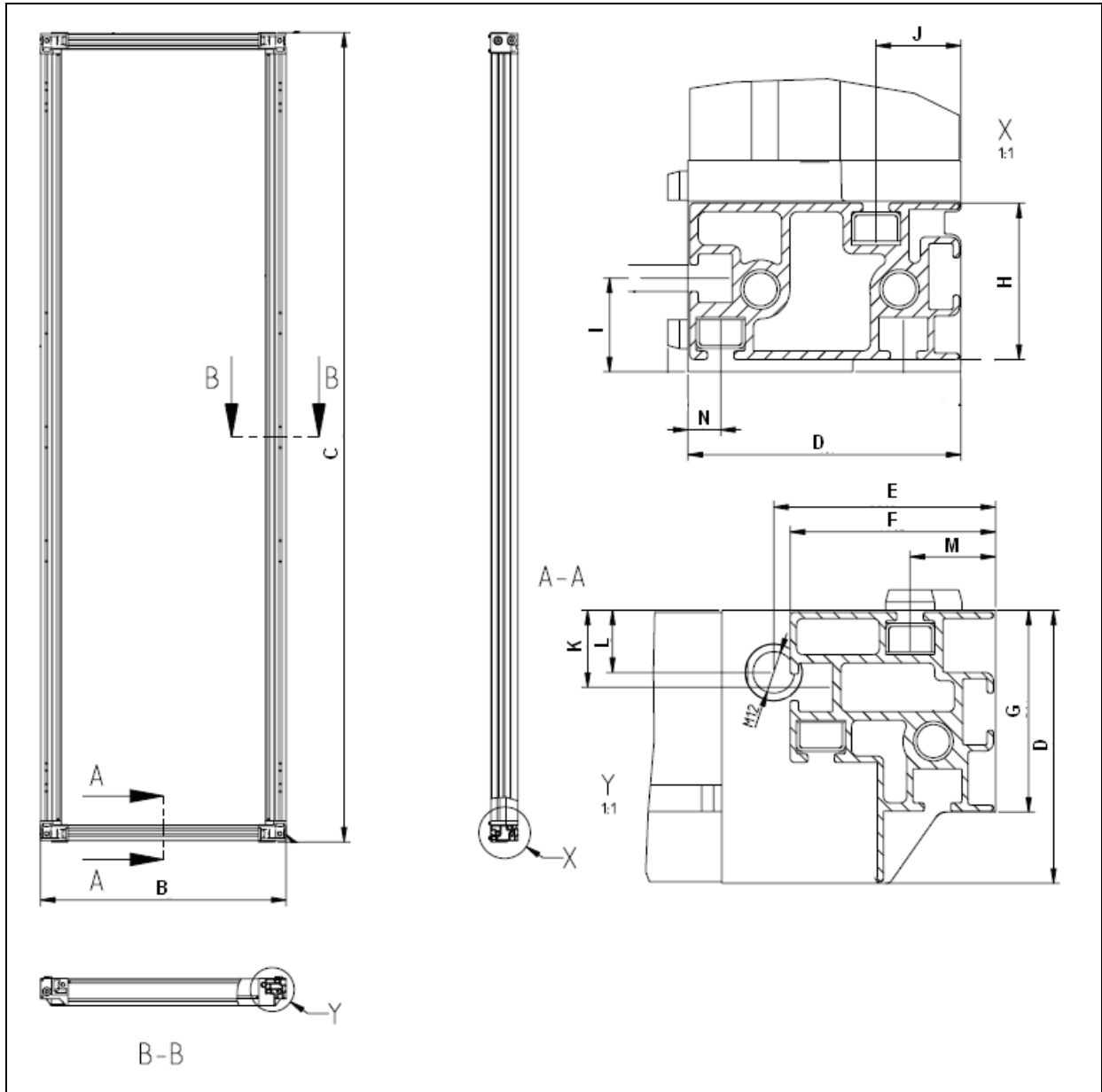

Table 10.5 Aluminium Frame Dimensions

Dimensions in mm				Dimensions in inch			
B=592 mm (W600) / 692 mm (W700) / 792 mm (W800)	C=1954 mm	D=65.9 mm	E=53.5 mm	B=23-2/8" (W600) / 27-2/8" (W700) / 31-2/8" (W800)	C=76-7/8"	D=2-5/8"	E=2-1/8"
F=49.5 mm	G=48.7 mm	H=37.7 mm	I=22.6 mm	F=2"	G=1-7/8"	H=1-1/2"	I=7/8"
J=20.5 mm	K=18.6 mm	L=15 mm	M=20.6 mm	J=6/8"	K=6/8"	L=5/8"	M=6/8"
N=7.9 mm				N=2/8"			

Connect with Vertiv on Social Media



<https://www.facebook.com/vertiv/>



<https://www.instagram.com/vertiv/>



<https://www.linkedin.com/company/vertiv/>



<https://www.twitter.com/Vertiv/>



Vertiv.com | Vertiv Headquarters, 505 N Cleveland Ave, Westerville, OH, 43082, USA

© 2023 Vertiv Group Corp. All rights reserved. Vertiv™ and the Vertiv logo are trademarks or registered trademarks of Vertiv Group Corp. All other names and logos referred to are trade names, trademarks or registered trademarks of their respective owners. While every precaution has been taken to ensure accuracy and completeness here, Vertiv Group Corp. assumes no responsibility, and disclaims all liability, for damages resulting from use of this information or for any errors or omissions.

SL-11522_REVJ_02-23