



Liebert[®] DateMate

System Design Catalog

1.5-ton to 3-ton (5-kW to 10.5-kW) Capacity,
Air, Water/Glycol, Chilled Water; 50 and 60 Hz

The information contained in this document is subject to change without notice and may not be suitable for all applications. While every precaution has been taken to ensure the accuracy and completeness of this document, Vertiv assumes no responsibility and disclaims all liability for damages result from use of this information or for any errors or omissions.

Vertiv recommends installing a monitored fluid detection system that is wired to activate the automatic closure of field-installed coolant fluid supply and return shut off valves, where applicable, to reduce the amount of coolant fluid leakage and consequential equipment and building damage. Refer to local regulations and building codes relating to the application, installation, and operation of this product. The consulting engineer, installer, and/or end user is responsible for compliance with all applicable laws and regulations relation to the application, installation, and operation of this product.

The products covered by this instruction manual are manufactured and/or sold by Vertiv. This document is the property of Vertiv and contains confidential and proprietary information owned by Vertiv. Any copying, use, or disclosure of it without the written permission of Vertiv is strictly prohibited.

Names of companies and products are trademarks or registered trademarks of the respective companies. Any questions regarding usage of trademark names should be directed to the original manufacturer.

Technical Support Site

If you encounter any installation or operational issues with your product, check the pertinent section of this manual to see if the issue can be resolved by following outlined procedures.

Visit <https://www.vertiv.com/en-us/support/> for additional assistance.

TABLE OF CONTENTS

1 Introduction	1
1.1 Designed to Match Computer and Electronic Equipment Needs—from Installation to Operation	1
1.2 AHRI Certified	2
1.3 Agency Listed	2
2 Features and Options	3
2.1 Standard Features	3
2.1.1 Evaporator Section—Split Systems	3
2.1.2 Condensing Unit Section—Remote Split Systems	3
2.1.3 Condensing Unit Section—Close-coupled	3
2.1.4 Chilled Water Units	4
2.1.5 System Controls	4
2.2 Optional Factory-Installed Features	5
2.2.1 Evaporator/Chilled Water Unit Options	5
2.2.2 Optional Configurations—Prop Fan Condensing Units	5
2.2.3 Optional Configurations—Water/Glycol Condensing Units	5
2.3 Ship Loose Accessories—Field-Installed	6
2.3.1 Remote Monitoring, Autochangeover, and Leak Detection Equipment	6
3 Nomenclature	7
3.1 System Configurations	7
3.2 Nomenclature for Evaporator and Chilled Water Units	10
3.3 Nomenclature for Condensing units	11
3.3.1 Outdoor Prop Fan Condensing Units for Air Cooled Systems	11
3.3.2 Indoor Condensing Units for Air Cooled Systems	12
3.3.3 Close-coupled Condensing Unit for Water/Glycol Cooled Systems	13
3.3.4 Remote, Indoor Water/Glycol Cooled Condensing Units	14
4 System Data	15
4.1 Air Cooled Systems—Capacity and Performance Data	15
4.2 Water/Glycol Cooled Systems—Capacity and Performance Data	19
4.3 Chilled Water Systems—Capacity and Performance Data	23
4.4 Planning Dimensions	25
5 Electrical Data	27
5.1 Evaporators and Chilled Water Units Electrical Data	27
5.2 Close-coupled Water/Glycol Units Electrical Data	27
5.3 Indoor, Remote Condensing Units Electrical Data	28
5.4 Outdoor Condensing Units Electrical Data	29
5.5 Electrical Field Connections	30
6 Piping	31
6.1 Refrigerant Charge Requirements	31

6.1.1 Refrigerant-line Sizes and Equivalent Lengths32

6.1.2 Piping when Condensing Unit is Above or Below Evaporator33

6.2 Glycol Loop Piping34

Appendices35

Appendix A: Technical Support and Contacts35

Appendix B: Guide Specifications37

Appendix C: Submittal Drawings39

1 Introduction

1.1 Designed to Match Computer and Electronic Equipment Needs— from Installation to Operation

Installed on the floor or on the wall, Vertiv™ Liebert® DataMate Thermal Management systems control the cooling, humidity and air distribution required by sensitive electronic equipment. A range of sizes and configurations is available to meet varying site needs.

The Liebert® DateMate is also easy to use. Advanced microprocessor technology allows easy, precise control, and menu-driven monitoring keeps you informed of system operation through the LCD readout. These features, combined with Vertiv quality construction and reliable components, guarantee satisfaction from installation through operation.

Liebert® Thermal Management

Liebert® Thermal Management systems control the temperature and humidity required for computers and other sensitive electronic equipment. The Liebert® DateMate provides complete control on an around-the-clock basis and the high sensible-heat ratio required by sensitive electronic equipment.

Easy Installation

The Liebert® DateMate is a split-system evaporator combined with a remote air, water or glycol cooled condensing unit, a close-coupled water/glycol condensing unit, or is a self-contained, chilled water unit. Each split system has thermostat-type wiring to controls and condensing unit.

Easy to Service

Low-maintenance components are easily accessed through removable front panels. Routine maintenance service can be performed quickly and easily. Spare parts are always in Vertiv inventory and available on short notice.

Advanced Control Technology

A menu-driven microprocessor control system provides precise temperature and humidity control and accurate alarm setpoints. Using touch-sensitive buttons, the wall-mounted monitor/control panel allows you to select and display temperature and other monitored parameters.

High Efficiency

High sensible heat ratio, scroll compressor, and precise microprocessor control allow the system to operate efficiently.

Space-saving Design

Models available to fit in any room without disrupting work-station layout. Units require 5 ft² (0.5 m²) or less of floor space or may be mounted on a wall.

Reliable

The Liebert® DateMate family installed base is a testimony to the system reliability.

1.2 AHRI Certified

The Vertiv™ Liebert® DateMate 60-Hz system is AHRI Certified, the trusted mark of performance assurance for heating, ventilation, air conditioning and commercial refrigeration equipment, using AHRI Standard 1360.



1.3 Agency Listed

Standard 60-Hz units are CSA Certified to the harmonized U.S. and Canadian product safety standard CSA C22.2 No 236/UL 1995 for "Heating and Cooling Equipment" and are marked with the CSA c-us logo.



2 Features and Options

2.1 Standard Features

2.1.1 Evaporator Section—Split Systems

The DateMate systems consist of an evaporator section matched with an outdoor air cooled condensing unit, indoor air-cooled condensing unit or indoor water/glycol cooled condensing unit.

The evaporator unit includes an evaporator coil, filter-drier, expansion valve, two-speed centrifugal blower assembly, galvanized-steel drain pan, cleanable filters, and microprocessor control with wall-mounted display panel. The floor- or wall-mounted unit is constructed of galvanized-steel with powder-coated, removable exterior panels. A reversible discharge grille lets you redirect air flow. The system is designed for R-407C refrigerant. Suction and liquid lines are spun closed, and filled with an inert gas holding charge.

2.1.2 Condensing Unit Section—Remote Split Systems

Outdoor Air Cooled Condensing Units

The outdoor prop fan condensing unit includes scroll compressor, condenser coil, propeller fan, liquid-line solenoid valve, high-pressure switch, Vertiv™ Liebert® Lee-Temp head-pressure control, and hot-gas bypass. The condensing unit is designed for R-407C refrigerant and operates in outdoor locations at ambient temperatures ranging from -30°F to 95°F (-34°C to 35°C). Suction and liquid lines are spun closed, and filled with an inert gas holding charge.

Indoor Air Cooled Condensing Units

Indoor, air cooled, centrifugal fan condensing units include scroll compressor, condenser coil, factory-mounted disconnect switch, belt-driven centrifugal blower assembly, high pressure switch, Liebert® Lee-Temp head-pressure control system, hot-gas bypass and liquid-line solenoid valve. Unit must be mounted indoors. Condensing unit is designed for R-407C refrigerant and will operate with outdoor air temperatures ranging from -30°F to 95°F (-34°C to 35°C). Suction and liquid lines are spun closed, and filled with an inert gas holding charge. Available in 2-ton and 3-ton models.

Indoor Water/Glycol Cooled Condensing Units

Indoor Remote Water/Glycol Condensing Units include scroll compressor, factory-mounted disconnect, coaxial condenser, hot-gas bypass, high-head-pressure switch, and two-way water/glycol-regulating valve designed for 150 psi (1034.3 kPa). Condensing unit is designed for R-407C refrigerant and can be used on a water or glycol cooling loop. Suction and liquid lines are spun closed, and filled with an inert gas holding charge.

2.1.3 Condensing Unit Section—Close-coupled

The Close-coupled Water/Glycol Condensing Unit attaches to the split-system evaporator to become a single wall- or floor-mounted unit.

Indoor close-coupled water/glycol condensing units include scroll compressor, brazed-plate condenser and 2-way water-regulating valve. Unit is available in 60-Hz models only. Design water/glycol pressure is 150 psi (1034 kPa). Suction and liquid lines are spun closed, and filled with an inert gas holding charge.

2.1.4 Chilled Water Units

Chilled water models are self-contained and include a chilled water coil, two-speed, centrifugal blower, two-way valve with an On/Off actuator, cleanable filters, and microprocessor control with wall-mounted display panel. Design pressure is 300 psi (2068 kPa), 60 psi (414 kPa) close-off differential.

2.1.5 System Controls

System controls include a microprocessor control board mounted in the evaporator/chilled water unit and a wall-mounted interface with a two-line, 16-character liquid crystal display. An eight-key, membrane keypad for setpoint/program control, unit On/Off, fan speed, and alarm silence is below the LCD screen. It provides temperature setpoint and sensitivity adjustment, humidity setpoint and sensitivity adjustment, digital display of temperature, humidity, setpoints, sensitivities, fan speed, and alarm conditions.

The wall-box is field-wired to the microprocessor control using standard four-conductor, shielded thermostat wire (field-supplied). The temperature and humidity sensors are in the wall box, which can be installed up to 300 ft (91.4 m) from the evaporator unit when using a remote temperature/humidity sensor in the conditioned space. The unit-mounted control board also includes common-alarm terminals and shut-down terminals. The unit automatically restarts after a power outage.

Figure 2.1 Wall-box

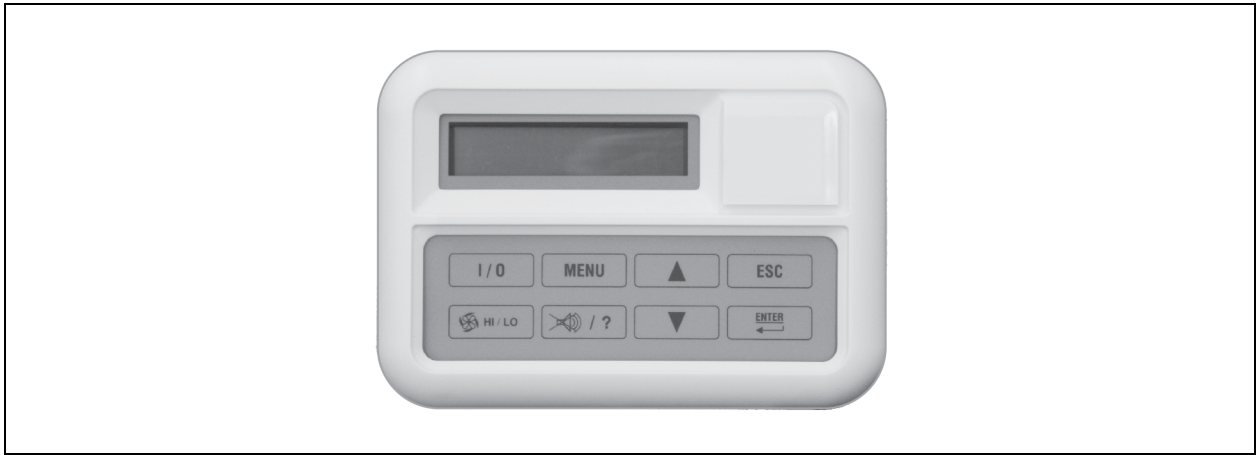

Other Standard Control Features

- Adjustable auto restart
- 5 day/2 day setback
- Password protection
- Alarm enable/disable
- Self-diagnostics
- Calibrate sensors
- Predictive humidity control
- Common alarm output
- Remote shut-down terminals

2.2 Optional Factory-Installed Features

2.2.1 Evaporator/Chilled Water Unit Options

Reheat

Electric Reheat includes a low-watt, tubular reheat element with non-corrosive metal sheath provides single-stage, non-ionizing to maintain room dry-bulb temperature.

Humidifier/Reheat

Humidifier/Electric-reheat Package is available for complete humidity control. The canister humidifier includes a steam-generating type humidifier with automatic flushing circuit, inlet strainer, drain, 1-in. (25.4 mm) air gap on fill line and solenoid valves. Humidifier problem alarm annunciates at the wall-mounted display panel. Maximum humidifier water supply pressure is 150 psi (1034 kPa).

2.2.2 Optional Configurations—Prop Fan Condensing Units

Outdoor Prop Fan Condensing Units are available in the following optional configurations:

- High-ambient models for providing catalog capacities at ambient temperatures up to 105°F (40°C).
- Vertiv™ Liebert® Quiet-Line models for low-noise-level conditions (below 58 dBA) and for providing catalog capacities at ambient temperatures up to 95°F (35°C).
- Condenser coils can be epoxy-coated with UV topcoat for extended coil life in corrosive environments, such as coastal areas.

2.2.3 Optional Configurations—Water/Glycol Condensing Units

Remote Water/Glycol Condensing Units are available with the following piping options:

- Two-way water-regulating valve with 350 psi (2413 kPa) design pressure.
- Three-way water-regulating valve with 150 psi (1034 kPa) design pressure.
- Three-way water-regulating valve with 350 psi (2413 kPa) design pressure.

2.3 Ship Loose Accessories—Field-Installed

The **Condensate Pump** is field-mounted inside the unit and wired to the unit power block or field-mounted outside the unit with power from unit or external power supply. Pump is complete with integral float switch, discharge check valve, pump, motor assembly and reservoir. A secondary float can be field-wired to shut down the unit upon high condensate level.

The **Canister Humidifier Kit** may be field-installed to customize cooling-only or reheat-only units. The kit includes full installation instructions and is added to the evaporator unit before it is mounted on its wall or floor location.

A **Remote Temperature and Humidity Sensor** package includes sensors in an attractive case with 30 ft (9 m) of cable. Can be wall- or duct-mounted. Remote sensors must be used when the wall box is not located in the space to be conditioned.

NOTE: Installing the remote sensors disables the sensors included in the wall box.

The **277-V Step-Down Transformer** is available for units that need 277-1-60 input power; one each for evaporator section and remote-condensing section (37.5 A max. each). Use one 37.5 A transformer for 1.5- or 2-ton self-contained water/glycol systems; use 50 A transformer for 3-ton self-contained water/glycol systems. Epoxy-encapsulated, transformer is suitable for either indoor or outdoor service.

2.3.1 Remote Monitoring, Autochangeover, and Leak Detection Equipment

The **Vertiv™ Liebert® IS-UNITY-DP**—provides full building-management system (BMS) access via BACnet/Modbus IP and BACnet/Modbus 485. Card provides access and supports SNMP v1/v2c/v3 & Vertiv™ Liebert® Nform. The wall-mount kit for field installation includes the Liebert® IS-UNITY-DP card, power/communication interface card, painted enclosure, 120-V wall outlet transformer with 6-ft (2-m) low-voltage power wire, and full instructions. Field-supplied wiring for communication to the Liebert® DataMate and to other systems is required to access features.

The **Vertiv™ Liebert® RCM4** is a four-point, normally-open, dry-contact monitoring panel. One Form-C, dry-contact common-alarm-relay output (rated at 24 VAC, 3 Amp) is provided. Four red LEDs illuminate on the respective alarm and the alarm buzzer is silenced by a front-panel switch. The Liebert® RCM4 requires a 24-VAC or 24-VDC power source. Power supply is not included.

The **Vertiv™ Liebert® Liqui-tect™ 410 Point Leak-Detection Sensor** detects the presence of conductive liquid using a pair of corrosion-resistant, gold-plated probes mounted in a painted, height-adjustable enclosure. Dual, Form-C, dry-contact common-alarm relays (rated at 24 VAC, 3 A) signal a leak detected as well as loss of power and cable fault. The Liebert® Liqui-tect™ 410 requires an external 24-VAC or 24-VDC power source.

Liebert® Liqui-tect™ 460 Zone Leak-Detection Kits include one LT460 sensor, a specified length of LT500-xxY cable (maximum length is 100 ft [30.5 m]) and a corresponding number of hold-down clips. The Liebert® LT460 requires an external 24-VAC, 0.12-A power source such as EXT-XFMR or XFMR24.

Vertiv™ Liebert® SiteScan™ is a monitoring solution that gives you decision-making power to effectively manage the equipment critical to your business.

Vertiv™ Liebert® SiteScan™ enables communication from Liebert® thermal-management and power units, as well as many other pieces of analog or digital equipment, to a front-end software package that provides real-time status and alarms so you can react quickly to changing situations.

Liebert® SiteScan™ is designed with flexibility for both small systems and large, complex systems such as those in computer rooms, telecommunications facilities, or industrial process-control rooms. Contact your local Vertiv representative for assistance with a Liebert® SiteScan™ system.

3 Nomenclature

This section describes the model-number configuration for Vertiv™ Liebert® DataMate units and components.

3.1 System Configurations

The following figures show the available capacity and cooling options for the Liebert® DateMate.

Figure 3.1 Air Cooled Units

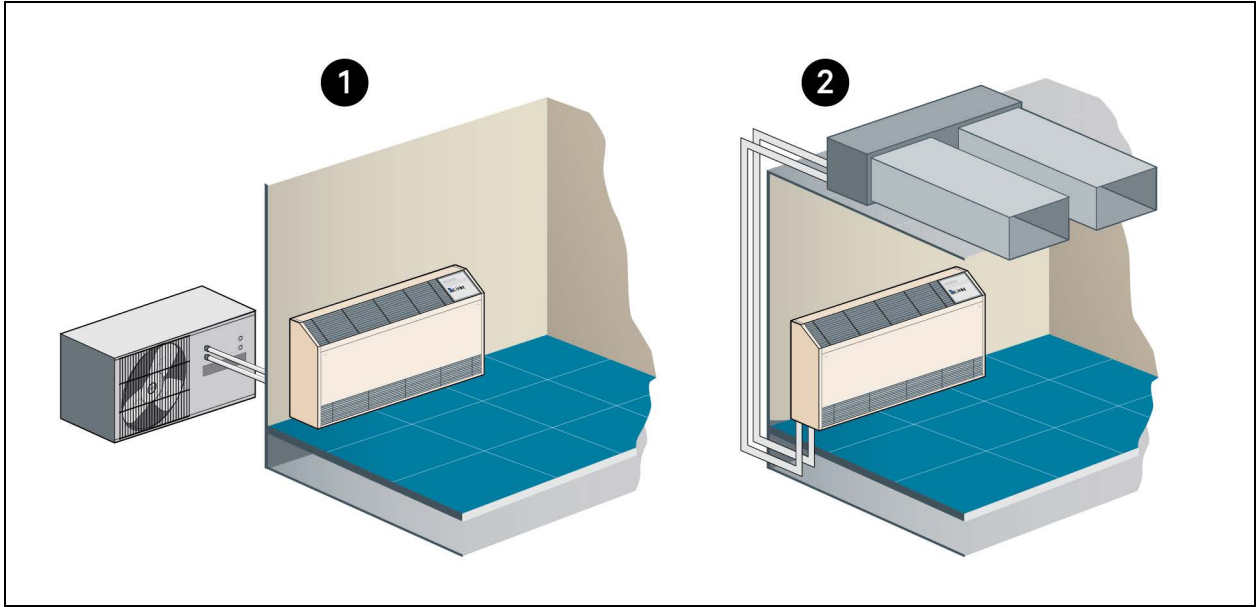

Item	Description
1	Air cooled with outdoor condensing unit suitable for installation on a roof or at ground level.
2	Air cooled with indoor condensing unit for applications where roof or other outdoor locations are impractical.

Figure 3.2 Water/Glycol Cooled Units

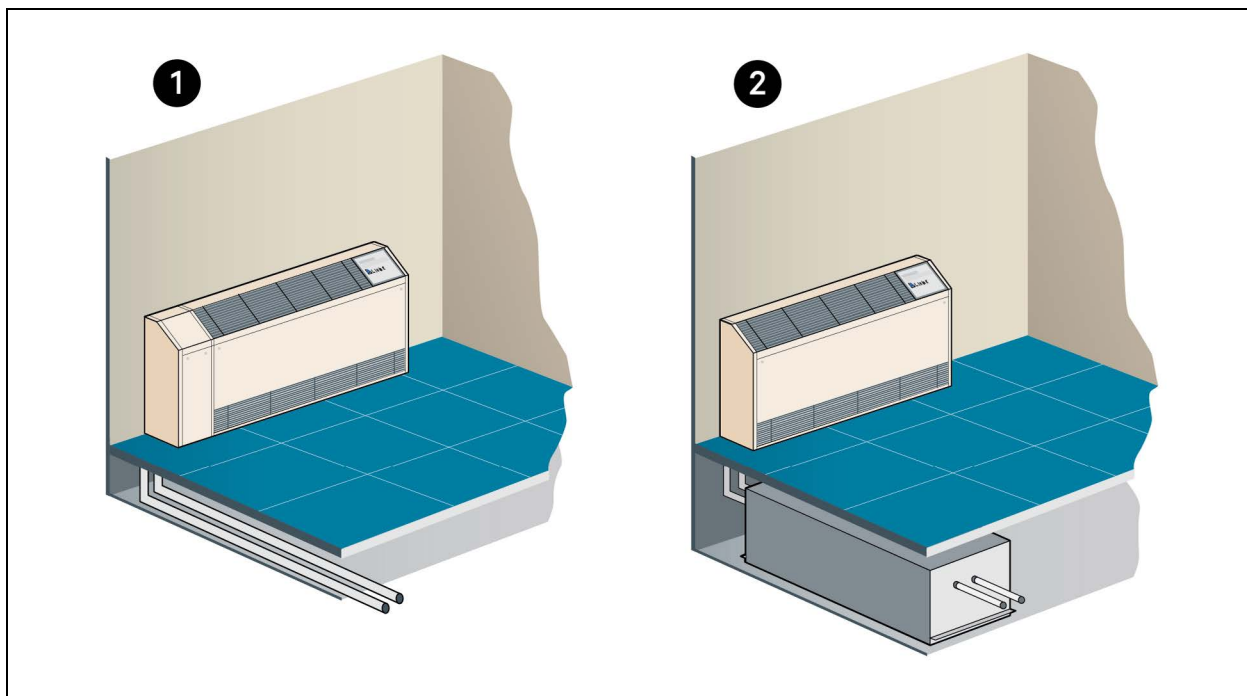

Item	Description
1	Water/Glycol cooled with close-coupled condensing unit conveniently needs only a single power-supply and water-supply connection installed.
2	Water/Glycol cooled with remote, indoor condensing unit that installs under the raised floor or above the dropped ceiling.

Figure 3.3 Chilled Water Units

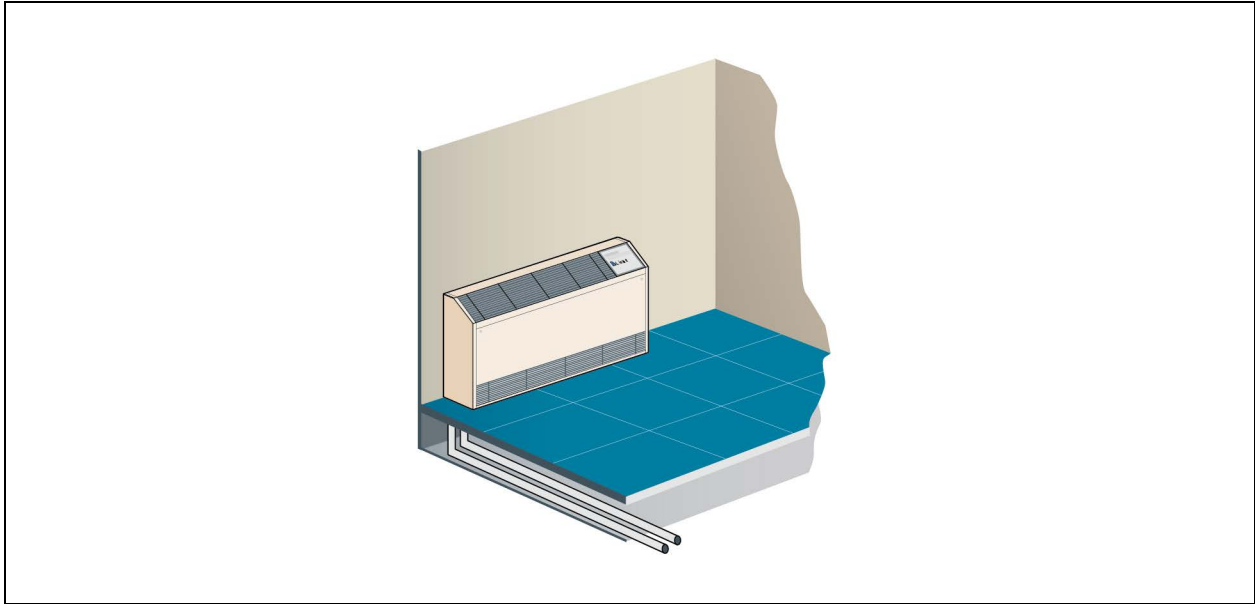

Item	Description
1	Chilled water cooled connects quickly and easily to a chilled water loop for ease of installation.

3.2 Nomenclature for Evaporator and Chilled Water Units

Nomenclature Digit Definitions for Evaporator and Chilled Water Units below describes each digit of the model number.

Table 3.1 Nomenclature Example

1	2	3	4	5	6	7	8	9	10	11
D	M	E	0	3	7	E	—	P	H	N

Table 3.2 Nomenclature Digit Definitions for Evaporator and Chilled Water Units

Digit	Description
Digits 1, 2, 3 = the base unit	DME = DataMate evaporator/chilled water cooling unit
Digits 4, 5, 6 = Nominal Capacity, kBtuh	
Digit 7, 8 = Cooling type	C -- = Chilled water cooled E -- = Evaporator
Digit 9 = Supply power	P = 208/230 V/1 ph/60 Hz W = 200/220 V /1 ph/50 Hz
Digit 10 = Reheat and Humidification	0 = Reheat only C = Cooling only H = Reheat and Humidifier
Digit 11 = Refrigerant/Revision	N = R-407C, field-supplied, field-charged (evaporator) 7 = Revision (chilled water)

3.3 Nomenclature for Condensing units

This section describes the model-number configuration for Vertiv™ Liebert® DataMate condensing units.

3.3.1 Outdoor Prop Fan Condensing Units for Air Cooled Systems

[Nomenclature Digit Definitions for Outdoor, Prop Fan Condensing Units](#) below describes each digit of the model number.

Table 3.3 Prop Fan Condensing Unit Nomenclature Example

1	2	3	4	5	6	7	8	9	10	11
P	F	H	0	3	7	A	—	P	L	N

Table 3.4 Nomenclature Digit Definitions for Outdoor, Prop Fan Condensing Units

Digit	Description
Digits 1 to 3 = the base unit	PFH = Prop fan condensing unit with hot-gas bypass
Digit 4 = Sound level	0 = Standard Z = Liebert® Quiet-Line
Digit 5 and 6 = Nominal Capacity, kBtuh	
Digit 7 = Cooling type	A = Air cooled
Digit 8 = Coil type	— = Standard coil C = Coated coil (epoxy with UV topcoat)
Digit 9 = Supply power	A = 460 V / 3 ph / 60 Hz B = 575 V / 3 ph / 60 Hz M = 380/415 V / 3 ph / 50 Hz P = 208/230 V / 1 ph / 60 Hz S = 220 V / 1 ph / 50 Hz Y = 208/230 V / 3 ph / 60 Hz
Digit 10 = Ambient rating/Control	L = 95°F Ambient, Liebert® Lee-Temp H = 105°F Ambient, Liebert® Lee-Temp
Digit 11 = Refrigerant	N = R-407C field-charged

3.3.2 Indoor Condensing Units for Air Cooled Systems

Nomenclature Digit Definitions for Indoor, Air Cooled Condensing Units below describes each digit of the model number.

Table 3.5 Indoor, Air Cooled Condensing Unit Nomenclature Example

1	2	3	4	5	6	7	8	9	10
M	C	D	3	6	A	L	A	H	N

Table 3.6 Nomenclature Digit Definitions for Indoor, Air Cooled Condensing Units

Digit	Description
Digits 1 to 2 = the base unit	MC = Mini-Mate2 style condensing unit
Digit 3 = Disconnect	D = Disconnect switch
Digit 4 and 5 = Nominal Capacity	24 = 24 kBtuh, 2-ton, 60 Hz 35 = 35 kBtuh, 3-ton, 50 Hz 36 = 36 kBtuh, 3-ton, 60 Hz
Digit 6 = Cooling type	A = Air cooled
Digit 7 = Head-pressure control	L = Liebert® Lee-Temp Receiver
Digit 8 = Supply power	A = 460 V/3 ph/60 Hz M = 380/415 V/3 ph/50 Hz P = 208/230 V/1 ph/60 Hz S = 220 V/1 ph/50 Hz X = 277 V/1 ph/50 Hz Y = 208/230 V/3 ph/60 Hz
Digit 9 = Hot-gas bypass	H = Hot-gas bypass
Digit 10 = Refrigerant	N = R-407C field-charged

3.3.3 Close-coupled Condensing Unit for Water/Glycol Cooled Systems

Nomenclature Digit Definitions for Close-coupled Water/Glycol Units below describes each digit of the model number.

Table 3.7 Close-coupled Water/Glycol Condensing Unit Nomenclature Example

1	2	3	4	5	6	7	8	9	10	11
D	M	C	0	4	0	W	G	P	0	N

Table 3.8 Nomenclature Digit Definitions for Close-coupled Water/Glycol Units

Digit	Description
Digits 1, 2, 3 = the base unit	DMC = DataMate condensing unit
Digits 4, 5, 6 = Nominal Capacity, kBtuh	
Digit 7, 8 = Cooling type	WG = Water/Glycol cooled
Digit 9 = Supply power	P = 208/230 V / 1 ph / 60 Hz
Digits 10, 11 = Refrigerant	ON = R-407C, field-supplied, field-charged

3.3.4 Remote, Indoor Water/Glycol Cooled Condensing Units

Nomenclature Digit Definitions for Indoor, Water/Glycol Cooled Condensing Units below describes each digit of the model number.

Table 3.9 Remote, Indoor Water/Glycol Condensing Unit Nomenclature Example

1	2	3	4	5	6	7	8	9	10
M	C	D	3	8	W	2	A	H	N

Table 3.10 Nomenclature Digit Definitions for Indoor, Water/Glycol Cooled Condensing Units

Digit	Description
Digits 1 to 2 = the base unit	MC = Mini-Mate2-style condensing unit
Digit 3 = Disconnect	D = Disconnect switch
Digit 4 and 5 = Nominal Capacity, kBtuh	
Digit 6 = Cooling type	W = Water/Glycol cooled
Digit 7 = Head-pressure control	2 = 2-way standard-pressure fluid-regulating valve 3 = 3-way standard-pressure fluid-regulating valve D = 2-way high-pressure fluid-regulating valve T = 3-way high-pressure fluid-regulating valve
Digit 8 = Supply power	A = 460 V/3 ph/60 Hz M = 380/415 V/3 ph/50 Hz P = 208/230 V/1 ph/60 Hz S = 220 V/1 ph/50 Hz X = 277 V/1 ph/50 Hz Y = 208/230 V/3 ph/60 Hz
Digit 9 = Hot-gas bypass	H = Hot-gas bypass
Digit 10 = Refrigerant	N = R-407C field-charged

4 System Data

4.1 Air Cooled Systems—Capacity and Performance Data

Table 4.1 Air Cooled Data, 60-Hz

Evaporator Model		DME020E	DME027E		DME037E	
Condensing Unit Type		PFH - Outdoor	PFH - Outdoor	MCD - Indoor	PFH - Outdoor	MCD - Indoor
DX Evaporator- Net Capacity Data - kW (Btuh) @ High Speed CFM						
80°F DB, 62.8°F WB (26.7°C DB, 17.1°C WB) 38 %RH	Total	5.50 (18,800)	7.20 (24,500)	6.90 (23,600)	10.25 (35,000)	9.70 (33,100)
	Sensible	5.50 (18,800)	7.20 (24,500)	6.90 (23,600)	9.95 (33,900)	9.60 (32,800)
75°F DB, 61°F WB (23.9°C DB, 16.1°C WB) 45 %RH	Total	5.10 (17,400)	6.70 (22,800)	6.45 (22,000)	9.80 (33,500)	9.25 (31,600)
	Sensible	5.05 (17,200)	6.65 (22,700)	6.40 (21,900)	8.90 (30,300)	8.60 (29,400)
72°F DB, 60°F WB (22.2°C DB, 15.5°C WB) 50 %RH	Total	4.90 (16,700)	6.40 (21,900)	6.20 (21,100)	9.60 (32,700)	9.05 (30,900)
	Sensible	4.70 (16,000)	6.20 (21,100)	6.05 (20,600)	8.20 (28,000)	7.95 (27,100)
Fan Data - Evaporator						
CFM (CMH) - High Speed		870 (1478)	1230 (2090)		1320 (2243)	
CFM (CMH) - Low Speed		750 (1274)	1050 (1784)		1175(1996)	
Fan Motor hp (W)		0.16 (120)	0.20 (150)*		0.27 (200)**	
Evaporator Coil - Copper Tube/Aluminum Fin						
Face Area ft ² (m ²)		2.44 (0.23)	3.92 (0.36)		3.92 (0.36)	
Coil Rows		4	3		4	
Max Face Velocity-fpm (m/s)		356 (1.8)	313 (1.6)		336 (1.7)	
Unit Refrigerant Charge, oz. (kg)		4 (0.11)	5 (0.14)		6.5 (0.18)	
Unit Operating Weight, lb. (kg)		230 (104)	330 (150)		365 (165)	
Electric Reheat Capacities (Includes Fan Motor)-kW (Btuh)						
Input Voltage 230-1-60		2.7 (9215)	5.3 (18,080)		5.5 (18,765)	
Humidifier Data - Steam Generator Type						
Steam capacity - lb/hr (kg/hr)		3 (1.4)	3 (1.4)		3 (1.4)	
Electrical Input Power - kW		1	1		1	
Evaporator Connection Sizes						
Liquid line Diameter, O.D. Cu		3/8"	3/8"		3/8"	
Suction Line Diameter, O.D. Cu		5/8"	7/8"		7/8"	
Humidifier Supply, OD Cu Compression Fitting		1/4"	1/4"		1/4"	
Humidifier Drain, Barb Fitting		1/2"	1/2"		1/2"	

Table 4.1 Air Cooled Data, 60-Hz (continued)

Evaporator Model	DME020E	DME027E		DME037E	
Condensing Unit Type	PFH - Outdoor	PFH - Outdoor	MCD - Indoor	PFH - Outdoor	MCD - Indoor
Evaporator Drain, Barb Fitting	3/4"	3/4"		3/4"	
Filter	Washable Polypropylene/Aluminum, MERV4				
Condensing Unit Model Number	PFH020A-_LN	PFH027A-_LN	MCD24AL_HN	PFH037A-_LN	MCD36AL_HN
Condensing Unit Rating Conditions	95°F (35°C) Ambient				
Coil Face Area ft ² (m ²)	4.1 (0.38)	4.1 (0.38)	4.6 (0.43)	7.7 (0.72)	4.6 (0.43)
Rows of Coil	2	2	4	2	4
CFM (CMH)	2200 (3738)	2200 (3738)	1000 (1699)	3000 (5097)	1430 (2490)
Motor, hp (W)	0.20 (149)	0.20 (149)	0.33 (246)	0.20 (149)	0.5 (373)
External Static Pressure, in wg. (mm)	N/A	N/A	0.50 (13)	N/A	0.50 (13)
Condensing Unit Refrigerant Charge, oz. (kg)	134 (3.8)	134 (3.8)	134 (3.8)	213 (6.0)	213 (6.0)
Unit Operating Weight, lb. (kg)	200 (91)	200 (91)	449 (204)	241 (109)	449 (204)
Condensing-unit Connection Sizes					
Liquid line Diameter, O.D. Cu	3/8"	3/8"	3/8"	3/8"	3/8"
Suction Line Diameter, O.D. Cu	5/8"	5/8"	5/8"	3/4"	7/8"
The net capacity data has fan motor heat factored in for all ratings and the entering air conditions of 75°F (23.9 °C), 45%RH, is the standard rating condition for ASHRAE 127-2007. All capacities are nominal values; actual performance will be ± 5%.					
*DME027 has two motors - 0.08 & 0.12 HP					
**DME037 has two motors - 0.11 & 0.16 HP					

Table 4.2 Air Cooled Data, 50-Hz

Evaporator Model	DME037E		
Condensing Unit Type	PFH - Outdoor	MCD - Indoor	
DX Evaporator- Net Capacity Data - kW (Btuh) @ High Speed CFM			
80°F DB, 62.8°F WB (26.7°C DB, 17.1°C WB) 38 %RH	Total	10.60 (36,200)	9.55 (32,600)
	Sensible	9.40 (32,100)	8.90 (30,400)
75°F DB, 61°F WB (23.9°C DB, 16.1°C WB) 45 %RH	Total	10.25 (34,900)	9.10 (31,400)
	Sensible	8.45 (28,800)	7.95 (27,100)
72°F DB, 60°F WB (22.2°C DB, 15.5°C WB) 50 %RH	Total	10.00 (34,100)	9.00 (30,700)
	Sensible	7.85 (26,700)	7.35 (25,100)

Table 4.2 Air Cooled Data, 50-Hz (continued)

Evaporator Model	DME037E	
Condensing Unit Type	PFH - Outdoor	MCD - Indoor
Fan Data - Evaporator		
CFM (CMH) - High Speed	1100 (1869)	
CFM (CMH) - Low Speed	980 (1665)	
Fan Motor HP (W)	0.27 (200)**	
Evaporator Coil - Copper Tube/Aluminum Fin		
Face Area ft ² (m ²)	3.92 (0.36)	
Coil Rows	4	
Max Face Velocity-fpm (m/s)	336 (1.7)	
Unit Refrigerant Charge, oz. (kg)	6.5 (0.18)	
Unit Operating Weight, lb. (kg)	365 (165)	
Electric Reheat Capacities (Includes Fan Motor)-kW (Btuh)		
Input Voltage 230-1-50	5.5 (18,765)	
Humidifier Data - Steam Generator Type		
Steam capacity - lb/hr (kg/hr)	3 (1.4)	
Electrical Input Power - kW	1	
Evaporator Connection Sizes		
Liquid line Diameter, O.D. Cu	3/8"	
Suction Line Diameter, O.D. Cu	7/8"	
Humidifier Supply, OD Cu Compression Fitting	1/4"	
Humidifier Drain, Barb Fitting	1/2"	
Evaporator Drain, Barb Fitting	3/4"	
Filter	Washable Polypropylene/Aluminum, MERV4	

Table 4.2 Air Cooled Data, 50-Hz (continued)

Evaporator Model	DME037E	
Condensing Unit Type	PFH - Outdoor	MCD - Indoor
Condensing Unit Model Number	PFH036A_LN	MCD35AL_HN
Condensing Unit Rating Conditions		
Coil Face Area ft ² (m ²)	7.7 (0.72)	4.6 (0.43)
Rows of Coil	2	4
CFM (CMH)	2500 (4248)	1430 (2430)
Motor, hp (W)	0.20 (149)	0.5 (373)
External Static Pressure, in wg. (mm)	N/A	0.50 (13)
Condensing Unit Refrigerant Charge, oz. (kg)	213 (6.0)	213 (6.0)
Unit Operating Weight, lb. (kg)	241 (109)	449 (204)
Condensing-unit Connection Sizes		
Liquid line Diameter, O.D. Cu	3/8"	3/8"
Suction Line Diameter, O.D. Cu	3/4"	7/8"
The net capacity data has fan motor heat factored in for all ratings and the entering air conditions of 75°F (23.9 °C), 45%RH, is the standard rating condition for ASHRAE 127-2007. All capacities are nominal values; actual performance will be ± 5%.		
**DME037 has two motors - 0.11 & 0.16 HP		

4.2 Water/Glycol Cooled Systems—Capacity and Performance Data

Table 4.3 Water Cooled and Glycol Cooled Units, 60-Hz

Evaporator Model		DME020E		DME027E		DME037E	
Condensing Unit Type		Water Cooled	Glycol Cooled	Water Cooled	Glycol Cooled	Water Cooled	Glycol Cooled
DX Evaporator- Net Capacity Data - kW (Btuh) @ High Speed CFM							
80°F DB, 62.8°F WB (26.7°C DB, 17.1°C WB) 38 %RH	Total	5.90 (20,100)	5.15 (17,600)	7.95 (27,200)	6.75 (23,000)	11.4 (38,900)	9.65 (32,900)
	Sensible	5.80 (19,800)	5.15 (17,600)	7.90 (27,000)	6.75 (23,000)	10.3 (35,300)	9.40 (32,100)
75°F DB, 61°F WB (23.9°C DB, 16.1°C WB) 45 %RH	Total	5.50 (18,800)	4.80 (16,300)	7.55 (25,800)	6.25 (21,300)	11.0 (37,400)	9.20 (31,400)
	Sensible	5.15 (17,600)	4.75 (16,200)	7.10 (24,200)	6.25 (21,300)	9.20 (31,400)	8.35 (28,500)
72°F DB, 60°F WB (22.2°C DB, 15.5°C WB) 50 %RH	Total	5.35 (18,100)	4.60 (15,700)	7.35 (25,000)	6.00 (20,500)	10.7 (36,600)	8.95 (30,600)
	Sensible	4.75 (16,200)	4.35 (14,900)	6.55 (22,300)	5.85 (19,900)	8.55 (29,100)	7.70 (26,300)
Fan Data - Evaporator							
CFM (CMH) - High Speed		870 (1478)		1230 (2090)		1320 (2243)	
CFM (CMH) - Low Speed		750 (1274)		1050 (1784)		1175(1996)	
Fan Motor hp (W)		0.16 (120)		0.20 (150)*		0.27 (200)**	
Evaporator Coil - Copper Tube/Aluminum Fin							
Face Area ft ² (m ²)		2.44 (0.23)		3.92 (0.36)		3.92 (0.36)	
Coil Rows		4		3		4	
Max Face Velocity-fpm (m/s)		356 (1.8)		313 (1.6)		336 (1.7)	
Unit Refrigerant Charge, oz. (kg)		4 (0.11)		5 (0.14)		6.5 (0.18)	
Unit Operating Weight, lb. (kg)		230 (104)		330 (150)		365 (165)	
Electric Reheat Capacities (Includes Fan Motor)-kW (Btuh)							
Input Voltage 230-1-60		2.7 (9215)		5.3 (18,080)		5.5 (18,765)	
Humidifier Data - Steam Generator Type							
Steam capacity - lb/hr (kg/hr)		3 (1.4)		3 (1.4)		3 (1.4)	
Electrical Input Power - kW		1		1		1	
Evaporator Connection Sizes							
Liquid line Diameter, O.D. Cu		3/8"		3/8"		3/8"	
Suction Line Diameter, O.D. Cu		5/8"		7/8"		7/8"	
Humidifier Supply		1/4" OD Copper Compression Fitting					

Table 4.3 Water Cooled and Glycol Cooled Units, 60-Hz (continued)

Evaporator Model	DME020E		DME027E		DME037E	
	Water Cooled	Glycol Cooled	Water Cooled	Glycol Cooled	Water Cooled	Glycol Cooled
Humidifier Drain, Barb Fitting	1/2"		1/2"		1/2"	
Evaporator Drain, Barb Fitting	3/4"		3/4"		3/4"	
Filter	Washable Polypropylene/Aluminum, MERV4					
Close-Coupled DMC Condensing Unit Model	DMC022WG		DMC029WG		DMC040WG	
Condenser Fluid Requirements, °F (°C)	85 (29.4) EWT	110 (43.3) EGT -40% PG	85 (29.4) EWT	110 (43.3) EGT - 40% PG	85 (29.4) EWT	110 (43.3) EGT - 40% PG
THR - kW (Btuh) @ 75F/45%RH	7.30 (24,900)	7.10 (24,200)	9.60 (32,700)	9.10 (31,000)	13.9 (47,400)	13.2 (45,100)
Flow Rate - GPM (l/m)	4.0 (15.2)	5.9 (22.4)	4.6 (17.4)	6.9 (26.2)	7.8 (29.6)	9.1 (34.5)
Pressure Drop - ft. of H2O (kPa)	7.0 (20.9)	17.0 (50.8)	4.4 (13.2)	10.4 (31.1)	8.4 (25.1)	13.6 (40.7)
Water Cooled Condensing Temperature, °F (°C)	105 (40.6)	N/A	105 (40.6)	N/A	105 (40.6)	N/A
DMC Condensing-unit Connection Sizes						
Water/Glycol Connection Sizes, in. O.D. Cu	5/8		7/8			
Liquid line Diameter, O.D. Cu	3/8"		3/8"		3/8"	
Suction Line Diameter, O.D. Cu	5/8"		7/8"		7/8"	
Unit Volume - Gal (l)	0.25 (0.95)		0.40 (1.5)		0.50 (1.9)	
Unit Refrigerant Charge, oz. (kg)	47 (1.33)		59 (1.67)		61 (1.72)	
Unit Operating Weight, lb. (kg)	169 (77)		169 (77)		172 (78)	
Remote MCD Condensing Unit Model #	—		MCD26W		MCD38W	
Condenser Fluid Requirements, °F (°C)	N/A		85 (29.4) EWT	110 (43.3) EGT - 40% PG	85 (29.4) EWT	110 (43.3) EGT - 40% PG
THR - kW (Btuh) @ 75F/45%RH	—		9.60 (32,700)	9.10 (31,000)	13.9 (47,400)	13.2 (45,100)
Flow Rate - GPM (l/m)	—		7.7 (24.2)	8.9 (33.7)	6.5 (24.6)	12.1 (45.9)
Pressure Drop - ft. of H2O (kPa)	—		16.6 (49.6)	26.0 (77.7)	11.6 (34.7)	44.7 (133.7)
Water Cooled Condensing Temperature	—		105°F (40.6°C)	N/A	105°F (40.6°C)	N/A

Table 4.3 Water Cooled and Glycol Cooled Units, 60-Hz (continued)

Evaporator Model	DME020E		DME027E		DME037E	
	Water Cooled	Glycol Cooled	Water Cooled	Glycol Cooled	Water Cooled	Glycol Cooled
MCD Condensing-unit Connection Sizes						
MCD Water/Glycol Connection Sizes, in. O.D. Cu	—		7/8		7/8	
Liquid line Diameter, O.D. Cu	—		3/8"		3/8"	
Suction Line Diameter, O.D. Cu	—		5/8"		7/8"	
Unit Volume - Gal (l)	—		1.2 (4.5)		1.2 (4.5)	
Unit Refrigerant Charge, oz. (kg)	—		41 (1.16)		54 (1.54)	
Unit Operating Weight, lb. (kg)	—		175 (79)		220 (100)	
The net capacity data has fan motor heat factored in for all ratings and the entering air conditions of 75°F (23.9 °C), 45%RH, is the standard rating condition for ASHRAE 127-2007. All capacities are nominal values; actual performance will be ± 5%. *DME027 has two motors - 0.08 & 0.12 HP; ** DME037 has two motors - 0.11 & 0.16 HP						

Table 4.4 Water Cooled and Glycol Cooled Units, 50-Hz

Evaporator Model	DME037E	
	Water Cooled	Glycol Cooled
DX Evaporator-Net Capacity Data - kW (Btuh) @ High Speed CFM		
80°F DB, 62.8°F WB (26.7°C DB, 17.1°C WB) 38 %RH	Total	11.3 (38,700)
	Sensible	9.55 (32,600)
75°F DB, 61°F WB (23.9°C DB, 16.1°C WB) 45 %RH	Total	11.0 (37,400)
	Sensible	8.55 (29,200)
72°F DB, 60°F WB (22.2°C DB, 15.5°C WB) 50 %RH	Total	10.7 (36,600)
	Sensible	7.95 (27,200)
Fan Data - Evaporator		
CFM (CMH) - High Speed	1100 (1869)	
CFM (CMH) - Low Speed	980 (1665)	
Fan Motor HP (W)	0.27 (200)**	
Evaporator Coil - Copper Tube/Aluminum Fin		
Face Area ft ² (m ²)	3.92 (0.36)	
Coil Rows	4	
Max Face Velocity-fpm (m/s)	336 (1.7)	
Unit Refrigerant Charge, oz. (kg)	6.5 (0.18)	

Table 4.4 Water Cooled and Glycol Cooled Units, 50-Hz (continued)

Evaporator Model	DME037E	
Condensing Unit Type	Water Cooled	Glycol Cooled
Unit Operating Weight, lb. (kg)	365 (165)	
Electric Reheat Capacities (Includes Fan Motor)-kW (Btu/H)		
Input Voltage 230-1-50	5.5 (18,765)	
Humidifier Data - Steam Generator Type		
Steam capacity - lb/hr (kg/hr)	3 (1.4)	
Electrical Input Power - kW	1	
Evaporator Connection Sizes		
Liquid line Diameter, O.D. Cu	3/8"	
Suction Line Diameter, O.D. Cu	7/8"	
Humidifier Supply	1/4" OD Cu Compression Fitting	
Humidifier Drain, Barb Fitting	1/2"	
Evaporator Drain, Barb Fitting	3/4"	
Filter	Washable Polypropylene/Aluminum, MERV4	
Remote MCD Condensing Unit Model #		
MCD37W		
Condenser Fluid Requirements	85°F (29.4°C)	110°F (43.3°C)
	EWT	EGT - 40% PG
THR - kW (Btuh) @ 75F/45%RH	13.7 (46,700)	12.9 (44,000)
Flow Rate - GPM (l/m)	6.4 (24.3)	13.5 (51.2)
Pressure Drop - ft. of H2O (kPa)	11.7 (35.0)	55.8 (166.8)
Water Cooled Condensing Temperature	105 °F (40.6 °C)	N/A
MCD Condensing-unit Connection Sizes		
Water/Glycol Connection Sizes, in. O.D. Cu	7/8	
Liquid line Diameter, O.D. Cu	3/8"	
Suction Line Diameter, O.D. Cu	7/8"	
Unit Volume - Gal (l)	1.2 (4.5)	
Unit Refrigerant Charge, oz. (kg)	54 (1.54)	
Unit Operating Weight, lb. (kg)	220 (100)	
The net capacity data has fan motor heat factored in for all ratings and the entering air conditions of 75°F (23.9 °C), 45%RH, is the standard rating condition for ASHRAE 127-2007. All capacities are nominal values; actual performance will be ± 5%.		
**DME037 has two motors - 0.11 & 0.16 hp		

4.3 Chilled Water Systems—Capacity and Performance Data

Table 4.5 Chilled Water Data, 50/60Hz

Model Number	DME044C		
	208/230-1-60	200/220-1-50	
Net Capacity Data - kW (Btuh) based on 45°F (7.2°C) EWT & 10°F (5.6°C) temperature rise			
80°F DB, 62.8°F WB (26.7°C DB, 17.1°C WB) 38 %RH	Total	10.5 (35,800)	9.05 (30,900)
	Sensible	9.65 (33,000)	8.25 (28,200)
	Flow Rate, GPM (l/m)	7.3 (27.7)	6.3 (23.9)
	Pressure Drop, ft. water (kPa)	12.5 (37.4)	9.7 (29.0)
75°F DB, 61°F WB (23.9°C DB, 16.1°C WB) 45 %RH	Total	8.75 (29,800)	7.55 (25,800)
	Sensible	7.95 (27,100)	6.85 (23,300)
	Flow Rate, GPM (l/m)	6.1 (23.1)	5.3 (20.1)
	Pressure Drop, ft. water (kPa)	9.1 (27.2)	7.0 (20.9)
72°F DB, 60°F WB (22.2°C DB, 15.5°C WB) 50 %RH	Total	7.65 (26,100)	6.6 (22,600)
	Sensible	6.90 (23,500)	5.9 (20,200)
	Flow Rate, GPM (l/m)	5.3 (20.1)	4.6 (17.4)
	Pressure Drop, ft. water (kPa)	7.2 (21.5)	5.6 (16.7)
Fan Data - Evaporator			
CFM (CMH) - High Speed	1320 (2243)	1100 (1869)	
CFM (CMH) - Low Speed	1175 (1996)	980 (1665)	
Fan Motor, hp (W)	0.27 (200)**	0.27 (200)**	
CW Coil - Copper Tube/Aluminum Fin			
Face Area, ft ² (m ²)	3.92 (0.36)		
Coil Rows	3		
Max Face Velocity-fpm (m/s)	336 (1.7)	281 (1.4)	
Electric Reheat Capacity (Includes Fan Motor), kW (Btuh)			
Input Voltage 230-1-60/50	5.5 (18,765)		
Humidifier Data - Steam Generator Type			
Steam capacity, lb/hr (kg/hr)	3 (1.4)		
Electrical Input Power, kW	1		
Unit Connection Sizes			
CW supply and return connections, in. OD CU	7/8		
Humidifier Supply	1/4" OD Copper Compression Fitting		
Humidifier Drain, Barb Fitting	1/2"		

Table 4.5 Chilled Water Data, 50/60Hz (continued)

Model Number	DME044C	
	208/230-1-60	200/220-1-50
Evaporator/Condensate Drain, Barb Fitting	3/4"	
Unit Internal Fluid Volume, gal (l)	1.0 (3.8)	
Filter	Washable Polypropylene/Aluminum, MERV4	
Unit Operating Weight, lb. (kg.)	365 (165)	
Unit Valve Types	On/Off Slow Close, 2-Way	
Valve Size	3/4"	
Valve Cv	7	
Max. Water Static Operating Pressure, psi (kPa)	300 (2068)	
Close-Off Pressure, psi (kPa)	60 (414)	
<p>The net capacity data has fan motor heat factored in for all ratings and the entering air conditions of 75°F (23.9 °C), 45%RH, is the standard rating condition for ASHRAE 127-2007. All capacities are nominal values; actual performance will be ± 5%.</p> <p>** DME044C has two motors - 0.11 & 0.16 HP</p>		

Table 4.6 Chilled Water Capacity Correction Factors Based on 10°F (5.6°C) Water Rise

EWT	72°F (22.2°C) 50%		75°F (23.9°C) 45%RH	
	Total	Sensible	Total	Sensible
42°F (5.6°C)	1.27	1.14	1.23	1.11
43°F (6.1°C)	1.17	1.09	1.15	1.07
44°F (6.7°C)	1.08	1.04	1.07	1.04
45°F (7.2°C)	1.00	1.00	1.00	1.00
46°F (7.8°C)	0.93	0.96	0.94	0.96
47°F (8.3°C)	0.86	0.92	0.88	0.93
48°F (8.9°C)	0.79	0.88	0.82	0.89
49°F (9.4°C)	0.74	0.83	0.77	0.85

4.4 Planning Dimensions

The unit dimensions are described in the submittal documents included in the [Submittal Drawings](#) on page 39 .

The following table lists the relevant documents by number and title.

Table 4.7 Dimension Planning Drawings

Document Number	Title
Evaporators/Chilled Water Units	
DPN000262	Cabinet Dimensions, Evaporator/Chilled water Unit
DPN000269	Cabinet Dimensions, Water/Glycol Condensing Unit - Close-coupled
Outdoor Condensing Units	
DPN004418	Cabinet Dimensions, Prop Fan Condensing Unit with horizontal air discharge
DPN003094	Optional Anchorage Plan, Prop Fan Condensing Unit with horizontal air discharge
Indoor Condensing Units	
DPN004420	Cabinet Dimensions, Air cooled units
DPN004421	Cabinet Dimensions, Water/Glycol cooled units

This page intentionally left blank

5 Electrical Data

5.1 Evaporators and Chilled Water Units Electrical Data

Table 5.1 Split-system Evaporator or Self-contained Chilled Water units, 50/60-Hz

Base Evaporator/ Chilled Water	DME020E	DME027E	DME037E DME044C	DME020E	DME027E	DME037E DME044C
	208/230V-1ph-60Hz			200/220V-1-50		
Cooling Only						
FLA	1.4	1.5	2.2	1.4	1.5	2.2
WSA	1.8	1.9	2.8	—	—	—
OPD	15	15	15	—	—	—
With Reheat						
FLA	11.8	22.3	23.0	11.8	22.3	23.0
WSA	14.8	27.9	28.8	—	—	—
OPD	15	30	30	—	—	—
With Reheat & Humidifier						
FLA	18.8	29.3	30.0	18.8	29.3	30.0
WSA	23.5	36.6	37.5	—	—	—
OPD	25	40	40	—	—	—

5.2 Close-coupled Water/Glycol Units Electrical Data

Table 5.2 Evaporator with Close-coupled Condensing Unit with single power feed, 60-Hz

Evaporator Model/ Condensing Model	DME020E/ DMC022WG	DME027E/ DMC029WG	DME037E/ DMC029WG
Volt-Ph-Hz	208/230-1-60	208/230-1-60	208/230-1-60
Cooling Only			
FLA	12.1	13.5	19.3
WSA	14.8	16.5	23.6
OPD	25	25	40
With Reheat or With Reheat & Humidifier			
FLA	22.5	34.3	40.1
WSA	27.8	42.5	49.6
OPD	35	45	60

5.3 Indoor, Remote Condensing Units Electrical Data

Table 5.3 Indoor, Remote Air and Water/Glycol Condensing Unit Electrical Data, 60-Hz and 50Hz

	60 Hz				50 Hz	
	208/230-1ph-60Hz	277-1ph-60Hz	208/230-3ph-60Hz	460-3ph-60Hz	220-1ph-50Hz	380/415-3ph-50Hz
Model	MCD24A	MCD24A	—	—	—	—
FLA	14.3	12.7	—	—	—	—
WSA	17.3	15.3	—	—	—	—
OPD	25	25	—	—	—	—
Model	MCD36A	MCD36A	MCD36A	MCD36A	MCD35A	MCD35A
FLA	20.8	16.6	15.7	7.8	20.1	7.8
WSA	25.1	20.2	18.7	9.4	—	—
OPD	40	30	30	15	—	—
Model	MCD26W	MCD26W	—	—	—	—
FLA	12.0	10.4	—	—	—	—
WSA	15.0	13.0	—	—	—	—
OPD	25	20	—	—	—	—
Model	MCD38W	MCD38W	MCD38W	MCD38W	MCD37W	MCD37W
FLA	17.1	14.3	12.0	6.4	17.1	6.4
WSA	21.4	17.9	15.0	8.0	—	—
OPD	35	30	25	15	—	—

5.4 Outdoor Condensing Units Electrical Data

Table 5.4 Outdoor Condensing Unit Electrical Data, 60-Hz

Standard 95°F (35°C) Propeller Fan Condensing Unit						
Model	PFH020A-PLN	PFH027A-PLN	PFH037A-PLN	PFH037A-YLN	PFH037A-ALN	PFH037A-BLN
Volt-Ph-Hz	208/230-1-60	208/230-1-60	208/230-1-60	208/230-3-60	460-3-60	575-3-60
FLA	12.1	13.4	18.5	13.4	7.1	5.8
WSA	14.8	16.4	22.8	16.4	8.7	7.0
OPD	25	25	35	25	15	15
High Ambient Propeller Fan Condensing Unit						
Model	N/A	PFH027A-PHN	PFH037A-PHN	PFH037A-YHN	PFH037A-AHN	PFH037A-BHN
Volt-Ph-Hz	N/A	208/230-1-60	208/230-1-60	208/230-3-60	460-3-60	575-3-60
FLA	N/A	15.4	20.5	15.4	8.1	5.8
WSA	N/A	18.4	24.8	18.4	9.7	7.0
OPD	N/A	30	40	30	15	15
Liebert® Quiet-Line Propeller Fan Condensing Unit						
Model	N/A	PFHZ27A-PLN	PFHZ37A-PLN	PFHZ37A-YLN	PFHZ37A-ALN	—
Volt-Ph-Hz	N/A	208/230-1-60	208/230-1-60	208/230-3-60	460-3-60	—
FLA	N/A	12.9	18.0	12.9	7.1	—
WSA	N/A	15.9	22.3	15.9	8.7	—
OPD	N/A	25	40	30	15	—

Table 5.5 Outdoor Condensing Unit Electrical Data, 50-Hz

Standard 95°F (35°C) Propeller Fan Condensing Unit		
Model	PFH036A-SLN	PFH036A-MLN
Volt-Ph-Hz	220-1-50	380/415-3-50
FLA	18.4	7.0
High Ambient Propeller Fan Condensing Unit		
Model	PFH036A-SHN	PFH036A-MHN
Volt-Ph-Hz	220-1-50	380/415-3-50
FLA	20.5	8.1
Liebert® Quiet-Line Propeller Fan Condensing Unit		
Model	PFHZ36A-SLN	PFHZ36A-MLN
Volt-Ph-Hz	220-1-50	380/415-3-50
FLA	18.0	6.9

5.5 Electrical Field Connections

Electrical service must conform to national and local electrical codes.

The electrical connections are described in the submittal documents included in the [Submittal Drawings](#) on page 39 .

The following table lists the relevant documents by number and title.

Table 5.6 Electrical Field Connection Drawings

Document Number	Title
Evaporator and Chilled Water Units	
DPN000264	Electrical Connections, Air cooled and Chilled water units
DPN000271	Electrical Connections, Water/Glycol cooled units
DPN004912	Arrangement and Dimensions, Liebert® IS-UNITY-DP for BMS Communication
DPN004854	Electrical Connections, Liebert® IS-UNITY-DP for BMS Communication
Split-system Indoor Condensing Units	
DPN000207	Electrical Connections, Air cooled units
DPN000209	Electrical Connections, Water/Glycol cooled units

6 Piping

The pipe connection locations, piping general arrangement and schematics are described in the submittal documents included in the [Submittal Drawings](#) on page 39 .

The following tables list the relevant documents by number and title.

Table 6.1 Piping General Arrangement Drawings

Document Number	Title
DPN004406	Piping, Air cooled models
DPN004405	Piping, Split-system Water/Glycol models
DPN004403	Piping, Close-coupled Water/Glycol and Chilled water models
DPN003822	Multiple Drycoolers and Cooling Units on Common Glycol Loop

Table 6.2 Piping Connection Drawings

Document Number	Title
Evaporator and Chilled Water Units	
DPN004306	Piping Connections, Evaporator and Chilled water units
Split-system Indoor Condensing Units	
DPN004420	Piping Connections, Air cooled condensing unit
DPN004421	Piping Connections, Remote Water/Glycol cooled condensing unit
DPN004309	Piping Connections, Close-coupled Water/Glycol cooled units
DPN004308	Piping Connections, Prop Fan Condensing Unit, Horizontal Discharge
Condensate Pump Connections	
DPN004306	Field-installed condensate pump connection

6.1 Refrigerant Charge Requirements

Table 6.3 R-407C Refrigerant Unit Charge

60 Hz	50 Hz	Charge R-407C, oz (kg)
DME020E	—	4 (0.11)
DME027E	—	5 (0.14)
DME037E	DME037E	6.5 (0.18)
MCD24AL_HN	—	134 (3.80)
MCD36AL_HN	MCD35AL_HN	213 (6.04)
MCD26W_HN	—	41 (1.16)
MCD38W_HN	MCD37W_HN	54 (1.54)

Table 6.3 R-407C Refrigerant Unit Charge (continued)

60 Hz	50 Hz	Charge R-407C, oz (kg)
DMC022WG	—	47 (1.33)
DMC029WG	—	59 (1.67)
DMC040WG	—	61 (1.72)
PFH020A-_LN	—	134 (3.80)
PFH027A-_LN	—	134 (3.80)
PFH027A-_HN	—	213 (6.04)
PFHZ27A-_LN	—	213 (6.04)
PFH037A-_LN	PFH036A-_LN	213 (6.04)
PFH037A-_HN	PFH036A-_HN	426 (12.08)
PFHZ37A-_LN	PFHZ36A-_LN	426 (12.08)

Table 6.4 Line Charges of R-407C Refrigerant Using Type-L Copper Tube

Line Size, OD, in.	Liquid Line, lb/100 ft (kg/30 m)	Suction Line, lb/100ft (kg/30 m)
3/8	3.6 (1.6)	—
1/2	6.7 (3.0)	0.2 (0.1)
5/8	10.8 (4.8)	0.3 (0.1)
3/4	16.1 (7.2)	0.4 (0.2)
7/8	22.3 (10.0)	0.5 (0.3)
1-1/8	38.0 (17.0)	0.9 (0.4)
1-3/8	57.9 (25.9)	1.4 (0.7)

Source: DPN003099 Rev. 1

6.1.1 Refrigerant-line Sizes and Equivalent Lengths

The following tables list information required to field-install the refrigerant piping for the system.

The pipe connection sizes for your equipment are included in the appropriate submittal documents included in the [Submittal Drawings](#) on page 39 .

Table 6.5 Recommended Refrigerant Line Sizes, O.D. cu by Equivalent Length

Equivalent Length, ft (m)	1.5-Ton		2-Ton		3-Ton	
	Suction	Liquid	Suction	Liquid	Suction	Liquid
50 (15)	5/8"	3/8"	7/8"	3/8"	7/8"	1/2"
75 (23)	7/8"	3/8"	7/8"	3/8"	7/8"	1/2"
100 (30)	7/8"	3/8"	7/8"	1/2"	1-1/8" ²	1/2"

Table 6.5 Recommended Refrigerant Line Sizes, O.D. cu by Equivalent Length (continued)

Equivalent Length, ft (m)	1.5-Ton		2-Ton		3-Ton	
	Suction	Liquid	Suction	Liquid	Suction	Liquid
125 (38)	7/8"	1/2"	7/8"	1/2"	1-1/8" ²	1/2"
150 (45)	7/8"	1/2"	7/8"	1/2"	1-1/8" ²	1/2"

1. Suction-line and liquid-line sizing based on < 3 psi pressure drop in each and horizontal suction line refrigerant velocities > 700 FPM (3.6 m/s).

2. Suction sizes should be reduced one pipe size for vertical riser sections to maintain suction-line velocity > 1000 FPM (5.1 m/s) for proper oil return.

Source: DPN000788 Rev. 13

Table 6.6 Equivalent Lengths for Various Pipe Fittings, ft (m)

Copper Pipe OD, in.	90 Degree Elbow Copper	90 Degree Elbow Cast	45 Degree Elbow	Tee	Gate Valve	Globe Valve	Angle Valve
1/2	0.8 (0.24)	1.3 (0.39)	0.4 (0.12)	2.5 (0.76)	0.26 (0.07)	7.0 (2.13)	4.0 (1.21)
5/8	0.9 (0.27)	1.4 (0.42)	0.5 (0.15)	2.5 (0.76)	0.28 (0.08)	9.5 (2.89)	5.0 (1.52)
3/4	1.0 (0.3)	1.5 (0.45)	0.6 (0.18)	2.5 (0.76)	0.3 (0.09)	12.0 (3.65)	6.5 (1.98)
7/8	1.45 (0.44)	1.8 (0.54)	0.8 (0.24)	3.6 (1.09)	0.36 (0.1)	17.2 (5.24)	9.5 (2.89)
1-1/8	1.85 (0.56)	2.2 (0.67)	1.0 (0.3)	4.6 (1.4)	0.48 (0.14)	22.5 (6.85)	12.0 (3.65)
1-3/8	2.4 (0.73)	2.9 (0.88)	1.3 (0.39)	6.4 (1.95)	0.65 (0.19)	32.0 (9.75)	16.0 (4.87)
1-5/8	2.9 (0.88)	3.5 (1.06)	1.6 (0.48)	7.2 (2.19)	0.72 (0.21)	36.0 (10.97)	19.5 (5.94)

Refrigerant trap = Four times equivalent length of pipe per this table

6.1.2 Piping when Condensing Unit is Above or Below Evaporator

Refer to [Pipe Length and Condensing Unit Elevation Relative to Evaporator](#) on the next page, for the maximum vertical rise/fall between condensing unit and evaporator.

When installing remote condensing units above the evaporator, trap the suction gas line at the evaporator as shown in [Refrigerant Piping Diagram when Condenser is Above or Below Evaporator](#) on the next page. This trap will retain refrigerant oil during the "Off" cycle. When the unit starts, oil in the trap is carried up the vertical riser and returns to the compressor. For rises over 25 ft (7.6 m), trap every 20 ft (6 m) or evenly divided.

When installing remote condensing units below the evaporator, trap the suction gas line with an inverted trap the height of the evaporator as shown [Refrigerant Piping Diagram when Condenser is Above or Below Evaporator](#) on the next page. This prevents refrigerant migration to the compressor during "Off" cycles. The maximum recommended vertical-level drop to condensing unit is 15 ft (4.6 m).

Table 6.7 Pipe Length and Condensing Unit Elevation Relative to Evaporator

Nominal System Size, ton	Maximum Equivalent Pipe Length, ft (m)	Maximum Condensing Unit Level Above Evaporator, ft (m)	Maximum Condensing Unit Level Below Evaporator, ft (m)
1.5 and 2	150 (45)	40 (12)	15 (4.6)
3	150 (45)	50 (15)	15 (4.6)

Maximum recommended total equivalent pipe length is 150 ft (46 m). Suction and liquid lines may require additional specialty items when vertical lines exceed 20 ft (6 m) and/or condensing unit installation is more than 15 ft (4.6 m) below the evaporator. Contact Vertiv™ Technical Support for assistance.

Figure 6.1 Refrigerant Piping Diagram when Condenser is Above or Below Evaporator

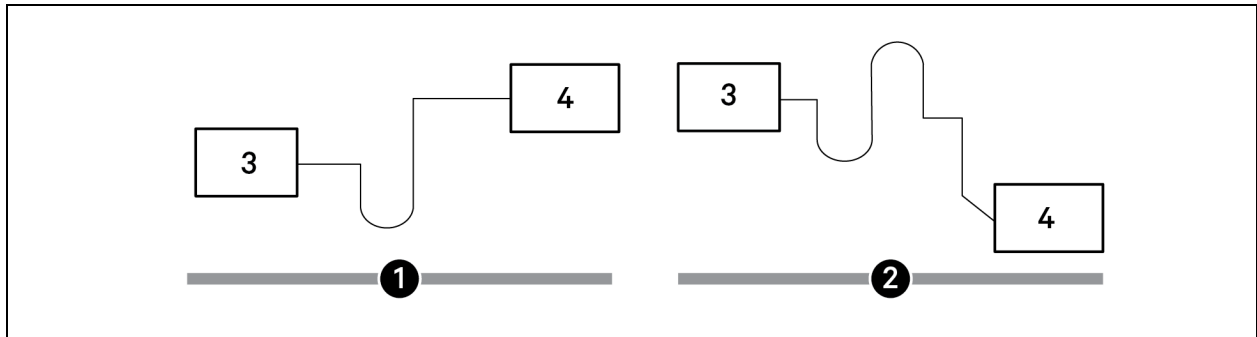

NOTE: Any horizontal pipe must be pitched down toward the condensing unit at a minimum rate of 1/2 in. (13 mm) per 10 ft (3 m) to assure oil return to compressor.

Item	Description
1	Condensing unit above evaporator
2	Condensing unit below evaporator
3	Evaporator
4	Condensing unit

6.2 Glycol Loop Piping

Contact Vertiv Application Engineering for assistance in choosing correct Vertiv™ Liebert® drycooler models. See DPN003822 included in the [Submittal Drawings](#) on page 39.

Appendices

Appendix A: Technical Support and Contacts

A.1 Technical Support/Service in the United States

Vertiv Group Corporation

24x7 dispatch of technicians for all products.

1-800-543-2378

Liebert Thermal Management Products

1-800-543-2378

Liebert Channel Products

1-800-222-5877

Liebert AC and DC Power Products

1-800-543-2378

A.2 Locations

United States

Vertiv Headquarters

505 N. Cleveland Ave.

Westerville, OH 43082, USA

Europe

Via Leonardo Da Vinci 8 Zona Industriale Tognana

35028 Piove Di Sacco (PD) Italy

Asia

7/F, Dah Sing Financial Centre

3108 Gloucester Road, Wanchai

Hong Kong

This page intentionally left blank

Appendix B: Guide Specifications

The following are the guide specifications for the Vertiv™ Liebert® DataMate.

Vertiv™ Liebert® DataMate Guide Specifications

1.0 GENERAL

1.1 Summary

These specifications describe requirements for a Thermal Management system. The system shall be designed to control temperature and humidity conditions in rooms containing electronic equipment, with good insulation and vapor barrier.

The manufacturer shall design and furnish all equipment to be fully compatible with heat dissipation requirements of the room.

1.2 Design Requirements

The Thermal Management system shall be a Liebert® DataMate factory assembled unit. The refrigeration system shall be split, with the compressor located in a remote or close-coupled condensing unit. The evaporator section shall be specifically designed for floor or wall-mounted installation and serviceable from the front of the system. Condensing units shall be designed for outdoor or indoor mounting, below the raised floor, above-dropped-ceiling, or in room installation. Refer to Section 2.3 for condensing unit guide specifications.

Standard 60 Hz units shall be CSA-certified to the harmonized U.S. and Canadian product safety standard, “CSA C22.2 No 236/UL 1995 for Heating and Cooling Equipment” and are marked with the CSA c-us logo.

The system shall be AHRI Certified™, the trusted mark of performance assurance for heating, ventilation, air conditioning and commercial refrigeration equipment, using AHRI Standard 1360.

1.3 Submittals

Submittals shall be provided with the proposal and shall include: Single-Line Diagrams; Dimensional, Electrical, and Capacity data; Piping and Electrical Connection Drawings.

1.4 Quality Assurance

The specified system shall be factory tested before shipment. Testing shall include, but shall not be limited to: Quality Control Checks, “Hi-pot” Test (two times rated voltage plus 1000 volts, per NRTL agency requirements), and Metering Calibration Tests. The system shall be designed and manufactured according to world class quality standards. The manufacturer shall be ISO 9001 certified.

1.5 Acceptable Alternatives

Acceptable alternatives shall be permitted with engineer's prior approval only. Contractor to submit a detailed summary form listing all variations to include size deviations, electrical load differences, functional and component changes and savings to end user.

2.0 PRODUCT

2.1 Standard Features/All Systems

2.1.1 Evaporator Cabinet and Frame Construction

The cabinet and chassis shall be constructed of heavy gauge, painted furniture steel. The cabinet shall be de-signed for easy installation and service access from the front only.

2.1.2 Air Distribution

The air distribution system shall be constructed with a quiet, direct-drive fan assembly equipped with multiple double-inlet blowers, self-aligning sleeve bearings, and lifetime lubrication. Fan motor(s) shall be permanent-split capacitor, high efficiency type, equipped with two speeds for air flow modulation. Dehumidification shall utilize the lower fan speed.

Air filter shall be a cleanable polypropylene monofilament type over expanded aluminum with aluminum frame with a MERV4 rating based on ASHRAE 52.2 007. It shall be easily removable from the front of the system by means of quarter-turn fasteners and shall not require system shutdown for service.

2.1.3 Microprocessor Control System

The control system shall be microprocessor-based, factory-wired into the system and tested prior to shipment. The wall-mounted control enclosure shall include a 2-line by 16-character LCD providing continuous display of operating status and alarm condition. An 8-key membrane keypad for setpoint/program control, fan speed selection and unit On/Off shall be located below the display. The control display shall be field-wired to the control board using 4-conductor field-supplied thermostat wire.

Temperature and humidity sensors shall be located in the wall box, which shall be capable of being located up to 300 ft (91.4m) from the evaporator unit.

Monitoring

The LCD shall provide On/Off indication, operating mode indication (cooling, heating, humidifying, dehumidifying), fan speed indication and current day, time, temperature and humidity (if applicable) indication. The monitoring system shall be capable of relaying unit operating parameters and alarms to the Vertiv™ Liebert® IS-UNITY-DP or the Vertiv™ Liebert® SiteScan™ monitoring systems.

Control Setpoint Parameters

- Temperature Setpoint: 65-85°F (18 to 29°C)
- Temperature Sensitivity: 1 to 9.9°F (1 to 5°C)
- Humidity Setpoint: 20-80% RH
- Humidity Sensitivity: 1 to 30% RH

The microprocessor can be set within these ranges; however, the unit may not be able to control to extreme combinations of temperature and humidity.

Unit Controls

1. Compressor Short-Cycle Control

The control system shall prevent compressor short-cycling by a 3-minute timer from compressor stop to the next start.

2. Common Alarm and Remote On/Off

A common alarm relay shall provide a contact closure to a remote alarm device. Two (2) terminals shall also be provided for remote On/Off control. Individual alarms shall be “enabled” or “disabled” from reporting to the common alarm.

3. Setback Control

The control shall be user-configurable to use a manual setpoint control or a programmable, time-based set-back control. The setback control will be based on a 5 day/2 day programmed weekly schedule with capability of accepting 2 events per program day.

4. Temperature Calibration

The control shall include the capabilities to calibrate the temperature and humidity sensors and adjust the sensor response delay time from 10 to 90 seconds. The control shall be capable of displaying temperature values in °F or °C.

5. System Auto Restart

For startup after power failure, the system shall provide automatic restart with a programmable (up to 9.9 minutes in 6-second increments) time delay. Programming can be performed either at the wall-mounted controller or from the central, site-monitoring system.

2.1.4 Alarms

1. Unit Alarms

The control system shall monitor unit operation and activate an audible and visual alarm in the event of the following factory preset alarm conditions.

- High Temperature (max 90°F, 32.2°C)
- Low Temperature (min 35°F, 1.7°C)
- High Humidity (max 85% RH)
- Low Humidity (min 15% RH)
- High Water Alarm - Lockout Unit Operation
- High Head Pressure
- Loss of Power
- Compressor Short Cycle

2. Custom Alarms (2x)

- Humidifier Problem
- Water Detected
- Custom Alarm (1)
- Custom Alarm (2)

User-customized text can be entered for the two (2) custom alarms

3. Alarm Controls

Each alarm (unit and custom) shall be individually enabled or disabled (except for high head pressure and high water in condensate pan) and can be programmed for a time delay of 0 to 255 seconds of continuous alarm condition to be recognized as an alarm. Each alarm shall also be enabled or disabled to activate the common alarm (except high head pressure and high water in condensate pan).

4. Audible Alarm

The audible alarm shall annunciate at the LCD wall box any alarm that is enabled by the operator.

5. Common Alarm

A programmable common alarm shall be provided to interface user selected alarms with a remote alarm de-vice.

6. Remote Monitoring - Vertiv™ Liebert® SiteScan™

All alarms shall be communicated to the Liebert site-monitoring system with the following information: date and time of occurrence, unit number and present temperature and humidity.

2.2 Chilled Water System Components

2.2.1 Chilled Water Control

The water circuit shall include a 2-way valve with an On/Off actuator. Design pressure shall be 300psi (2068kPa) with a maximum close-off pressure of 60psi (414kPa).

2.2.2 Chilled Water Coil

The cooling coil shall have a minimum of 2.6 ft.2 (.24m2) face area, 3 rows deep. It shall be constructed of copper tubes and aluminum fins and be mounted in a galvanized condensate drain pan. The coil shall be designed for a maximum face velocity of ____ FPM (m/s) at ___ CFM (CMH). The water circuit shall be designed to dis-tribute water into the entire coil face area. The coil shall be supplied with ___ °F (°C) entering water temperature, with a ___ °F (°C) temperature rise. The coil shall be supplied with ___ GPM (l/s) of chilled water and the pressure drop shall not exceed _____ psi (kPa).

2.3 Direct Expansion System Components

2.3.1 Direct Expansion Coil

The evaporator section shall include an evaporator coil, thermostatic expansion valve and filter-drier.

The evaporator coil shall have ___ ft.2 (m2) face area, ___ rows deep. It shall be constructed of copper tubes and aluminum fins and have a maximum face velocity of ___ FPM (m/s) at _____ CFM (CMH). An externally equalized thermostatic expansion valve shall control refrigerant flow. The coil shall be provided with a galvanized steel drain pan. The evaporator refrigerant piping shall be spun-closed and filled with a nitrogen holding charge. Field relief of the Schrader valves shall indicate a leak-free system. The evaporator unit can be coupled directly with a water/glycol condensing unit or mounted remote to the indoor or outdoor condensing unit. Evaporator and condensing unit shall be field piped using copper lines, brazed, evacuated and field charged with R-407C refrigerant.

2.4 Indoor Air-Cooled Centrifugal Fan Condensing Unit

Condensing unit components shall include condenser coil, scroll compressor, high-pressure switch, Vertiv™ Liebert® Lee-Temp refrigerant receiver, head pressure control valve, hot gas bypass system and liquid line solenoid valve. The hot gas bypass circuit shall be provided to reduce compressor cycling and improve operation under low-load conditions. Units available for [(2-ton)(3-ton)] systems.

All components shall be factory-assembled. The condensing unit refrigerant piping shall be spun-closed and filled with a nitrogen holding charge. Field relief of the Schrader valves shall indicate a leak-free system. Evap-orator and condensing unit shall be field piped using copper lines, brazed, evacuated and field charged with R-407C refrigerant. Condensing unit shall be designed for 95°F (35°C) ambient and be capable of operation to -30°F (-34°C). The condensing unit shall be mounted remote to the evaporator.

The condensing coil shall be constructed of copper tubes and aluminum fins. The condenser fan shall be centrifugal type, double inlet, direct drive and shall operate at 1050 rpm (890 rpm @ 50 Hz). The fan and motor shall be mounted on vibration isolators. The condenser fan shall be designed for ___CFM (CMH) at ____" (mm) w.g. external static pressure.

2.5 Outdoor Air-Cooled Prop Fan Condensing Unit

Condensing unit components shall include a condenser coil, a direct-drive propeller-type fan, a scroll compressor, high-pressure switch, Liebert® Lee-Temp receiver and head pressure control valve, hot gas bypass system and liquid line solenoid valve. A hot gas bypass system shall be provided to reduce compressor cycling and improve operation under low load conditions.

All components shall be factory-assembled. The condensing unit refrigerant piping shall be spun-closed and filled with a nitrogen holding charge. Field relief of the Schrader valves shall indicate a leak-free system. Evaporator and condensing unit shall be field piped using copper lines, brazed, evacuated and field charged with R-407C refrigerant. Condensing unit shall be designed for 95°F (35°C) ambient and be capable of operation to -30°F (-34.4°C).

The condenser coil shall be constructed of copper tubes and aluminum fins.

(Option) The 2- or 3-ton condensing unit shall be designed to operate at a sound level less than 58dBA.

(Option) The 2- or 3-ton condensing unit shall be designed for design ambient operation of 105°F (40.6°C).

(Option) The coil shall be epoxy-coated for extended coil life in corrosive environments, such as coastal areas. Factory-applied E-coat using immersion and baking process shall provide a flexible epoxy-coating to all coil sur-faces. Coil color shall be black and shall be protected from solar UV ray degradation with a factory-applied UV topcoat.

2.6 Indoor Close-Coupled Water/Glycol Condensing Unit

The water/glycol-cooled condensing unit shall include a scroll compressor and a water/glycol cooled condenser, and shall be capable of being close-coupled to the evaporator module. The water/glycol cooled condenser shall be designed to balance the heat rejection at _____ °F (°C) entering water/glycol temperature with a flow rate of ___ GPM (l/s) and have a total system pressure drop of _____ ft of water (kPa). An adjustable two-way water regulating valve shall be included. The condenser water/glycol circuit shall be designed for a static operating pressure of 150psi (1034kPa).

All components shall be factory-assembled. The condensing unit refrigerant piping shall be spun-closed and filled with a nitrogen holding charge. Field relief of the Schrader valves shall indicate a leak-free system. Evap-orator and condensing unit shall be field piped using copper lines, brazed, evacuated and field charged with R-407C refrigerant. An integral wiring harness for single point power connection shall be provided for field wiring of evaporator and condensing unit together.

2.7 Indoor Remote Water/Glycol-Cooled Condensing Unit

The water/glycol condensing unit shall include a scroll compressor, high-pressure switch, coaxial condenser, water-regulating valve, hot gas bypass system and liquid line solenoid valve. A hot gas bypass circuit shall be provided to reduce compressor cycling and improve operation under low-load conditions. The condensing unit refrigerant piping shall be spun-closed and filled with a nitrogen holding charge. Field relief of the Schrader valves shall indicate a leak-free system. Evaporator and condensing unit shall be field piped using copper lines, brazed, evacuated and field charged with R-407C refrigerant. Units available for [(2-ton)(3-ton)] systems.

The water/glycol condensing unit shall be equipped with a coaxial condenser having a total system pressure drop of _____ ft. of water (kPa) and a flow rate of _____ GPM (l/s) with _____ °F (°C) entering water/glycol temperature.

The condenser circuit shall be pre-piped with a [(2-way) (3-way)] regulating valve which is head-pressure actuated.

The condenser water/glycol circuit shall be designed for a static operating pressure of [(150psi (1034kPa)) (350 PSI (2413 kPa))].

2.8 Factory-Installed Options

2.8.1 Electric Reheat

The electric reheat shall be low-watt density, tubular element and shall include agency approved safety switch to protect the system from overheating. The capacity of the reheat coil shall be

_____ BTU/HR, ____ kW, controlled in 1 stage.

2.8.2 Steam Generating Humidifier

The environmental control system shall be equipped with a steam generating humidifier that is controlled by the microprocessor control system. It shall be complete with disposable canister, all supply and drain valves, 1" (25.4mm) air gap on fill line, inlet strainer, steam distributor, and electronic controls. The need to change canister shall be annunciated on the microprocessor wall-box control panel. The humidifier shall have a capacity of 3 lb./hr. (1.4kg/h). An LED light on the humidifier assembly shall indicate cylinder full, overcurrent detection, fill system fault, and end of cylinder life conditions.

2.9 Ship-Loose Accessories

2.9.1 Remote Sensors

The unit shall be supplied with remote temperature and humidity sensors. The sensors shall be connected to the unit by a 30 ft. (9m) shielded cable.

2.9.2 Condensate Pump

The condensate pump shall have the capacity of _____ GPH (____ l/h) at ____ ft. head (____ kPa). It shall be complete with integral float switch, discharge check valve, pump, motor assembly and reservoir. A secondary float switch shall be provided to permit field wiring to the unit control to shut down the evaporator upon a high water level condition.

2.9.3 Step-Down Transformer

A step-down transformer shall be provided for [(Indoor Evaporator) (Close-Coupled Water/Glycol Condensing Unit) (Outdoor Air-Cooled Condensing Unit)] needing 277V input power voltage. The transformer shall be coated with epoxy and contained in an enclosed, non-ventilated electrical box with adaptable mounting brackets, suitable for [(indoor) (outdoor)] mounting.

2.9.4 Liebert Local Monitoring Systems, Auto-changeover and Leak Detection

Provide indicated quantities of the following:

_____ Leak Detection System(s) Model _____

_____ Remote Monitor(s) Model _____

_____ Auto-changeover Control(s) Model _____

2.9.5 Remote Monitoring and Control—IS-UNITY-DP and BMS

The Vertiv™ Liebert® IS-UNITY-DP BMS Monitoring Solution shall provide SNMP v1/v2c/v3, BACnet IP, BACnet MSTP, Modbus TCP/IP, and Modbus RTU monitoring capability to the Vertiv™ Liebert® DataMate system. Card shall employ Ethernet and RS-485 networks to monitor and manage a wide range of operating parameters pertaining to the cooling system. The Unity card shall provide access to the Liebert® DataMate remotely via a web interface and shall support Vertiv™ Liebert® Nform connectivity. The wall-mount kit for field-installation shall include the IS-UNITY-DP card, power/communication interface card, painted enclosure, 120V wall outlet transformer with 6ft (2m) low voltage power wire, and full instructions. Field-supplied wiring for communication to the Liebert® DataMate and to other systems shall be required to access features.

2.9.6 Vertiv™ Liebert® SiteScan™ Site Monitoring System

A Liebert® SiteScan™ Site Monitoring System Model _____ shall be provided for remote monitoring of the Liebert® DataMate unit and monitoring of other Liebert support equipment. The Liebert® SiteScan™ shall have the capability to monitor and change (at the user direction) the temperature and humidity setpoints and sensitivities of each unit. The printer shall provide the user with chronological alarm information. It shall also be capable of being programmed to print out environmental conditions or operating modes at each unit.

2.9.7 Drycooler

The Liebert drycooler shall be a low-profile, direct-drive propeller fan-type air-cooled unit. The drycooler shall be constructed with an aluminum cabinet and a copper-tube aluminum fin coil, and one or more direct drive fans. All electrical connections and controls shall be enclosed in an integral, NEMA 3R rated electrical panel section of the drycooler. The drycooler shall be quiet and corrosion resistant.

The drycooler shall be designed for ____ °F (°C) ambient.

2.9.8 Glycol Pump Package

The system shall include a centrifugal pump mounted in a weatherproof and vented enclosure. The pump shall be rated for ____ gpm (l/s) at ____ ft. (kPa) of head, and operate on ____ volt, ____ phase, _____ Hz.

3.0 EXECUTION

3.1 Installation of Air Conditioning Units

3.1.1 General

Install air conditioning units in accordance with manufacturer's installation instructions. Install unit plumb and level, firmly anchored in locations indicated and maintain manufacturer's recommended clearances.

3.1.2 Electrical Wiring

Install and connect electrical devices furnished by manufacturer but not specified to be factory mounted. Furnish copy of manufacturer's electrical connection diagram submittal to electrical contractor.

3.1.3 Piping Connections

Install and connect devices furnished by manufacturer but not specified to be factory mounted. Furnish copy of manufacturer's piping connection diagram submittal to piping contractor.

3.1.4 Supply and Drain Water Piping

Connect water supply and drains to air conditioning unit. Provide pitch and trap as manufacturer's instructions and local codes require.

3.1.5 Field Quality Control

Startup air conditioning units in accordance with manufacturer's start up instructions. Test controls and demonstrate compliance with requirements.

This page intentionally left blank

Appendix C: Submittal Drawings

The submittal drawings are in the order of document part number (DPN). [Submittal Drawings Contents](#) below, groups the drawings by topic/application.

Table C.1 Submittal Drawings Contents

Document Number	Title
Planning Dimensions - Evaporators/Chilled-water Units	
DPN000262	Cabinet Dimensions, Evaporator/Chilled-water Unit
DPN000269	Cabinet Dimensions, Water/Glycol Condensing Unit - Close-coupled
Planning Dimensions - Indoor Condensing Units	
DPN004420	Cabinet Dimensions, Air-cooled units
DPN004421	Cabinet Dimensions, Water/Glycol-cooled units
Planning Dimensions - Outdoor Condensing Units	
DPN004418	Cabinet Dimensions, Prop-fan Condensing Unit with horizontal air discharge
DPN003094	Optional Anchorage Plan, Prop-fan Condensing Unit with horizontal air discharge
Piping General Arrangement	
DPN004406	Piping, Air-cooled models
DPN004405	Piping, Split-system Water/Glycol models
DPN004403	Piping, Close-coupled Water/Glycol and Chilled-water models
DPN003822	Multiple Drycoolers and Cooling Units on Common Glycol Loop
Piping Connections - Evaporator and Chilled-water Units	
DPN004306	Piping Connections
Condensate Pump Connections	
DPN004306	Field-installed pump connection
Piping Connections - Split-system Indoor Condensing Units	
DPN004420	Piping Connections, Air-cooled condensing unit
DPN004421	Piping Connections, Water/Glycol-cooled condensing unit
DPN004309	Piping Connections, Close-coupled Water/Glycol-cooled units
DPN004308	Piping Connections, Prop-fan Condensing Unit, Horizontal Discharge

Table C.1 Submittal Drawings Contents (continued)

Document Number	Title
Electrical Connections - Evaporator and Chilled-water Units	
DPN000264	Electrical Connections, Air-cooled and Chilled-water units
DPN000271	Electrical Connections, Water/Glycol-cooled units
DPN004912	Arrangement and Dimensions, IS-UNITY-DP for BMS Communication
DPN004854	Electrical Connections, IS-UNITY-DP for BMS Communication
Electrical Connections - Split-system Indoor Condensing Units	
DPN000207	Electrical Connections, Air-cooled
DPN000209	Electrical Connections, Water/Glycol-cooled units

CABINET DIMENSIONAL DATA FAN/COIL & CHILLED WATER MODULE

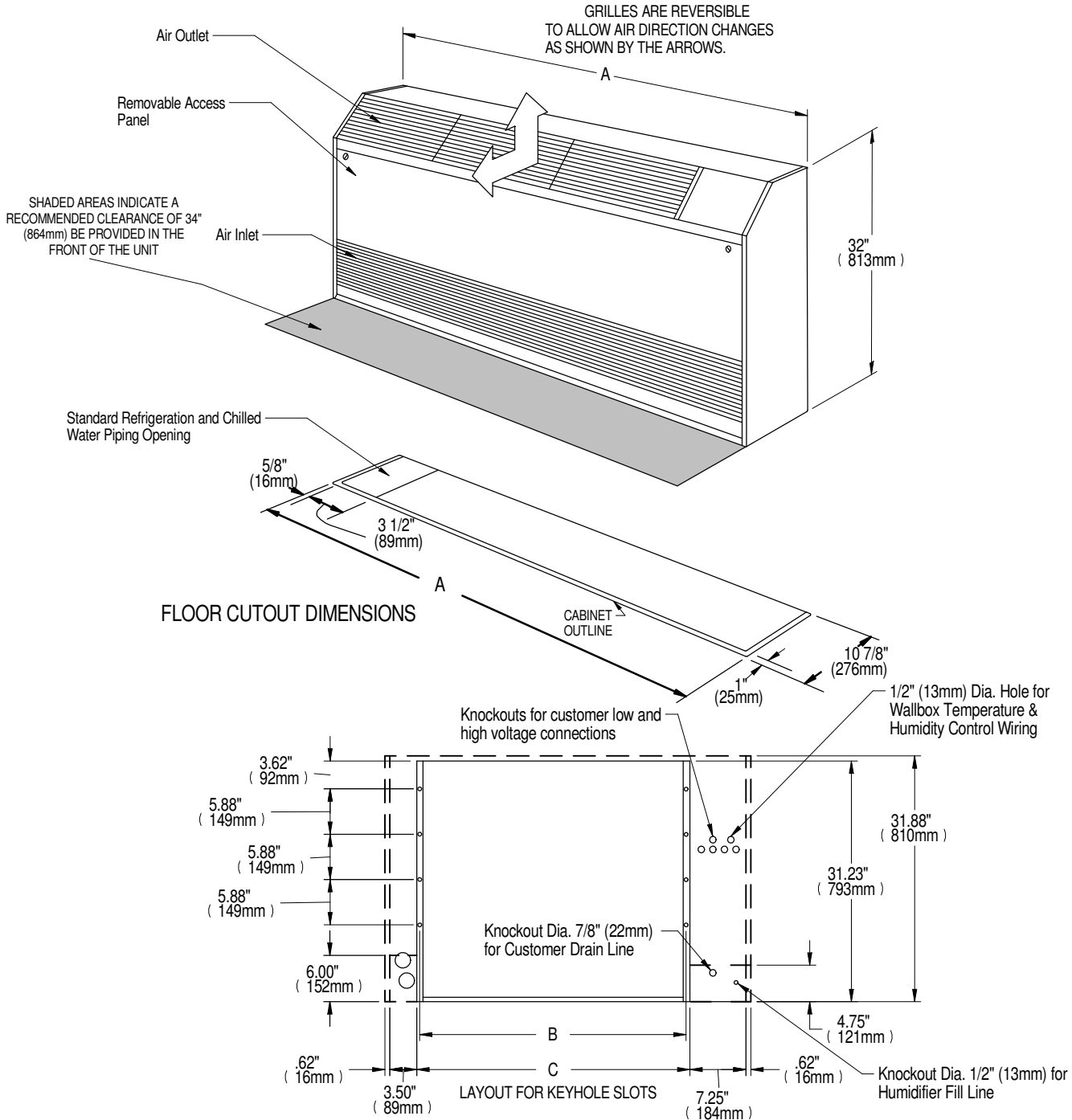

MODEL	DIMENSIONAL DATA in. (mm).			UNIT OPERATING WEIGHT. lbs. (kg)
	A	B	C	
DME020E	46 1/2 (1181)	33 3/4 (857)	34 7/16 (874)	230 (104)
DME027E				330 (150)
DME037E	64 1/8 (1628)	51 1/2 (1308)	52 3/16 (1325)	365 (165)
DME044C				

CABINET DIMENSIONAL DATA WATER/GLYCOL COOLED CONDENSING MODEL

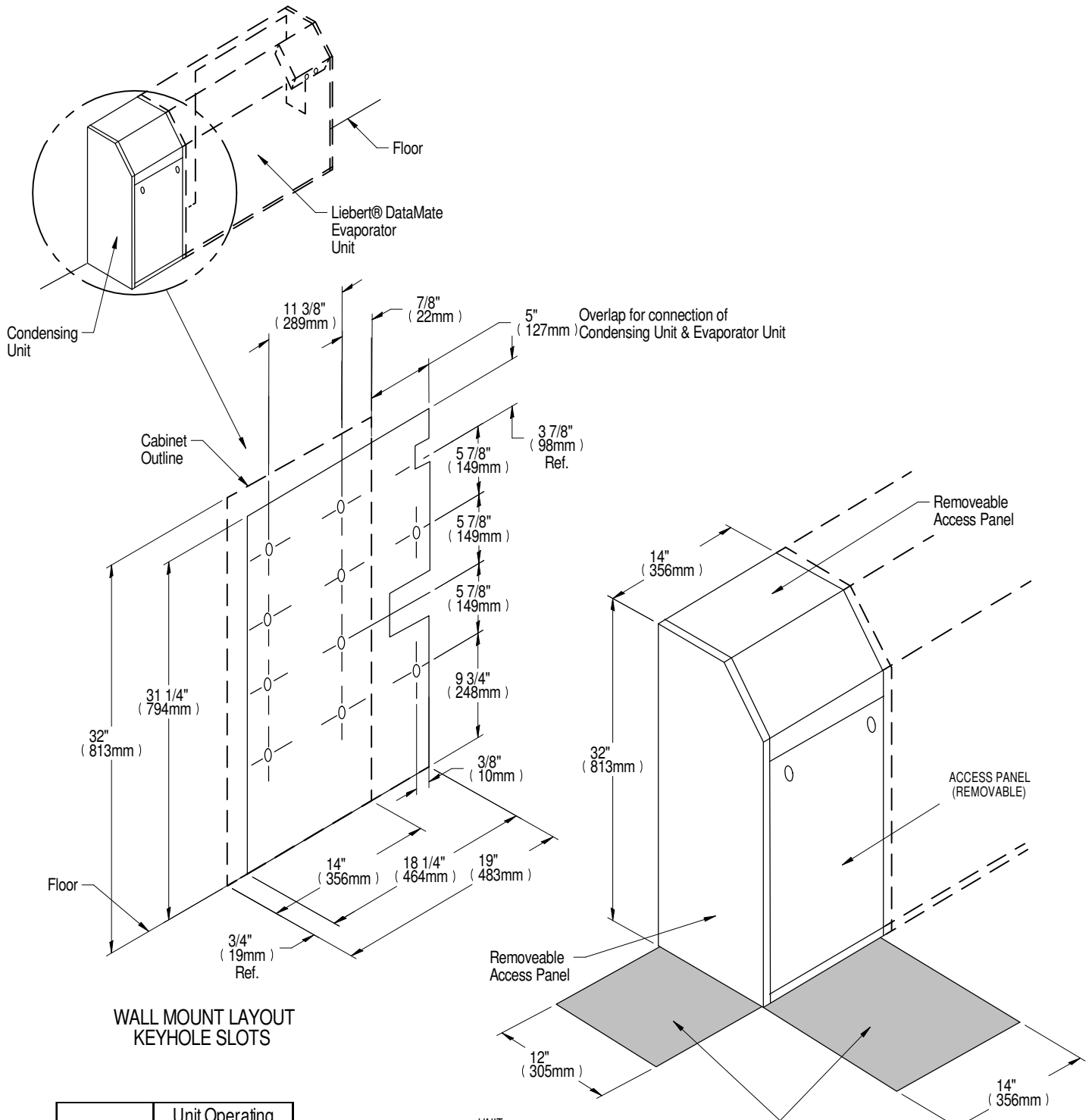

WALL MOUNT LAYOUT
KEYHOLE SLOTS

Model	Unit Operating Weight lbs. (kg)
DMC022WG	169 (77)
DMC029WG	172 (78)
DMC040WG	172 (78)

LIEBERT® MINI-MATE2

CABINET DIMENSIONAL DATA & PRIMARY CONNECTION LOCATIONS 2 TON INDOOR CONDENSING MODELS

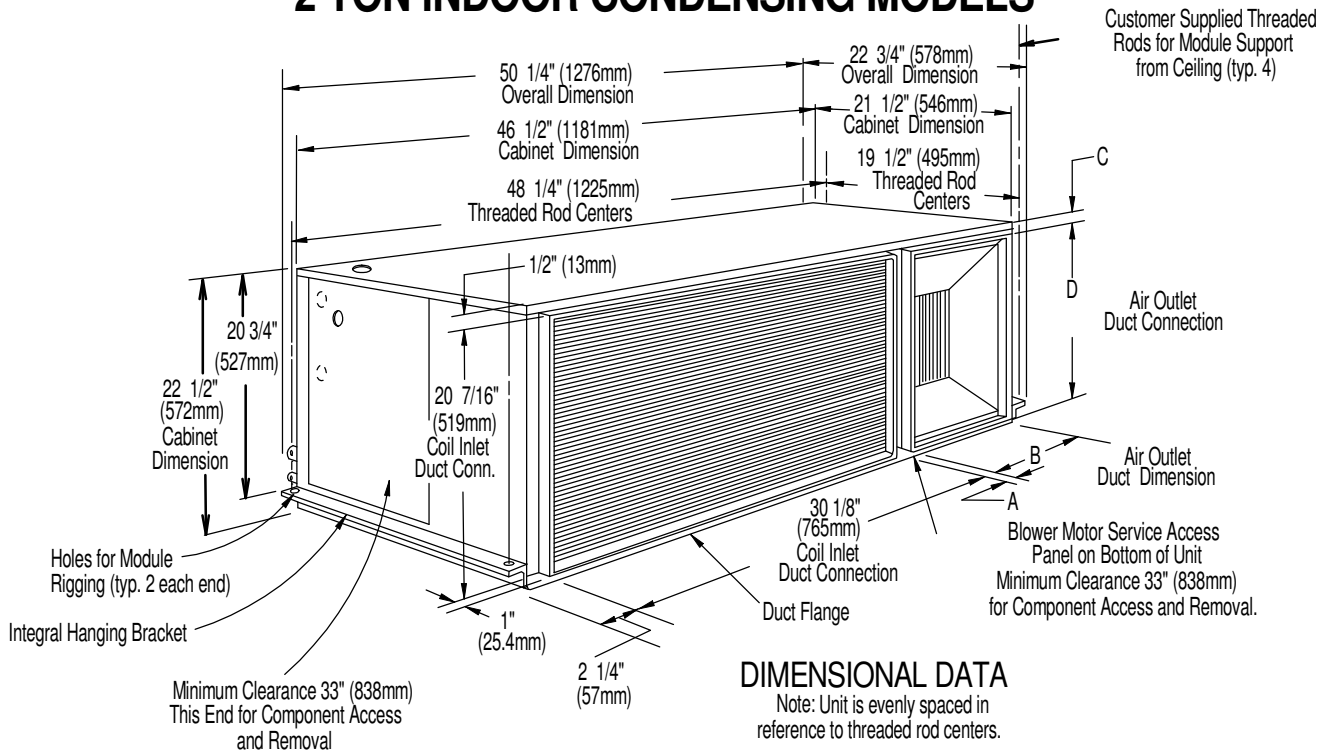

Model #	Dimensions in. (mm)				Unit Net Wt. lbs. (kg)	Refrigeration Connection Sizes O.D. Cu	
	A	B	C	D		Suction	Liquid
MC*24A	1-7/16 (37)	11-7/16 (290)	1/2 (13)	20-7/16 (519)	230 (104)	5/8"	3/8"

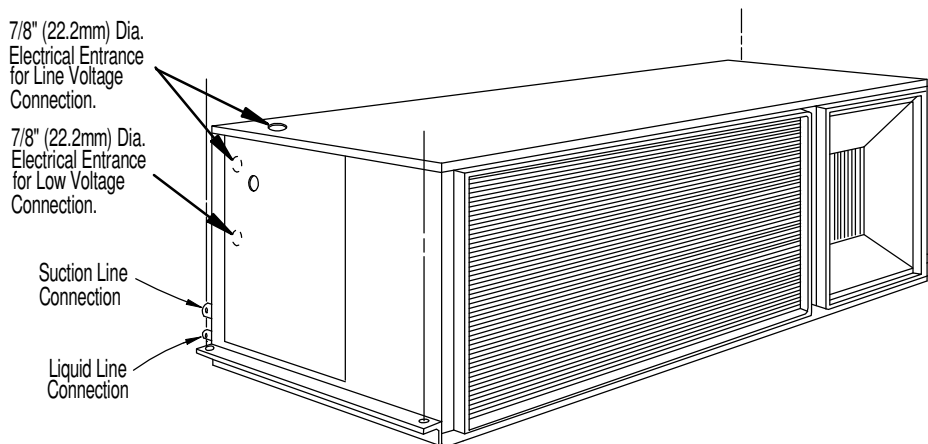

PIPING CONNECTIONS

CABINET DIMENSIONAL DATA & PRIMARY CONNECTION LOCATIONS

2 TON WATER/GLYCOL COOLED INDOOR CONDENSING MODULE

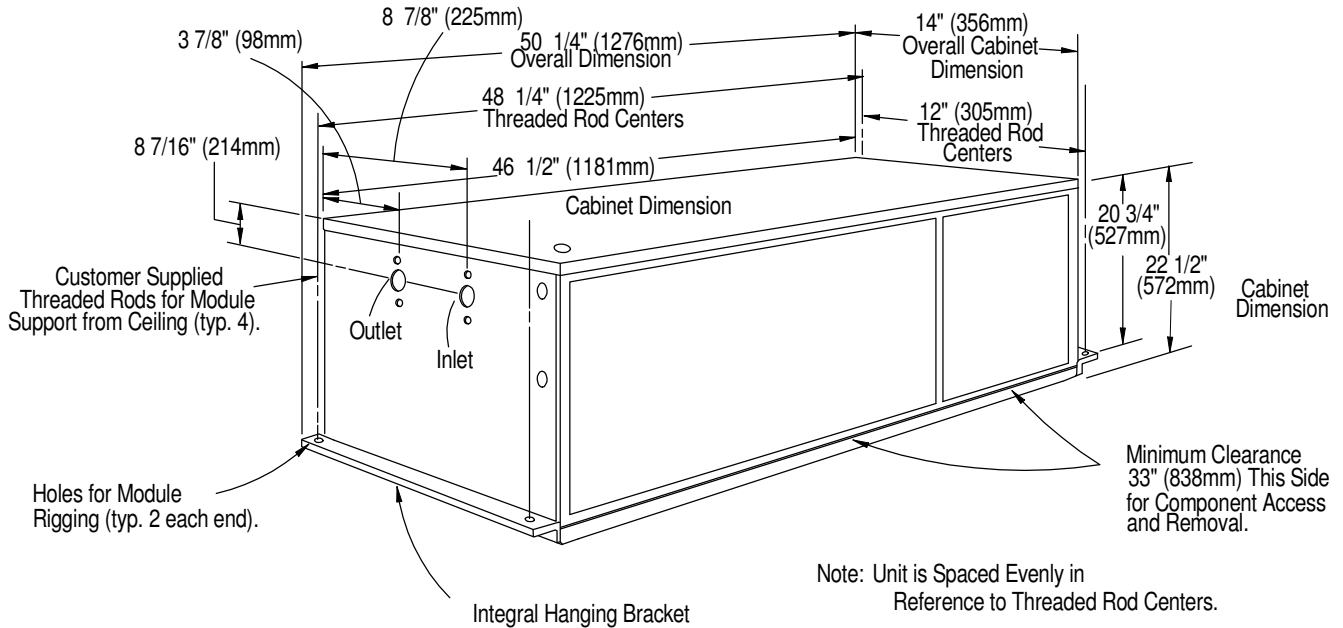

DIMENSIONAL DATA

Model #	Unit Net Weight lbs. (kg)	Refrigerant Connection Sizes O.D. Cu	
		Suction	Liquid
60 Hz			
MC*26W	175 (79)	5/8"	3/8"

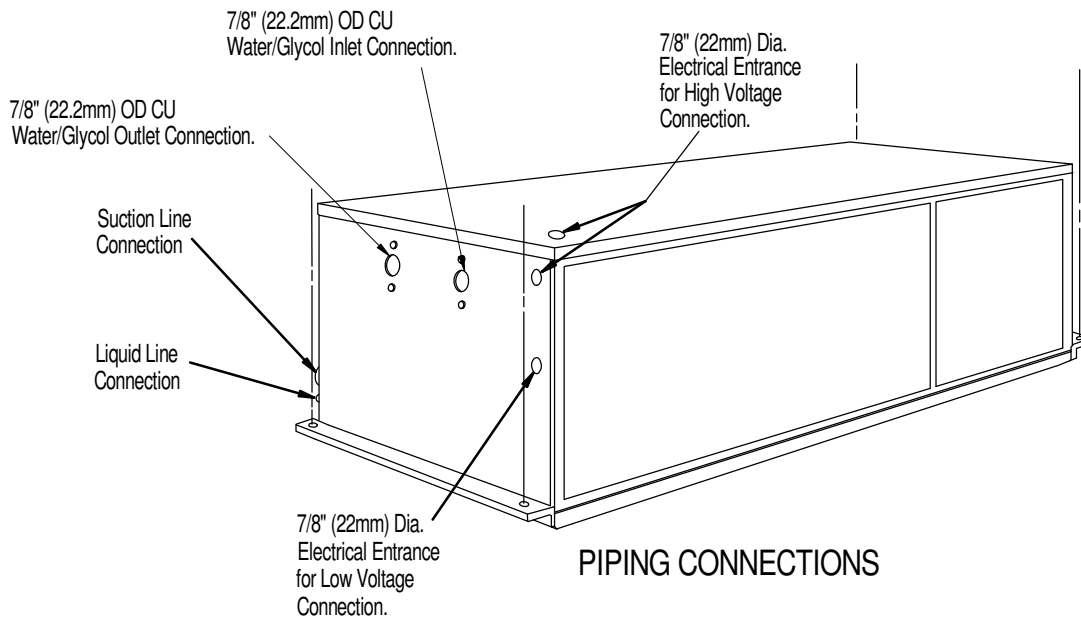

CABINET DIMENSIONAL DATA CONDENSING UNIT W/ HORIZONTAL AIR DISCHARGE

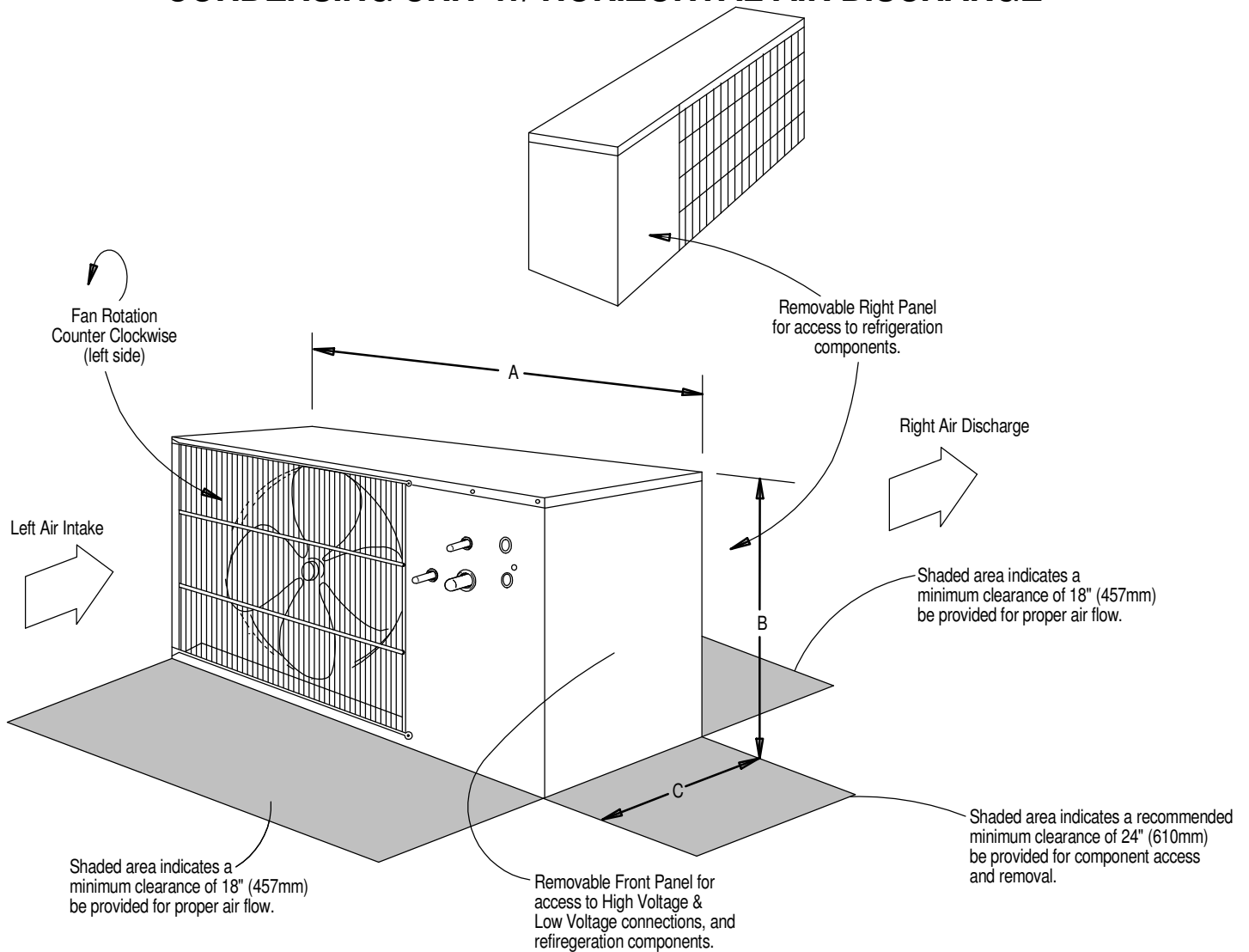

MODEL NUMBERS		DIMENSIONAL DATA IN. (mm)			MODULE WEIGHT
60 HZ	50HZ	A	B	C	lbs. (kg) net
PFH014A-L	NA	40 (1016)	23 1/2 (597)	18 (457)	200 (91)
PFH020A-L	NA				
PFH027A-L	NA				
PFH027A-H	NA	48 (1219)	31 (787)	18 (457)	241 (109)
PFHZ27A-L	NA				
PFH037A-L	PFH036A-L				
PFH042A-L	PFH041A-L	53 (1343)	36 1/4 (918)	18 (457)	351 (159)
PFH037A-H	PFH036A-H				
PFHZ37A-L	PFHZ36A-L				
PFH042A-H	PFH041A-H				
PFHZ42A-L	PFHZ41A-L				
PFH067A-L	PFH066A-L				

OPTIONAL ANCHORAGE PLAN

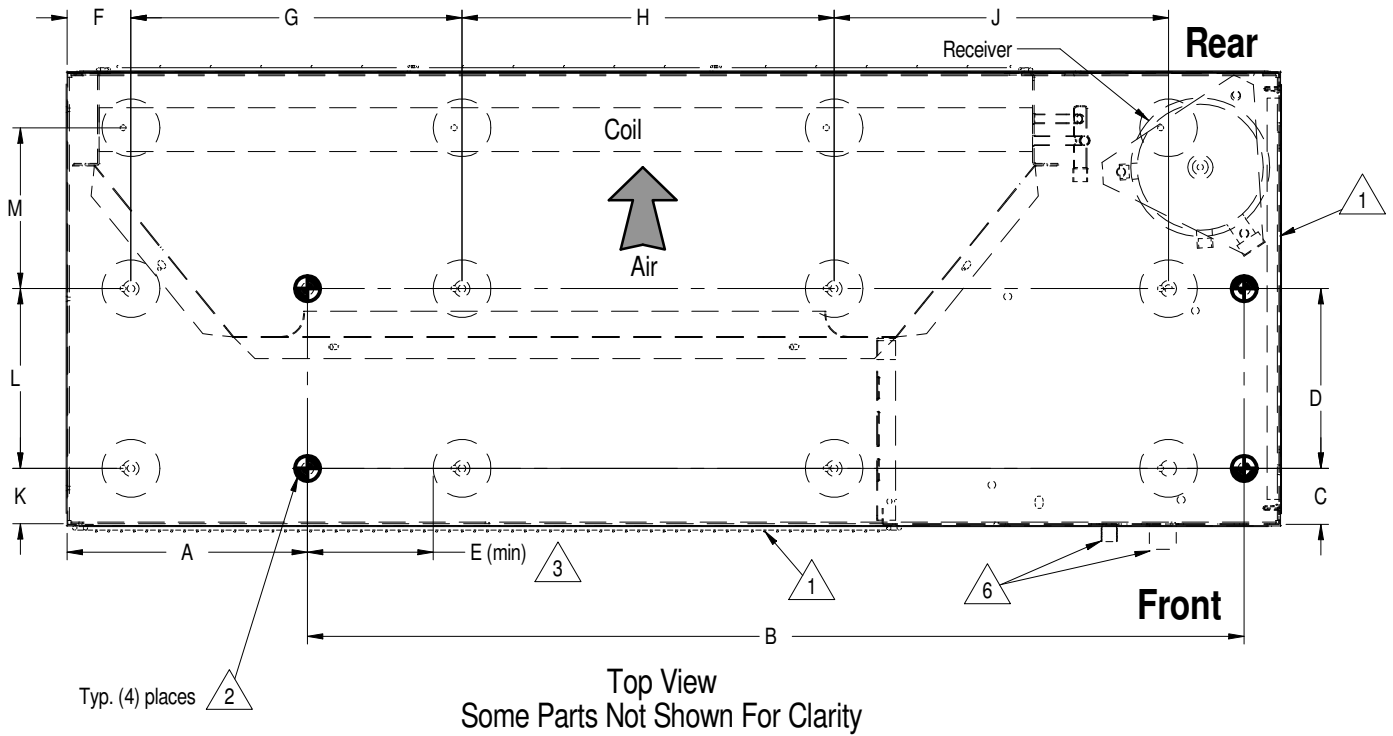

MODEL NUMBERS		DIMENSIONAL DATA IN. (mm)											
60 HZ	50HZ	A	B	C	D	E (min)	F	G	H	J	K	L	M
PFH014A-L	NA	8-5/8 (219)	30-1/4 (769)	2-1/2 (64)	8-1/2 (216)	1 (25)	6-1/2 (165)	13-13/16 (351)	15 (381)	NA	2-1/2 (64)	15-1/16 (382)	NA
PFH020A-L													
PFH027A-L													
PFH027A-H													
PFHZ27A-L	PFH036A-L	9-9/16 (242)	37-1/8 (943)	2-1/4 (57)	7-1/8 (181)	1-7/8 (47)	2-9/16 (64)	13-1/8 (333)	14-3/4 (375)	13-1/4 (337)	2-1/4 (57)	7-1/8 (181)	6-3/8 (162)
PFH037A-L													
PFH042A-L	PFH041A-L	9-5/16 (236)	43 (1092)	2-5/16 (58)	7-1/8 (181)	2-9/16 (65)	2-1/2 (63)	15-1/16 (383)	15-11/16 (398)	15-3/8 (391)	2-5/16 (58)	7-1/8 (181)	6-3/8 (162)
PFH037A-H	PFH036A-H												
PFHZ37A-L	PFHZ36A-L												
PFH042A-H	PFH041A-H												
PFHZ42A-L	PFHZ41A-L	9-5/16 (236)	43 (1092)	2-5/16 (58)	7-1/8 (181)	2-9/16 (65)	2-1/2 (63)	15-1/16 (383)	15-11/16 (398)	15-3/8 (391)	2-5/16 (58)	7-1/8 (181)	6-3/8 (162)
PFH067A-L	PFH066A-L												

Notes:

1. Front Grille and Right End Panel will need to be removed to access anchor holes, Top panel may be removed for additional access. All removed parts must be reinstalled.
2. 1/2"(13mm) Diameter hole, use for unit anchor.
3. All dimensions have a tolerance of $\pm 1/16"$.
4. F, G, H, J, K, L and M dimensions are for the foot locations.
5. The use of this anchor plan is optional and installer will assume responsibility for suitable anchorage.
6. Supply and return piping connections

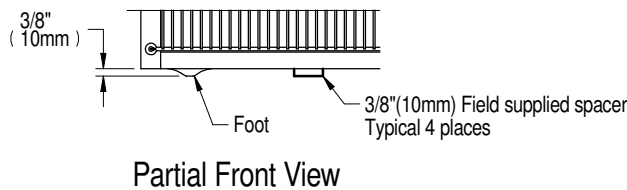

GENERAL ARRANGEMENT DIAGRAM SPLIT SYSTEMS AIR COOLED

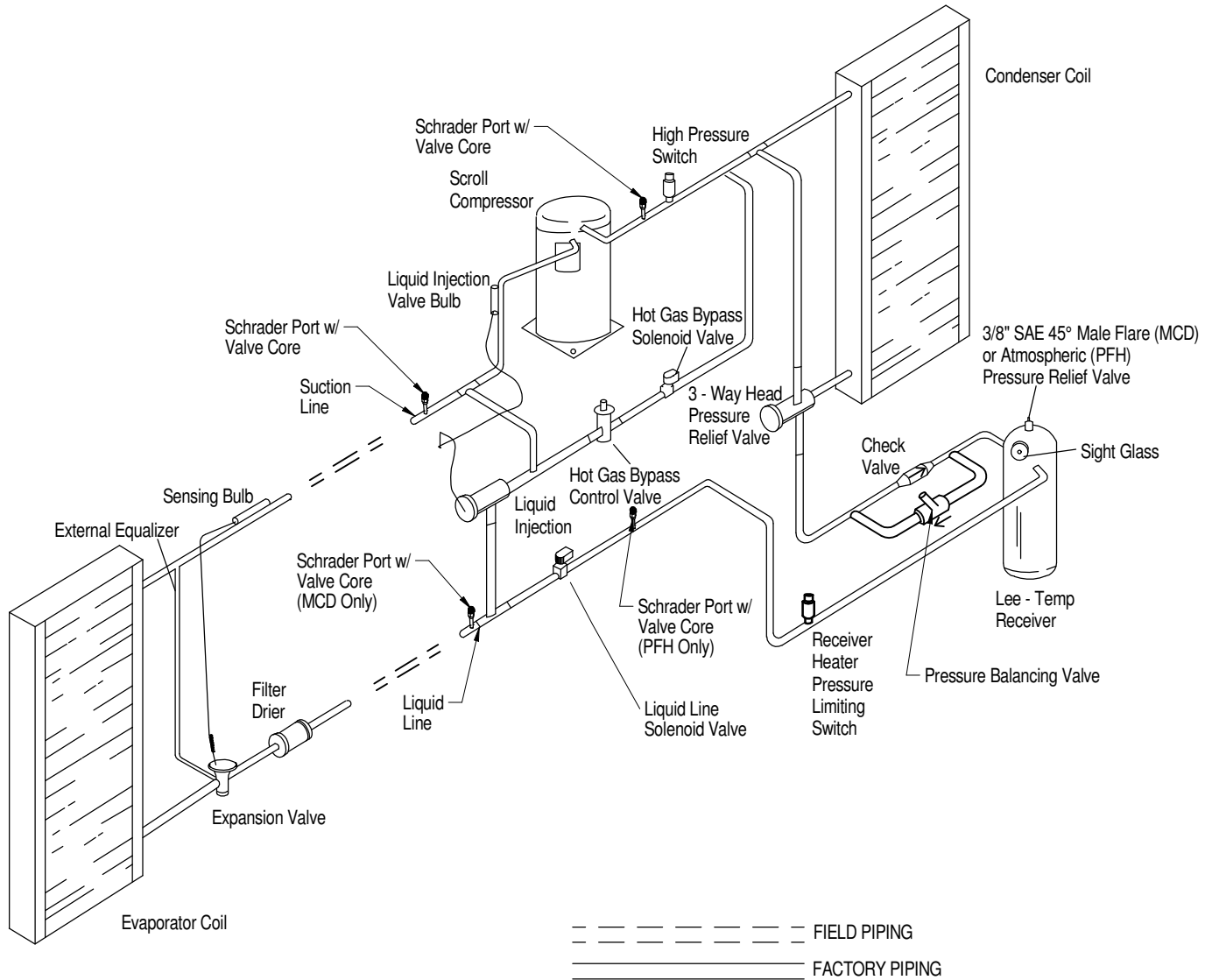

GENERAL ARRANGEMENT DIAGRAM SPLIT SYSTEMS WATER/GLYCOL COOLED

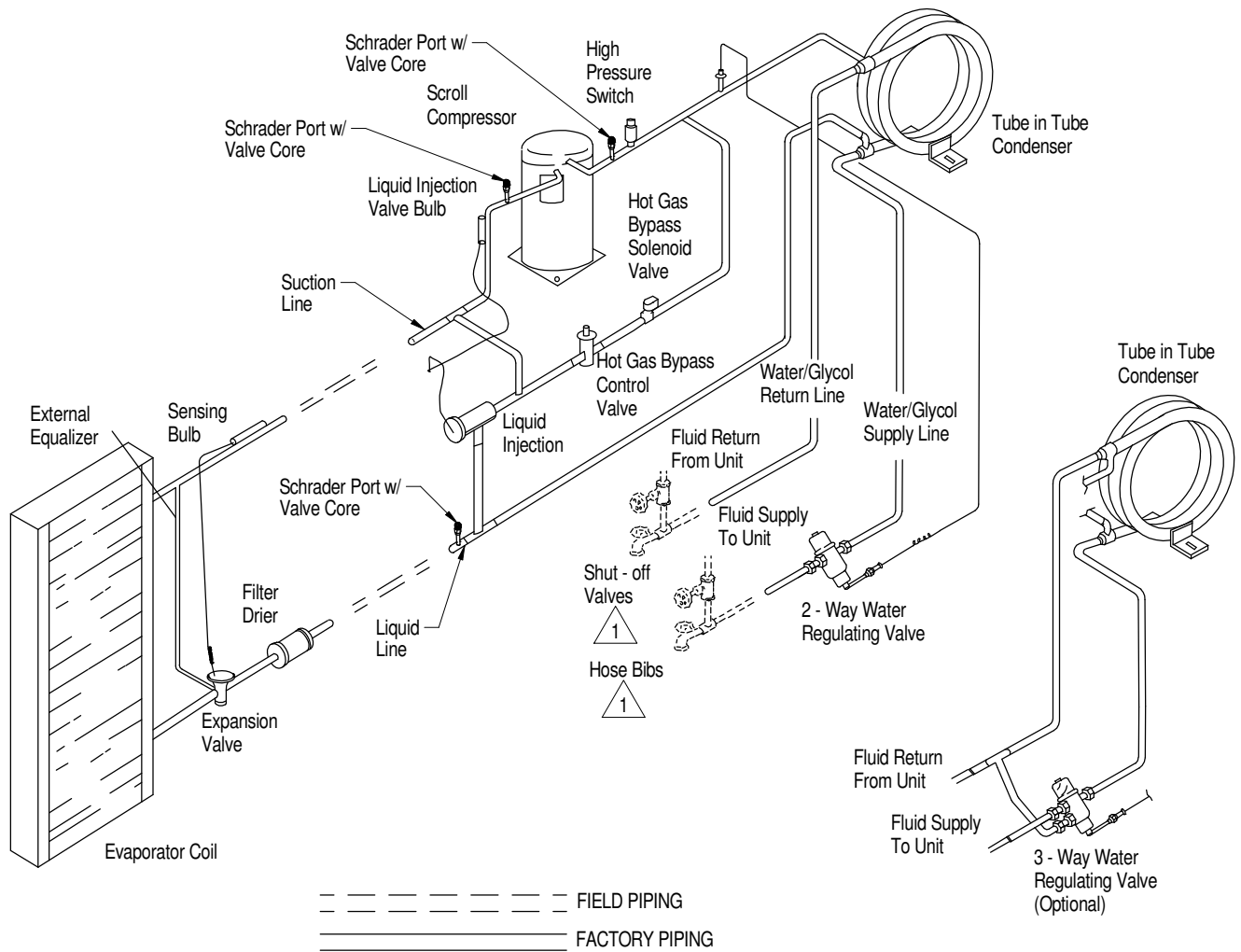

Notes:

1. Components are not supplied by Vertiv, but are required for proper circuit operation and maintenance.

GENERAL ARRANGEMENT DIAGRAM CLOSE-COUPLED WATER/GLYCOL & CHILLED WATER MODELS

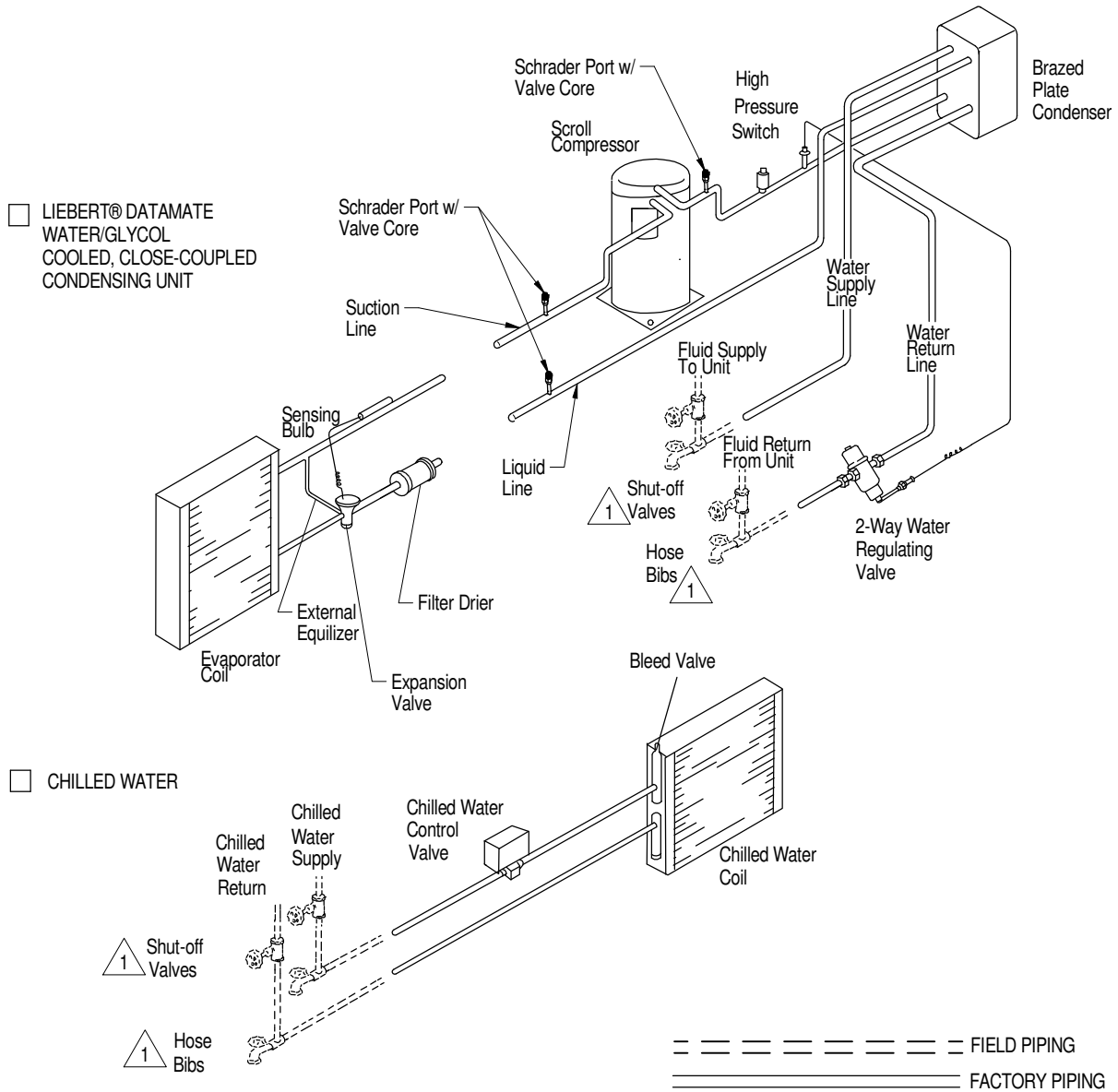

Notes:

1. Components are not supplied by Vertiv, but are required for proper circuit operation and maintenance.



LIEBERT® DRYCOOLER

PIPING SCHEMATIC

MULTIPLE DRYCOOLERS & COOLING UNITS ON COMMON GLYCOL LOOP

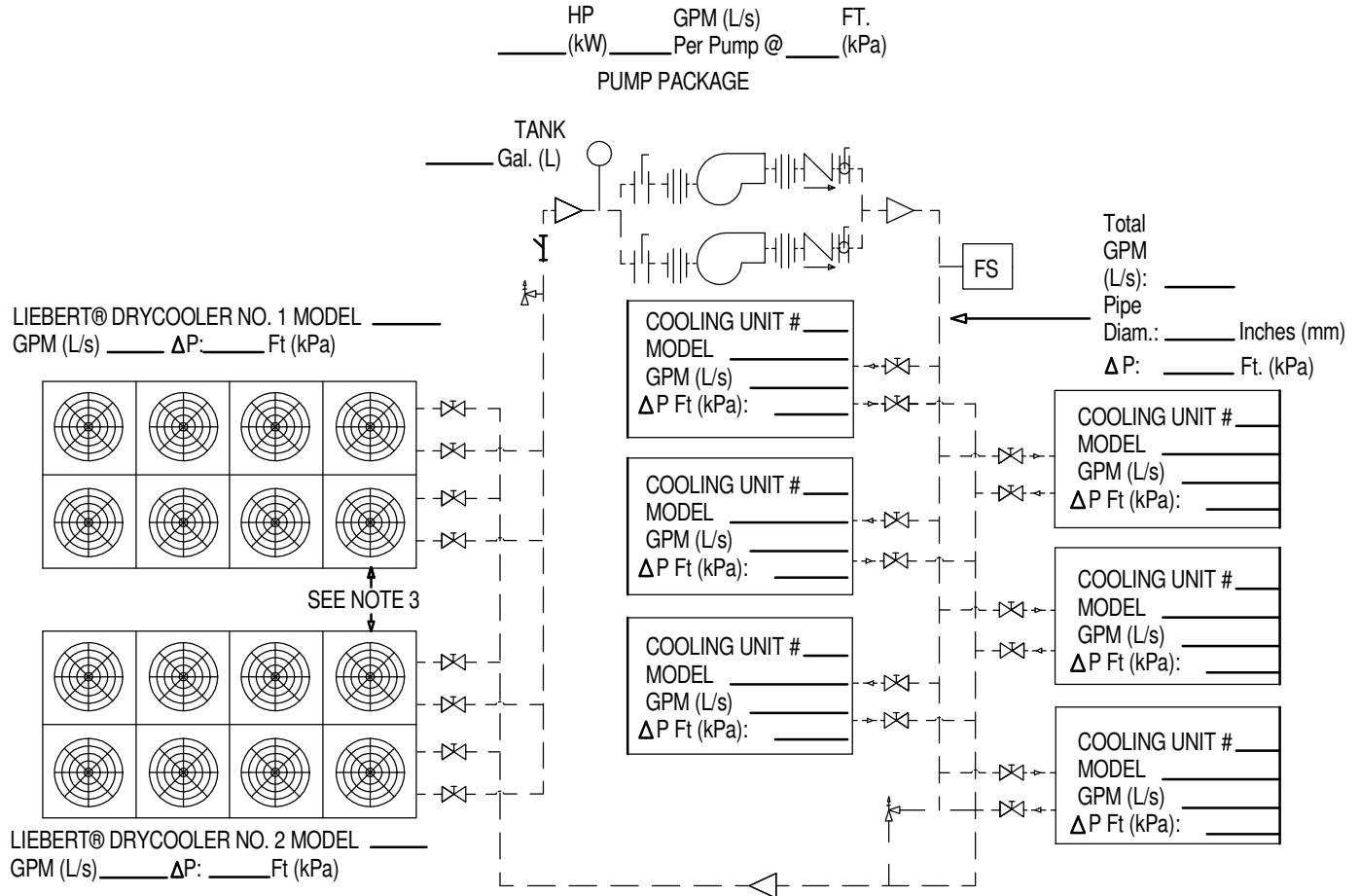

LEGEND

- GATE VALVE
- CHECK VALVE
- BUTTERFLY VALVE
- RELIEF VALVE
- UNION
- BALL OR FLOW CONTROL VALVE
- FLOW SWITCH
- ΔP : PRESSURE DROP
- STRAINER/FILTER

NOTES:

1. PRESSURE AND TEMPERATURE GAUGES (OR PORTS FOR SAME) ARE RECOMMENDED TO MONITOR COMPONENT PRESSURE DROPS AND PERFORMANCE.
2. FLOW MEASURING DEVICES, DRAIN AND BALANCING VALVES TO BE SUPPLIED BY OTHERS AND LOCATED AS REQUIRED.
3. SEE PRODUCT LITERATURE FOR INSTALLATION GUIDELINES AND CLEARANCE DIMENSIONS.
4. DRAWING SHOWS DUAL PUMP PACKAGE. ALTERNATE PUMP PACKAGES WITH MORE PUMPS MAY BE CONSIDERED, CONSULT SUPPLIER.
5. DEPENDING ON THE LIEBERT® DRYCOOLER COIL CIRCUITING IT MAY HAVE 2 IN/OUT OR 4 IN/OUT CONNECTION POINTS.
6. INSTALL EXPANSION OR COMPRESSION TANK AT THE HIGHEST POINT OF THE SYSTEM.

PRIMARY CONNECTION LOCATIONS FAN/COIL & CHILLED WATER MODULES

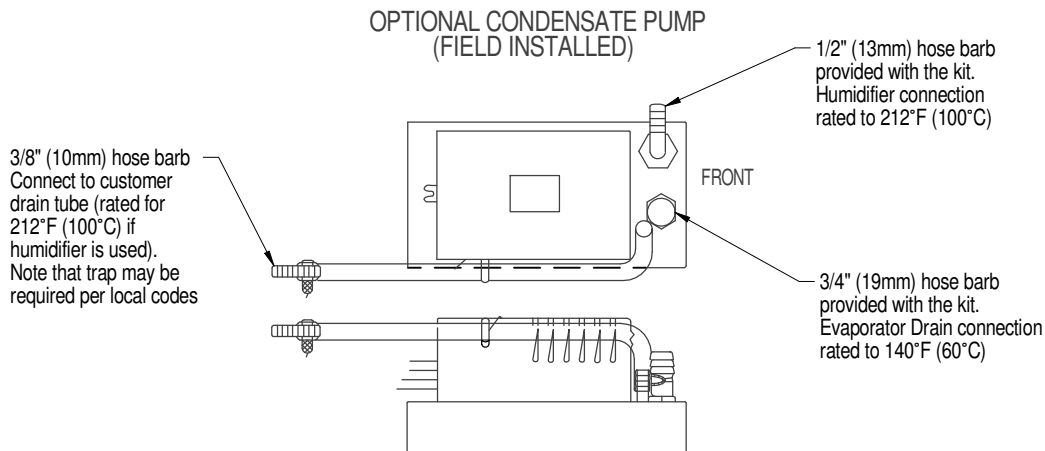
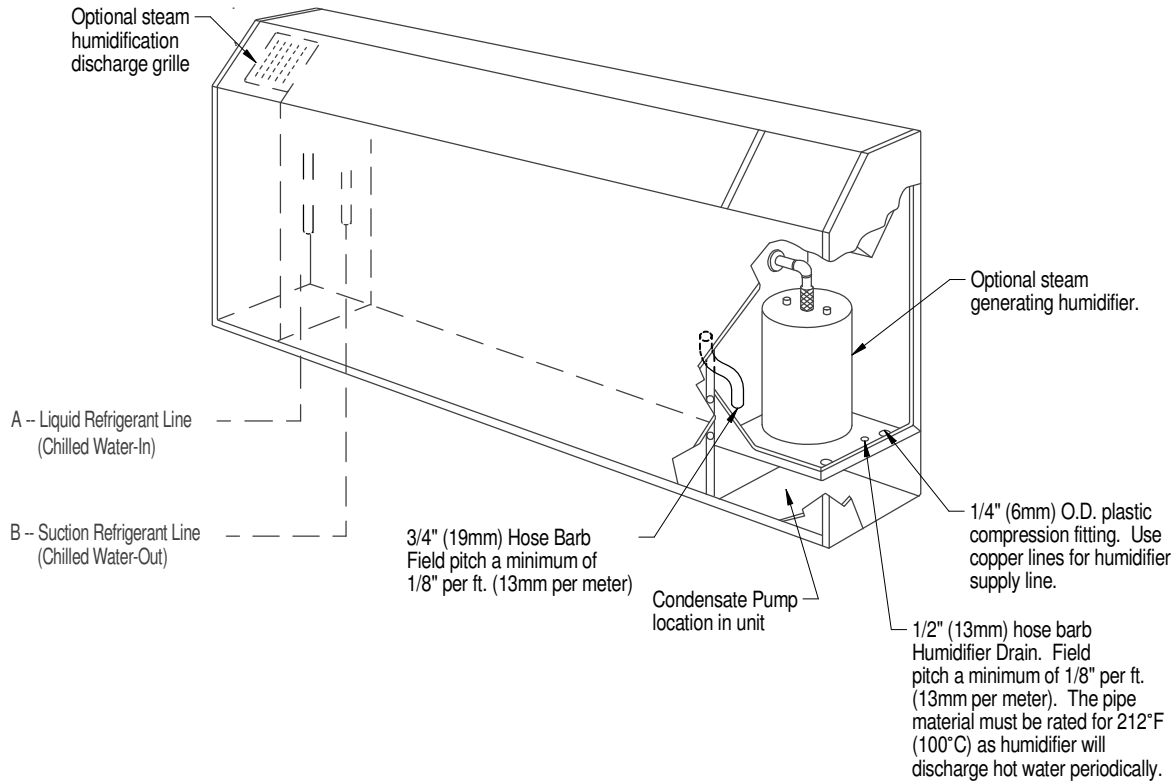

UNIT PIPING OUTLET CONNECTION SIZES O.D. CU		
MODEL NUMBER	LIQUID LINE A	SUCTION LINE B
DME020E	3/8"	5/8"
DME027E		7/8"
DME037E		
	WATER INLET	WATER OUTLET
DME044C	7/8"	7/8"

LIEBERT® MINI-MATE2

CABINET DIMENSIONAL DATA & PRIMARY CONNECTION LOCATIONS 2 TON INDOOR CONDENSING MODELS

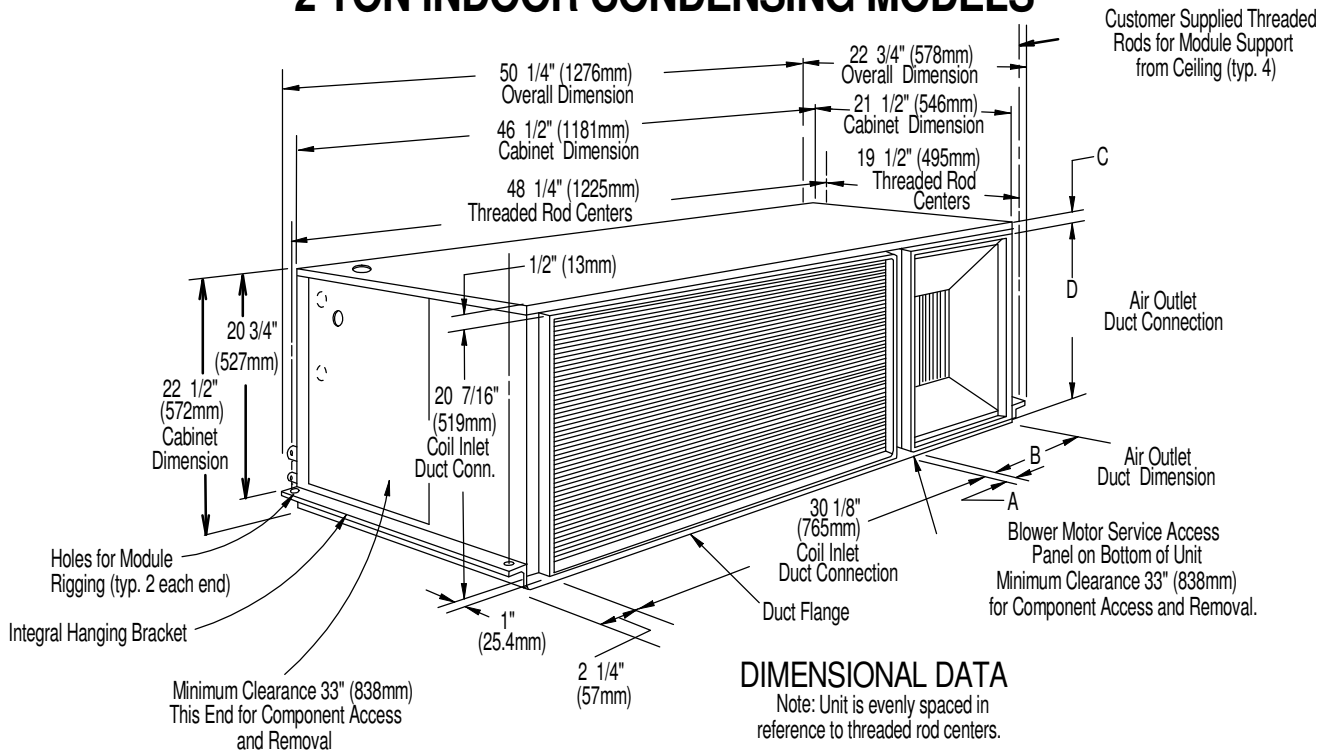

Model #	Dimensions in. (mm)				Unit Net Wt. lbs. (kg)	Refrigeration Connection Sizes O.D. Cu	
	A	B	C	D		Suction	Liquid
MC*24A	1-7/16 (37)	11-7/16 (290)	1/2 (13)	20-7/16 (519)	230 (104)	5/8"	3/8"

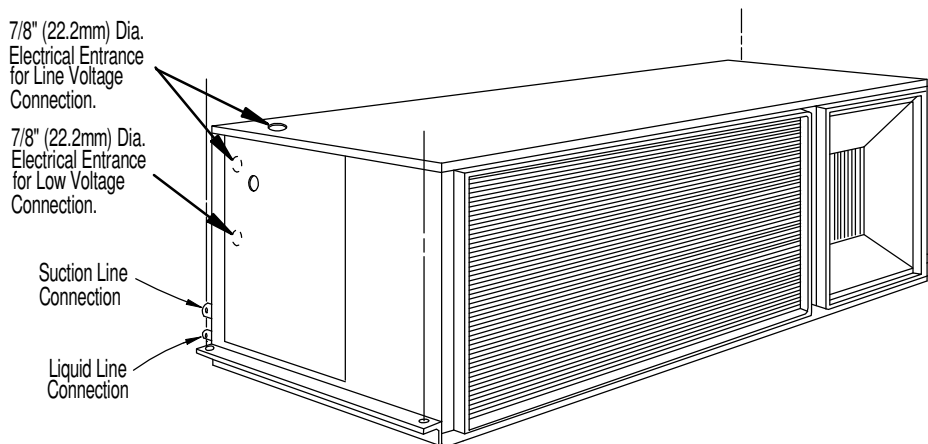

PIPING CONNECTIONS

CABINET DIMENSIONAL DATA & PRIMARY CONNECTION LOCATIONS

2 TON WATER/GLYCOL COOLED INDOOR CONDENSING MODULE

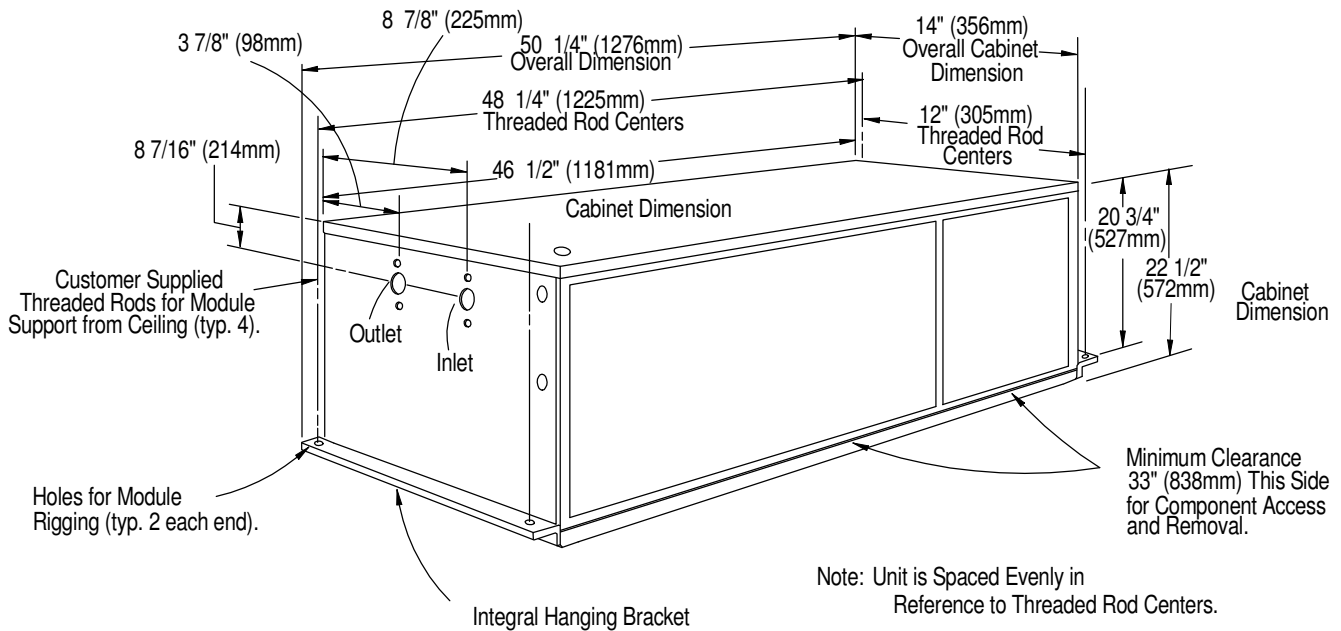

DIMENSIONAL DATA

Model #	Unit Net Weight lbs. (kg)	Refrigerant Connection Sizes O.D. Cu	
		Suction	Liquid
60 Hz			
MC*26W	175 (79)	5/8"	3/8"

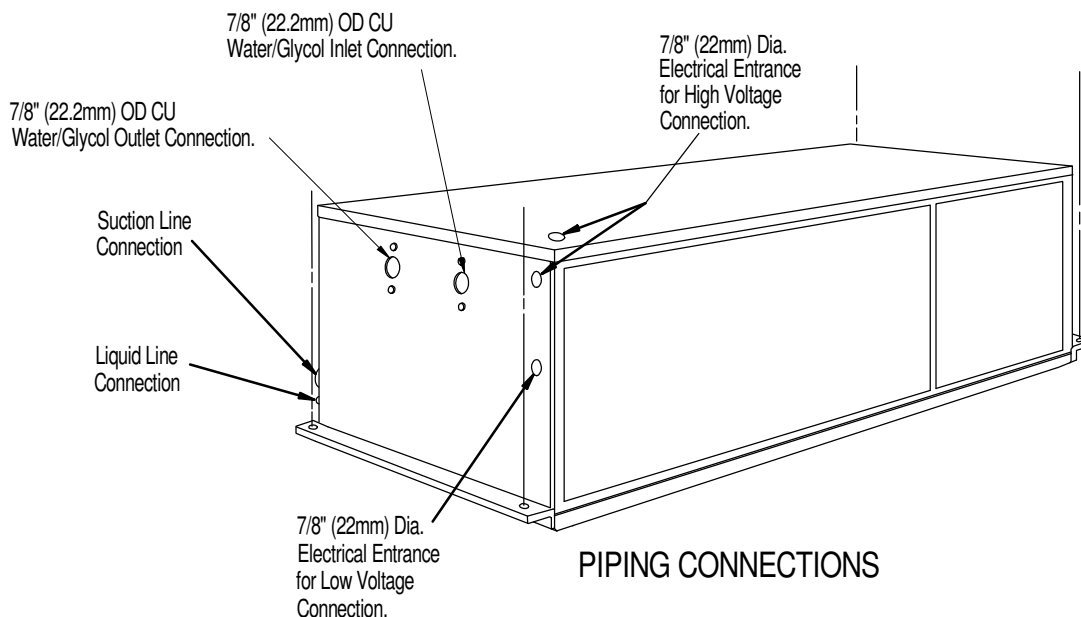

PRIMARY CONNECTION LOCATIONS WATER/GLYCOL CONDENSING UNIT

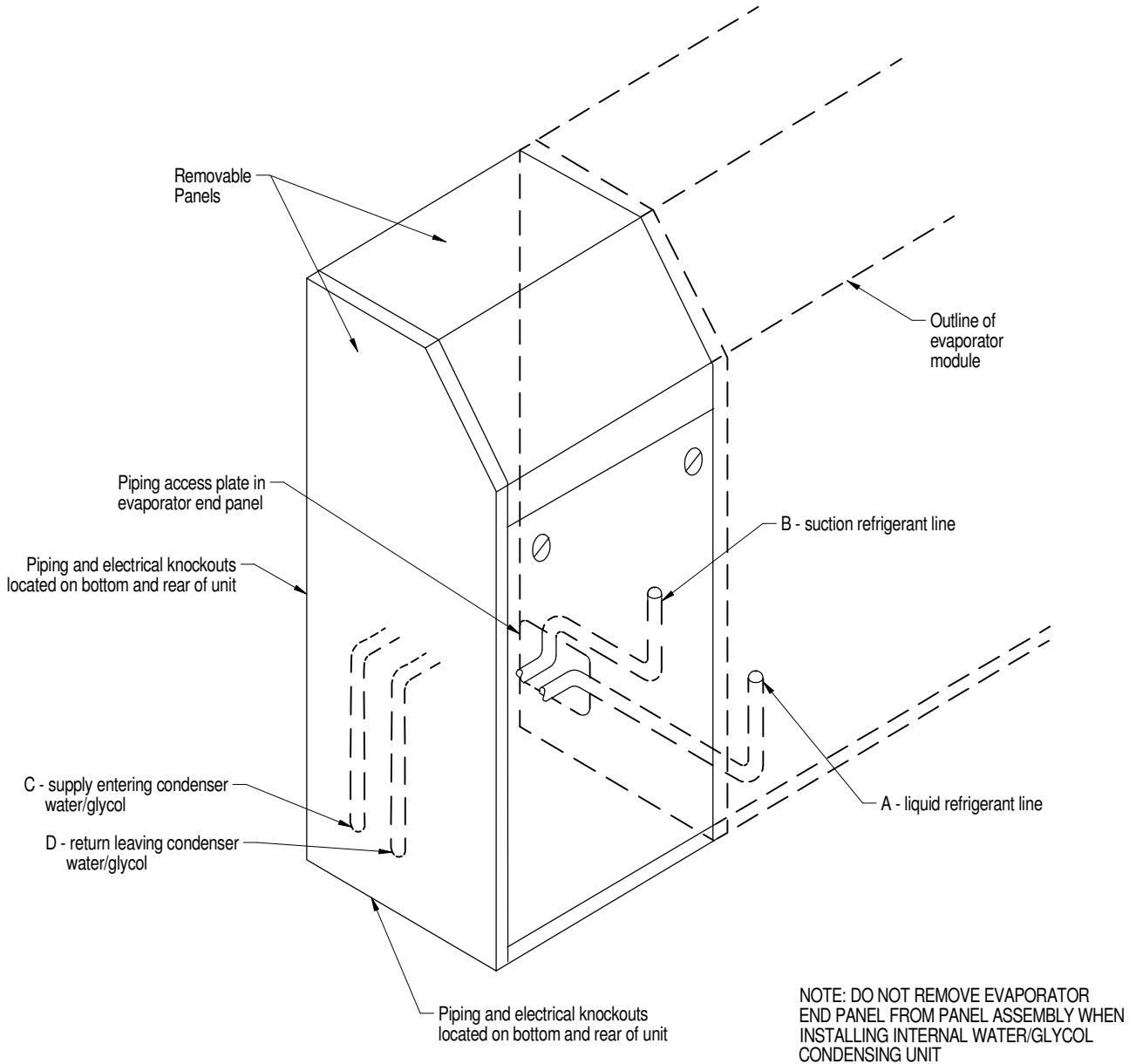

MODEL NUMBER	UNIT REFRIGERANT CONNECTION SIZES O.D. CU		WATER/GLYCOL PIPING CONNECTION SIZES O.D. CU	
	LIQUID LINE	SUCTION LINE	SUPPLY	RETURN
	A	B	C	D
DMC022WG	3/8"	5/8"	5/8"	5/8"
DMC029WG		7/8"	7/8"	7/8"
DMC040WG				

PRIMARY CONNECTION LOCATIONS CONDENSING UNIT W/ HORIZONTAL AIR DISCHARGE

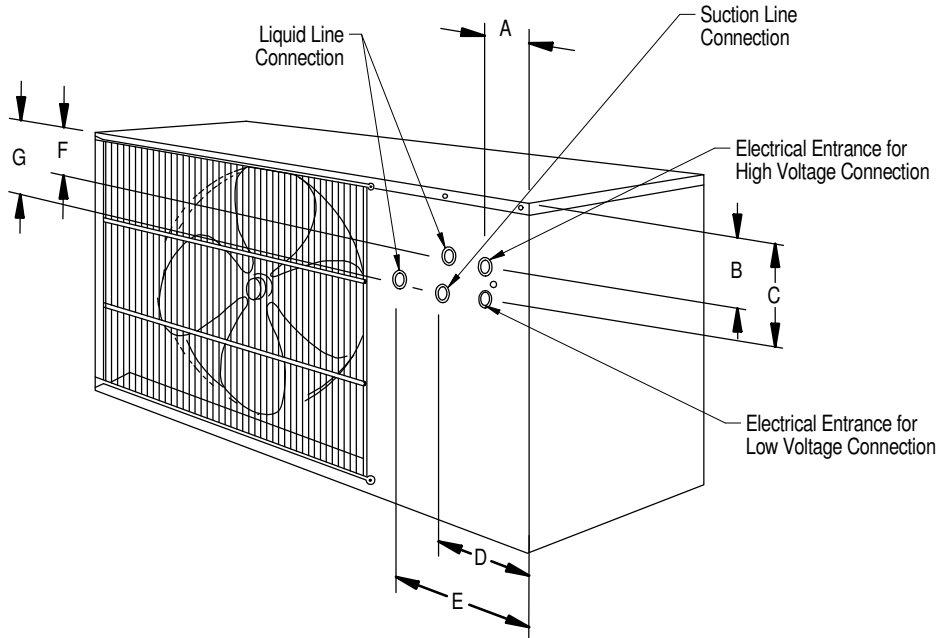

MODEL NUMBERS		ELECTRICAL CONNECTIONS INCH (MM)			PIPING CONNECTION LOCATION INCH (MM)				PIPING CONNECTION SIZES O.D. CU	
60Hz	50Hz	A	B	C	D	E	F	G	Liquid	Suction
PFH014A-L	N/A	2-1/4 (57)	5-1/4 (133)	7-3/4 (197)	8-3/4 (222)	N/A	5 (127)	7-1/4 (184)	3/8"	5/8"
PFH020A-L	N/A		5-3/4 (146)	8-1/2 (216)	4-3/4 (12)	N/A	8-1/2 (216)	1/2"		
PFH027A-L	N/A								2 (51)	6 (152)
PFH027A-H	N/A									
PFHZ27A-L	N/A									
PFH037A-L	PFH036A-L									
PFH042A-L	PFH041A-L									
PFH037A-H	PFH036A-H									
PFHZ37A-L	PFHZ36A-L									
PFH042A-H	PFH041A-H									
PFHZ42A-L	PFHZ41A-L									
PFH067A-L	PFH066A-L									

ELECTRICAL FIELD CONNECTIONS FAN/COIL & CHILLED WATER SYSTEMS

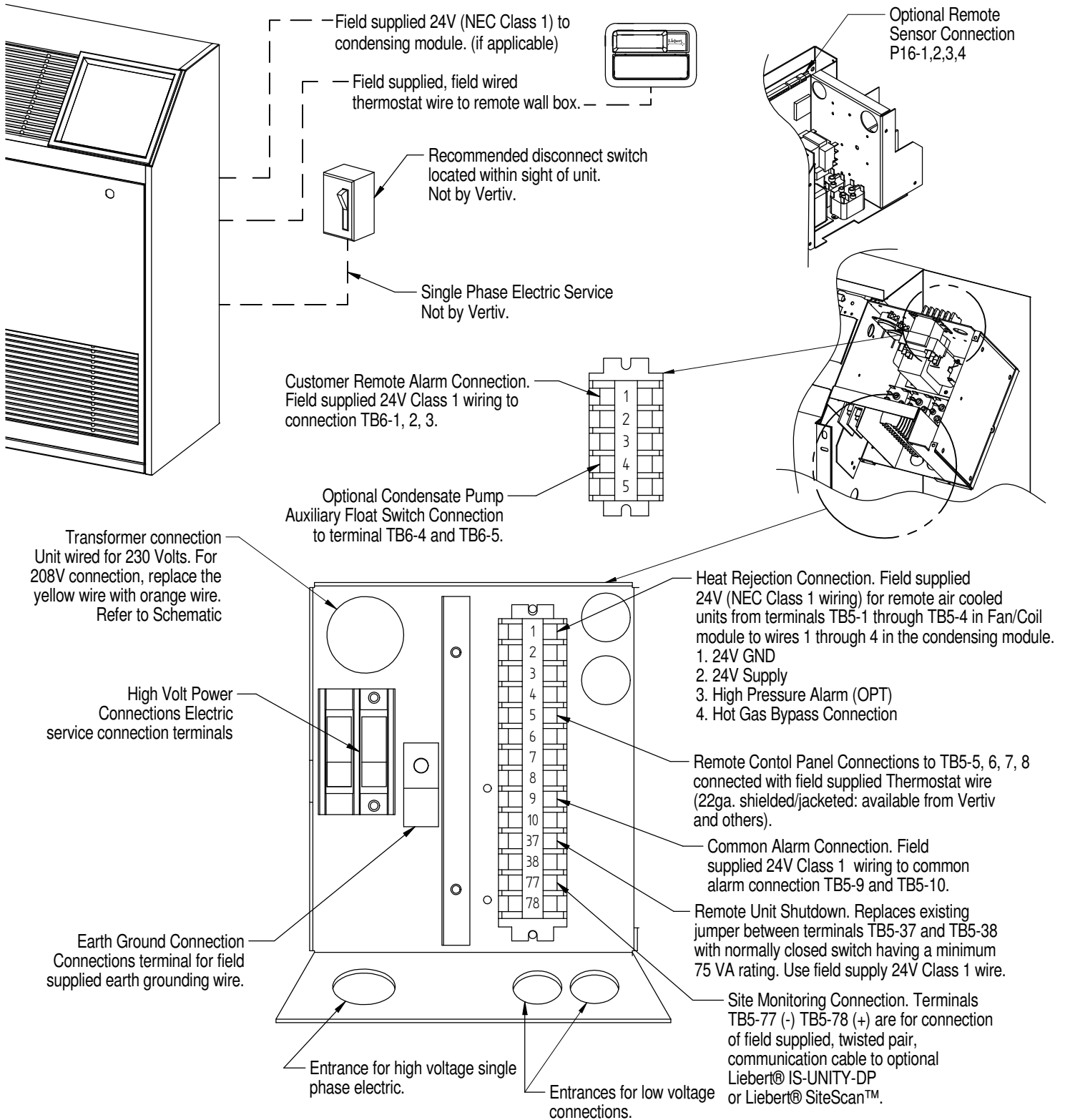

NOTE: Refer to specification sheet for full load amp. and wire size amp. ratings.

ELECTRICAL FIELD CONNECTIONS WATER/GLYCOL COOLED MODELS

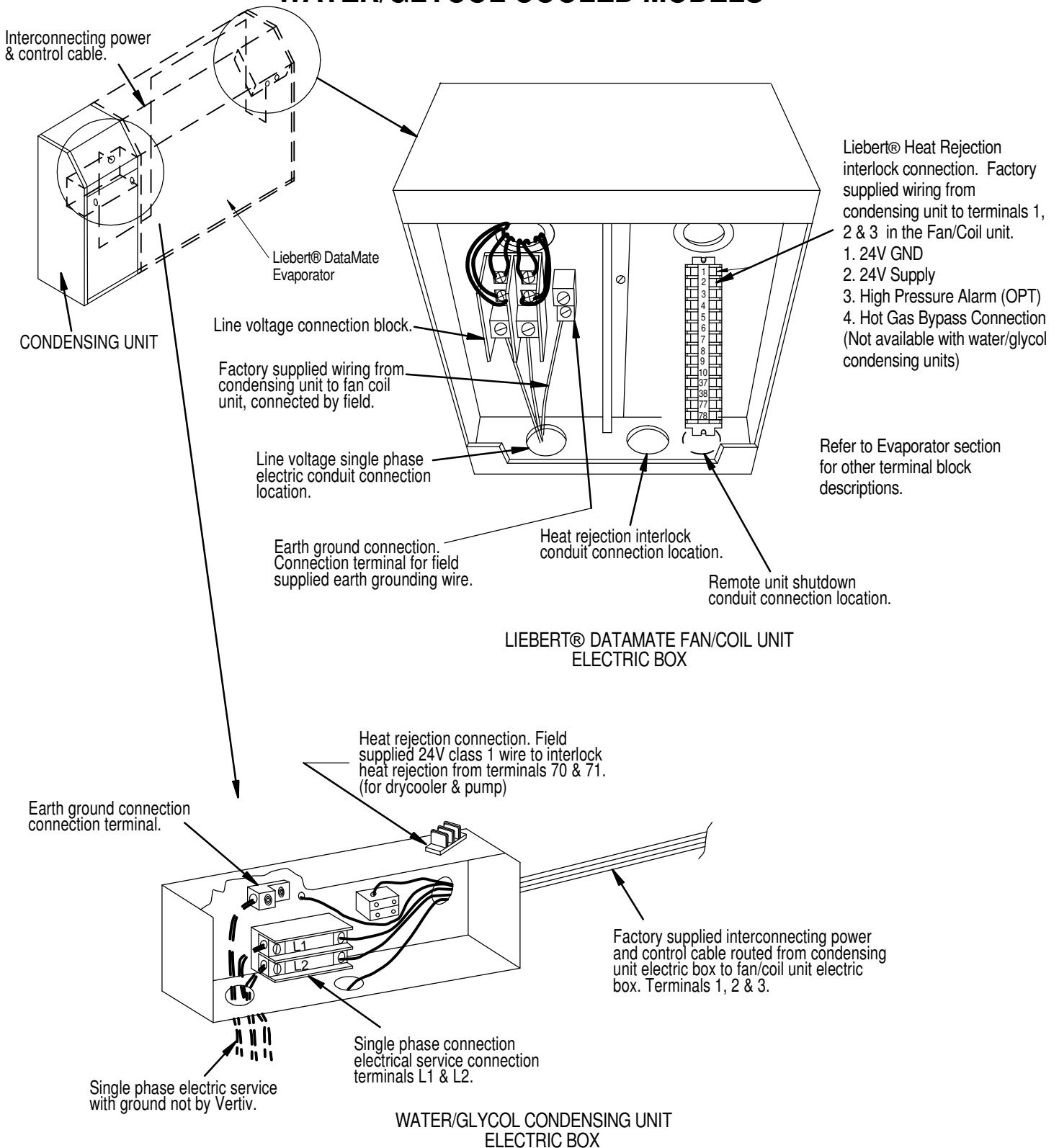

NOTE: Refer to specification sheet for full load amp. and wire size amp. ratings.

GENERAL ARRANGEMENT & DIMENSIONAL DATA WALL MOUNTED LIEBERT® IS-UNITY-DP CARD FOR BMS CONNECTIVITY

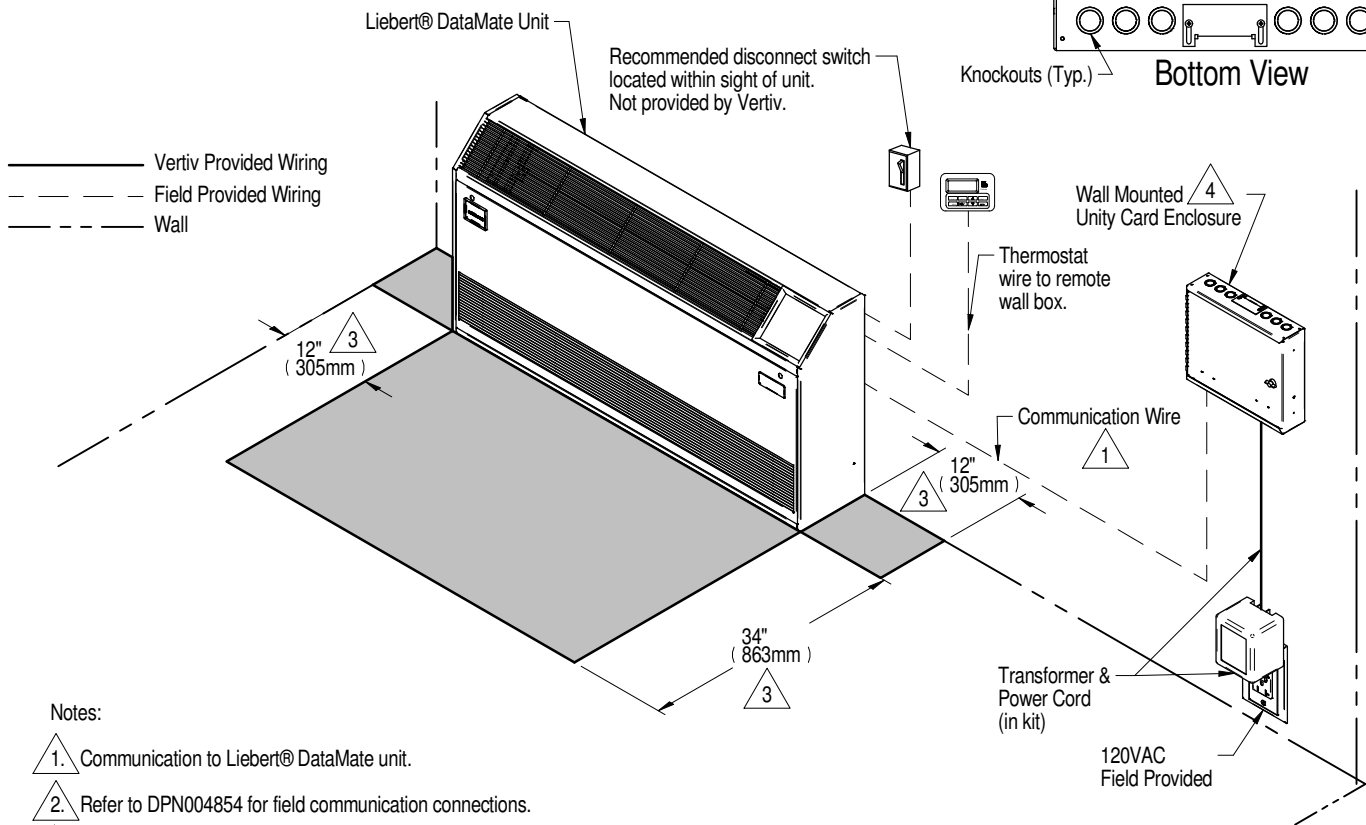
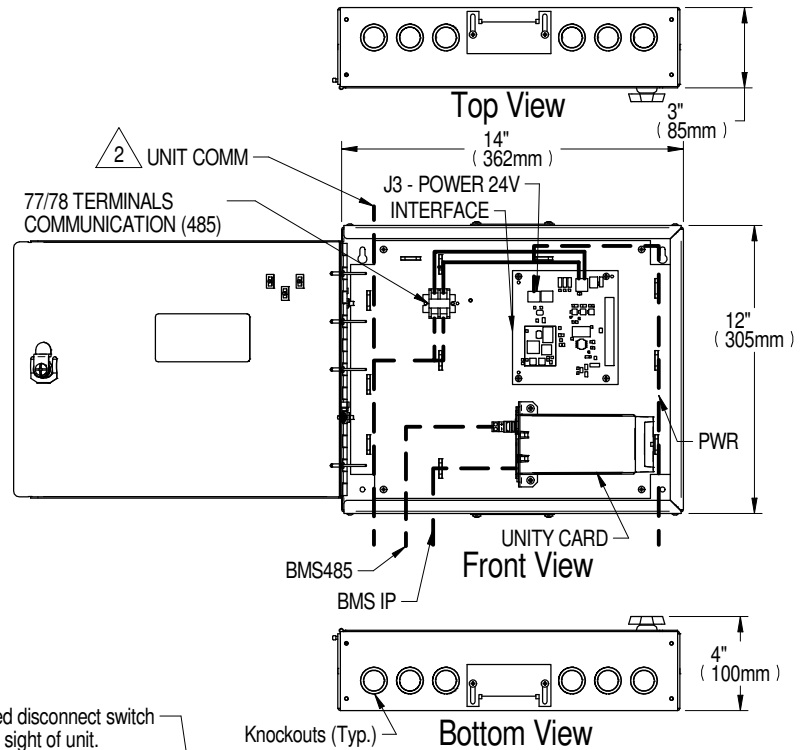

BMS COMMUNICATION CONNECTION OPTIONS LIEBERT® MINI-MATE2 & LIEBERT® DATAMATE

BMS IP/485
(1 Cooling Unit only)

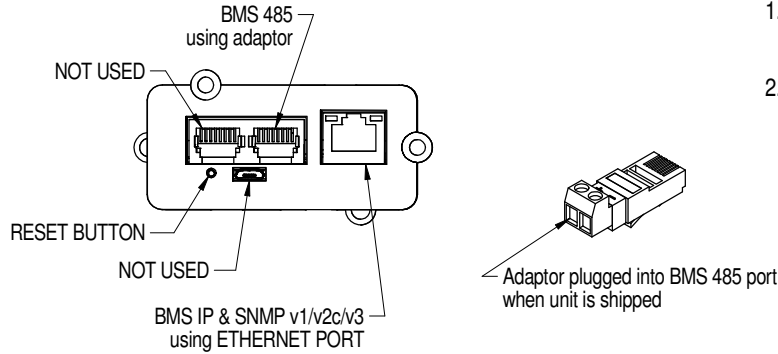

1. Building Management System (BMS) Protocols
 - *BACNet over IP/485
 - *Modbus over IP/485
2. Communication wiring is field supplied
 - IP - use CAT5e cable or greater
 - 485 - use EIA 485 rated, shielded, twisted pair cable, 22-18AWG.
 - Must be rated to meet local codes and conditions.

UNIT TO INTERFACE BOARD CONNECTIONS

	UNIT		UNIT MOUNTED KITS*		WALL MOUNTED KITS**	
	TERMINAL/PLUG	POSITION	TERMINAL/PLUG	POSITION	TERMINAL/PLUG	POSITION
Liebert® Mini-Mate2 1-5 Ton						
COMMUNICATION (485)	TB4	1 / 2	J2	2 / 1	77 / 78	N/A
POWER 24V	20, 21	N/A	J3	1 / 2	J3	1 / 2
Liebert® Mini-Mate2 8 Ton						
COMMUNICATION (485)	77, 78	N/A	J2	2 / 1	77 / 78	N/A
POWER 24V	TB1	4 / 8	J3	1 / 2	J3	1 / 2
Liebert® DataMate						
COMMUNICATION (485)	TB5	77 / 78	N/A	N/A	77 / 78	N/A
POWER 24V	N/A	N/A	N/A	N/A	J3	1 / 2

Notes

Terminals are presented in order of connection. For example, TB4-1 connects to J2-2.

* Unit mounted kits are provided with Unit Comm & power wire harnesses; BMS Comm are field provided.

** Wall mounted kits are provided with power wire harness and 120 Volt wall outlet transformer. Unit Comm & BMS Comm are field provided.

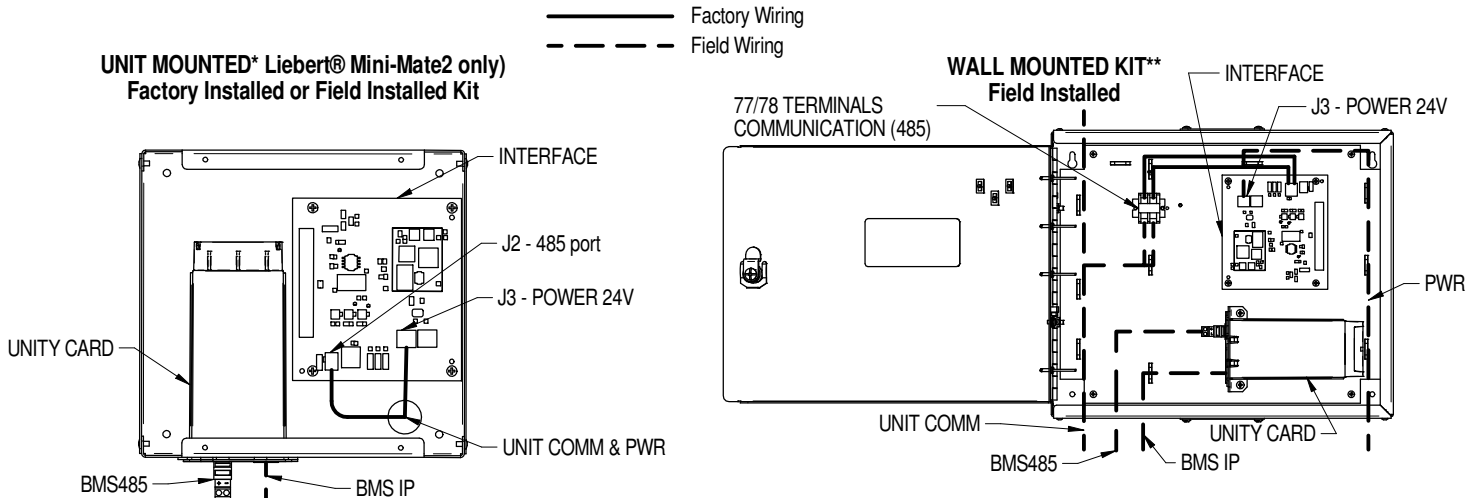

ELECTRICAL FIELD CONNECTIONS 2 TON AIR COOLED INDOOR CONDENSING MODULE

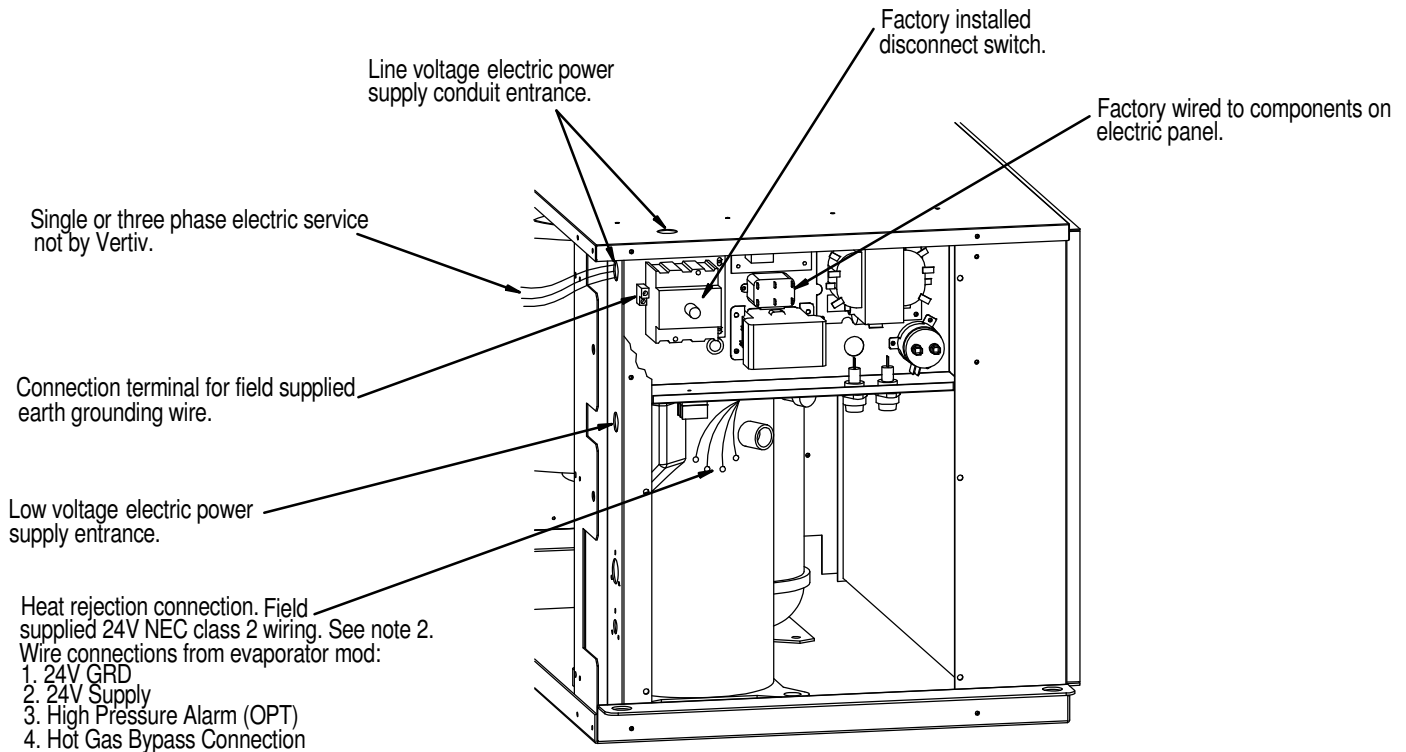
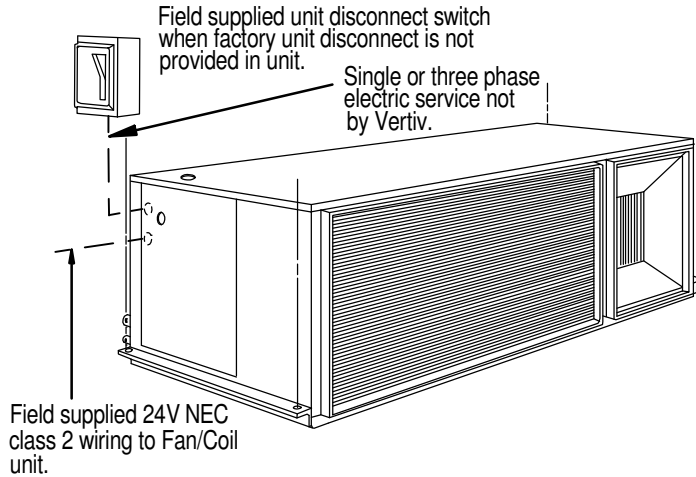

Left End View

NOTES:

1. Refer to specification sheet for full load amp and wire size amp. ratings.
2. Control voltage wiring must be a minimum of 16GA (1.3mm) for up to 75'(23m) or not to exceed 1 volt drop in control line.

ELECTRICAL FIELD CONNECTIONS

2 TON WATER/GLYCOL COOLED INDOOR CONDENSING MODULE

Single or three phase electric service not by Vertiv



Field supplied unit disconnect switch when factory unit disconnect is not provided in unit.

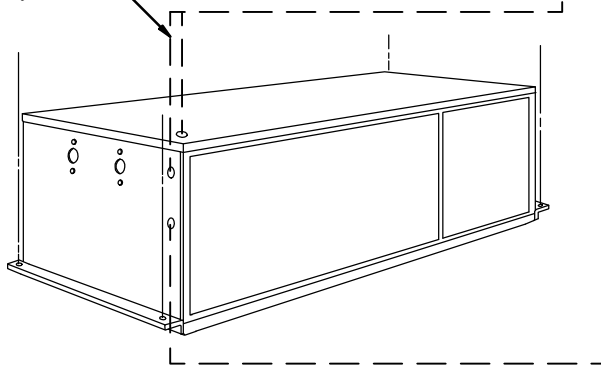

- Field supplied 24V NEC class 1 wiring to Fan/Coil unit.
- Field supplied 24V NEC class 1 wiring to Liebert® Drycooler (Glycol cooled units only).

Earth ground connection.
Connection terminal for field supplied earth grounding wire.

Line voltage electric power supply entrance.

Factory wired to components on electric panel.

Optional factory installed disconnect switch.

Low voltage electric power supply entrance.

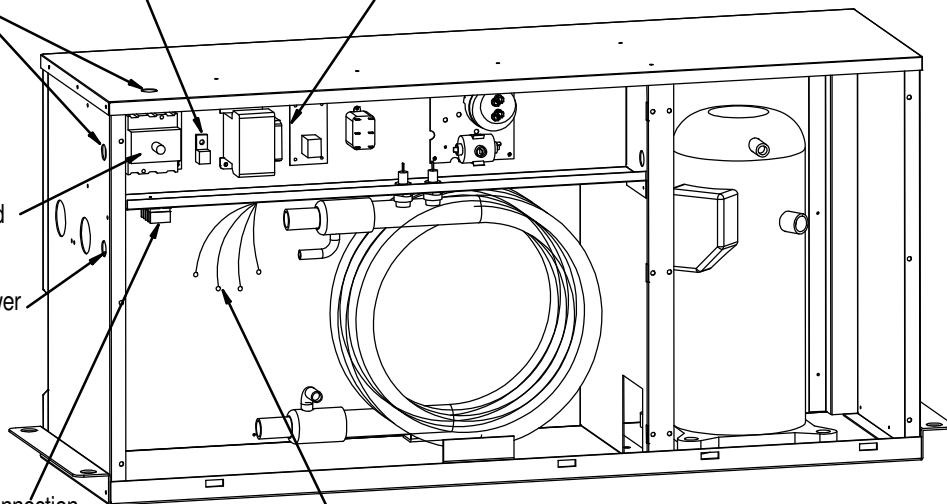

Remote Liebert® Drycooler connection.
Terminals 70 & 71 supplied for connection to remote Liebert® Drycooler, use field supplied 24V NEC class 1 wiring (Glycol cooled units only).

Heat Rejection Connection.
Field supplied 24V NEC class 2 wiring. See note 2.
Wire connections from evaporator mod:
1. 24V GND
2. 24V Supply
3. High Pressure Alarm (OPT)
4. Hot Gas Bypass Connection

NOTES:

1. Refer to specification sheet for full load amp and wire size amp ratings.
2. Control voltage wiring must be a minimum of 16GA (1.3mm) for up to 75' (23m) or not to exceed 1 volt drop in control line.

Connect with Vertiv on Social Media



<https://www.facebook.com/vertiv/>



<https://www.instagram.com/vertiv/>



<https://www.linkedin.com/company/vertiv/>



<https://www.twitter.com/Vertiv/>



Vertiv.com | Vertiv Headquarters, 505 N. Cleveland Ave., Westerville, OH 43082 USA

© 2023 Vertiv Group Corp. All rights reserved. Vertiv™ and the Vertiv logo are trademarks or registered trademarks of Vertiv Group Corp. All other names and logos referred to are trade names, trademarks or registered trademarks of their respective owners. While every precaution has been taken to ensure accuracy and completeness here, Vertiv Group Corp. assumes no responsibility, and disclaims all liability, for damages resulting from use of this information or for any errors or omissions.

SL-11035_REV14_05-23