



# Liebert® CRV

## System Design Catalog

Row-Based Cooling System - 600-mm and 300-mm Wide,  
Air-cooled, Water/Glycol-cooled and Chilled-water-cooled Units; 60 Hz

The information contained in this document is subject to change without notice and may not be suitable for all applications. While every precaution has been taken to ensure the accuracy and completeness of this document, Vertiv assumes no responsibility and disclaims all liability for damages resulting from use of this information or for any errors or omissions.

Vertiv recommends installing a monitored fluid detection system that is wired to activate the automatic closure of field-installed coolant fluid supply and return shut off valves, where applicable, to reduce the amount of coolant fluid leakage and consequential equipment and building damage. Refer to local regulations and building codes relating to the application, installation, and operation of this product. The consulting engineer, installer, and/or end user is responsible for compliance with all applicable laws and regulations relating to the application, installation, and operation of this product.

The products covered by this instruction manual are manufactured and/or sold by Vertiv. This document is the property of Vertiv and contains confidential and proprietary information owned by Vertiv. Any copying, use, or disclosure of it without the written permission of Vertiv is strictly prohibited.

Names of companies and products are trademarks or registered trademarks of the respective companies. Any questions regarding usage of trademark names should be directed to the original manufacturer.

### **Technical Support Site**

If you encounter any installation or operational issues with your product, check the pertinent section of this manual to see if the issue can be resolved by following outlined procedures.

Visit <https://www.Vertiv.com/en-us/support/> for additional assistance.

# TABLE OF CONTENTS

<b>1 Nomenclature and Components</b> .....	<b>1</b>
1.1 Model Number Nomenclature .....	1
1.2 Component Location .....	1
1.3 Cooling Configurations and Vertiv™ Liebert® CRV Overview .....	2
<b>2 System Data</b> .....	<b>5</b>
2.1 Air Cooled System Performance and Physical Data .....	5
2.1.1 Operating Limits for Air Cooled Systems .....	7
2.1.2 Sound Data for Air Cooled Systems .....	7
2.2 Water Cooled System Performance and Physical Data .....	9
2.3 Glycol Cooled System Performance and Physical Data .....	10
2.3.1 Operating Limits for Water/Glycol Systems .....	13
2.3.2 Sound Data for Water/Glycol Systems .....	13
2.4 Chilled Water System Performance and Physical Data .....	15
2.4.1 Operating Limits for Chilled Water Systems .....	18
2.4.2 Sound Data for Chilled Water Systems .....	19
<b>3 Electrical Power Requirements</b> .....	<b>21</b>
3.1 Air Cooled Systems Electrical Data .....	21
3.2 Water/Glycol Systems Electrical Data .....	22
3.3 Chilled Water Systems Electrical Data .....	23
3.4 Electrical Field Connections .....	24
<b>4 Dimensions and Weights</b> .....	<b>25</b>
4.1 Unit Weights .....	25
4.2 Planning Dimensions .....	25
<b>5 Piping Connections</b> .....	<b>27</b>
5.1 Refrigerant Line Sizes and Equivalent Lengths .....	28
<b>6 Heat Rejection—Vertiv™ Liebert® MC Condensers</b> .....	<b>29</b>
6.1 Vertiv™ Liebert® MC Match-up Selections .....	29
6.2 Electrical Power Requirements .....	30
6.2.1 Condenser and Options Net Weights .....	31
6.3 Vertiv™ Liebert® MC Planning Dimensions .....	33
6.4 Vertiv™ Liebert® MC Piping .....	33
6.5 Vertiv™ Liebert® MC Electrical Field Connections .....	34
<b>7 Heat Rejection—Vertiv™ Liebert® Drycoolers and Pumps</b> .....	<b>35</b>
7.1 Liebert® Drycooler Match-up Selections .....	35
7.2 Vertiv™ Liebert® Drycooler Electrical Power Requirements .....	37
7.3 Vertiv™ Liebert® Drycooler Planning Dimensions .....	37
7.4 Vertiv™ Liebert® Drycooler Piping Guidelines .....	38
7.5 Vertiv™ Liebert® Drycooler Electrical Field Connections .....	38

7.6 Vertiv™ Liebert® Drycooler Pump Packages ..... 38

    7.6.1 Vertiv™ Liebert® Drycooler Expansion Tank ..... 39

    7.6.2 Compression Tank ..... 40

**Appendices ..... 41**

Appendix A: Technical Support and Contacts ..... 41

Appendix B: Model Number Nomenclature Detail ..... 43

Appendix C: Optional Configuration for Vertiv™ Liebert® CRV Seismic Application ..... 47

Appendix D: Optional Configuration for Vertiv™ Liebert® CRV Non-seismic Application ..... 49

Appendix E: Vertiv™ Liebert® CRV Intended Application ..... 51

Appendix F: Extra Airflow—Standard on 600 Series, Configurable on 300 Series ..... 63

Appendix G: Guide Specifications ..... 65

Appendix H: Submittal Drawings ..... 67

# 1 Nomenclature and Components

This section describes the model number for Vertiv™ Liebert® CRV units and components.

## 1.1 Model Number Nomenclature

The tables describe the 25-digit configuration number. The 14-digit model number consists of the first 10 digits and last four digits of the configuration number.

For the full description of configuration and model number refer to [Model Number Nomenclature Detail](#) on page 43.

Model Number Digits 1 to 10										Model Details										Model Number Digits 11 to 14				
1	2	3	4	5	6	7	8	9	10	11	12	13	14	15	16	17	18	19	20	21	22	23	24	25
C	R	0	3	5	R	A	1	C	7	S	H	1	8	1	1	P	L	U	O	P	A	#	#	#

Digit and Description	
Digits 1-2 - Unit Family	Digit 14 - Air Filter
Digits 3-5 - Nominal Capacity, kW	Digit 15 - Water/Glycol Valve Type
Digit 6 - Row Based, Unit Depth	Digit 16 - Enclosure
Digit 7 - System Type	Digit 17 - High Voltage Options
Digit 8 - Fan Type	Digit 18 - Option Package
Digit 9 - Power Supply	Digit 19 - Liebert® IntelliSlot™™ Housing
Digit 10 - Cooling System	Digit 20 - Future Options
Digit 11 - Humidifier	Digit 21 - Packaging With Ramp
Digit 12 - Control System	Digit 22 - Factory Configuration Code
Digit 13 - Reheat	Digits 23-25 - Factory Configuration Number

## 1.2 Component Location

The unit component locations are described in the submittal documents included in the [Submittal Drawings](#) on page 67.

The following table lists the relevant documents by number and title.

**Table 1.1 Component Location Drawings**

Document Number	Title
DPNO03738	Component Locations, 600mm (24 in.) Models
DPNO03583	Component Location, 300mm (12 in.) Air Cooled Models
DPNO03585	Component Location, 300mm (12 in.) Water Glycol Cooled Models
DPNO03584	Component Location, 300mm (12 in.) Chilled Water Models

### 1.3 Cooling Configurations and Vertiv™ Liebert® CRV Overview

The Liebert® CRV is a precision cooling unit available in compressorized (air, water or glycol cooled) and chilled water configurations to be installed within a row of high-density computing racks in a hot aisle-cold aisle configuration.

Air enters the rear of the Liebert® CRV from the hot aisle, is filtered, cooled and conditioned, then discharged into the cold aisle. The Liebert® CRV provides all the necessary functions of a standard thermal management unit, including cooling, heating, humidification, dehumidification, air filtration, condensate management, temperature control, alarm monitoring and data communication. (The 300 mm [12 inch] models do not provide heating, humidification, or dehumidification.) The CRV is optimized for maximum cooling capacity in a minimal footprint.

The Liebert® CRV 300 series and 600 series thermal management units are meant for location within a row of heat generating IT equipment racks.

The Liebert® CRV is optimized for maximum cooling capacity in a minimal footprint. The extremely energy efficient components of the system are managed by the Liebert® iCOM™ control system. The environment is monitored in real time by the Liebert® iCOM™ control through sensors positioned in a variety of locations. Sensors located in the return air, supply air and rack inlets allow the unit to optimize its operations for both performance and energy efficiency.

All operations and sensor data can be reported remotely via a variety of communication protocols, providing a built-in rack temperature monitoring system.

The supply air baffle directs the air leaving the Liebert® CRV to the racks, maximizing its effectiveness, reducing the chance for hot spots, and improving overall system efficiency. The angle and spacing of the baffle vanes series are optimized through CFD modeling, laboratory testing, and real world installations.

All service and maintenance is performed through the front and rear of the unit, including all component replacement. All piping and electrical connections are made through the top or bottom of the unit.

**Table 1.2 Liebert® CRV Configurations**

Series	Width	Cooling Type	Nominal Cooling Capacity, kW	Input Power 60 Hz
600	24 in. (600 mm)	Air	20	208 V/3 ph 460 V/3 ph
		Water/Glycol		
		Air	35	
		Water/Glycol		
		Chilled Water		
300	12 in. (300 mm)	Air	19	208-230 V/3 ph 460 V/3 ph-Wye
		Chilled Water	32	208-230 V/1 ph
				208-230 V/3 ph
				460 V/3 ph-Wye 120 V/1 ph
Water/Glycol	19	208-230 V/3 ph 460 V/3 ph-Wye		

The Vertiv™ Liebert® CRV standard and optional features are described in the submittal documents included in the [Submittal Drawings](#) on page 67 .

The following table lists the relevant documents by number and title.

**Table 1.3 Standard and Optional Feature Submittals**

Document Number	Title
<b>Air Cooled 600 mm (24 in.) Models</b>	
DPN001904	Standard Features
DPN001907	Optional Features
<b>Air Cooled 300 mm (12 in.) Models</b>	
DPN002811	Standard Features
DPN002812	Optional Features
<b>Water/Glycol Cooled 600 mm (24 in.) Models</b>	
DPN001905	Standard Features
DPN001908	Optional Features
<b>Water/Glycol Cooled 300 mm (12 in.) Models</b>	
DPN003037	Standard Features
DPN003038	Optional Features
<b>Chilled Water Cooled 600 mm (24 in.) Models</b>	
DPN001906	Standard Features
DPN001909	Optional Features
<b>Chilled Water Cooled 300 mm (12 in.) Models</b>	
DPN002974	Standard Features
DPN002973	Optional Features

This page intentionally left blank



## 2 System Data

### 2.1 Air Cooled System Performance and Physical Data

Table 2.1 Air Cooled Data - 60 Hz Models

Model Size		CR019RA	CR020RA	CR035RA
Return Air Conditions	Width, mm (In.)	300 (12)	600 (24)	
<b>DX Evaporator - Net Capacity Data at 95°F (35°C) Outdoor Ambient</b>				
Liebert MC Matchup at 95°F (35°C) Outdoor Ambient		MCS028	MCS028	MCM040
105°F DB, 70.7°F WB, 52°F DP, 17% RH (40.6°C DB, 21.5°C WB)	Total, kW (BTUH)	21.8 (74,400)	25.2 (86,000)	40.0 (136,500)
	Sensible, kW (BTUH)	21.8 (74,400)	25.2 (86,000)	40.0 (136,500)
100°F DB, 69.2°F WB, 52°F DP, 20% RH (37.8°C DB, 20.7°C WB)	Total, kW (BTUH)	20.9 (71,300)	24.1 (82,200)	38.4 (131,000)
	Sensible, kW (BTUH)	20.9 (71,300)	24.1 (82,200)	38.4 (131,000)
95°F DB <sup>1</sup> , 67.7°F WB, 52°F DP, 23% RH (35°C DB, 19.8°C WB)	Total, kW (BTUH)	20.0 (68,200)	23.0 (78,500)	36.7 (125,200)
	Sensible, kW (BTUH)	20.0 (68,200)	23.0 (78,500)	36.7 (125,200)
90°F DB, 66.1°F WB, 52°F DP, 27% RH (32.2°C DB, 18.9°C WB)	Total, kW (BTUH)	19.0 (64,800)	22.1 (75,400)	35.4 (120,800)
	Sensible, kW (BTUH)	18.9 (64,500)	21.9 (74,700)	34.5 (117,700)
85°F DB, 64.4°F WB, 52°F DP, 32% RH (29.4°C DB, 18°C WB)	Total, kW (BTUH)	18.3 (62,400)	21.4 (73,000)	34.4 (117,400)
	Sensible, kW (BTUH)	17.6 (60,100)	20.1 (68,600)	31.7 (108,200)
80°F DB, 62.7°F WB, 52°F DP, 38% RH (26.7°C DB, 17.1°C WB)	Total, kW (BTUH)	17.7 (60,400)	20.8 (71,000)	33.4 (114,000)
	Sensible, kW (BTUH)	16.1 (54,900)	18.3 (62,400)	28.9 (98,600)
<b>Fan Section</b>				
Return Air Volume, ACFM (ACMH)		2,250 (3,823)	2,510 (4,264)	3,725 (6,329)
Standard Fan Motor, hp (kw)		0.65 (0.48)	.87 (.65)	2.21 (1.65)
Number of Fans		5	2	2
External Static Pressure, in.w.g. (Pa)		0 <sup>1</sup>	0 <sup>1</sup>	0 <sup>1</sup>
<ol style="list-style-type: none"> <li>1. Certified in accordance with the AHRI Datacom Cooling Certification Program at AHRI Standard 1360 (I-P) Standard Rating Conditions. Certified units may be found in the AHRI Directory at <a href="http://www.ahrirectory.org">www.ahrirectory.org</a>.</li> <li>2. Some options or combinations of options may result in reduced air flow. Consult factory for recommendations.</li> <li>3. Data rated at 100% fan speed and with Standard Feature filter (MERV1 for 300 mm and MERV8 for 600 mm).</li> <li>4. Net capacity data has fan motor heat factored in for all ratings.</li> <li>5. Consult factory for alternate performance outputs. Performance data generated in LRS Update Version 12/13/2019.</li> </ol>				

**Table 2.2 Physical Data - Air Cooled, 600 mm (24 in.)**

Parameter	CR020RA	CR035RA
<b>Evaporator Coil</b>		
Face Area, ft2 (m2)	7.26 (0.674)	
Rows	4	5
Face Velocity, FPM (m/s)	346 (1.76)	513 (2.61)
<b>Electric Reheat Single Stage</b>		
Capacity, BTU/H (kW)	460 V: 20,472 (6.0) 208 V: 16,719 (4.9)	
<b>Steam Generating Humidifier</b>		
Capacity, lb/hr (kg/hr)	5.0 (2.3)	
Capacity, kW	1.79	
<b>Filter Section - Disposable Type</b>		
	<b>MERV 8 - Standard Pleated Filter</b>	
Number	2	
Nominal Size, in (mm)	31-1/2 x 17-1/2 x 4 (800 x 445 x 100)	
Effective Surface Area - ft2 (m2)	16.4 (1.52)	
	<b>MERV 11 - Optional Pleated Filter</b>	
Quantity	2	
Nominal Size, in (mm)	31-1/2 x 17-1/2 x 4 (800 x 445 x 100)	
Effective Surface Area - ft2 (m2)	16.4 (1.52)	

**Table 2.3 Physical Data—Air Cooled, 300 mm (12 in.)**

System	CR019RA	
	DX	
<b>Evaporator Coil</b>		
Face Area, ft2 (m2)	6.46 (0.6)	
Rows	3	
Face Velocity, FPM (m/s)	348 (1.77)	
<b>Filter Section—MERV 1, Washable Type</b>		
Quantity	2	
Nominal Size, in. (mm)	35.5 x 10.6 x 0.4 (902 x 269 x 10)	
Effective Surface Area, ft2 (m2)	2.3 (0.21)	

## 2.1.1 Operating Limits for Air Cooled Systems

The Vertiv™ Liebert® CRV operates within the working ranges in [Operating limits—Air Cooled Systems](#) below. These limits refer to new units and those that have been correctly installed and serviced.

**Table 2.4 Operating limits—Air Cooled Systems**

Parameter		Design Condition	
		Minimum	Maximum
Unit Entering Air Conditions	Temperature	75°F (23.9°C)	110°F(43.3°C)
	Relative Humidity	15%	60%
Storage Conditions	Temperature	-4°F (-20°C)	122°F (50°C)
Power Supply Tolerances		Voltage ± 10%	
		Frequency ±2Hz	

## 2.1.2 Sound Data for Air Cooled Systems

**Table 2.5** below, and **Table 2.6** on the next page, show the sound pressure level in free field at 5 feet (1.5 m) high and 6-1/2 feet (2 m) in front of the air conditioner, with compressor and fan in operation. The sound data is without the Low Sound Package compressor jacket and sound deadening panel insulation installed.

Sound power is an absolute measurement that can be used for comparisons when all sound measurement parameters match exactly.

**Table 2.5 Sound Data—CR020RA and CR035RA**

Model Type			Air Cooled CR020RA, 600 mm (24 in.) with 2 Fans with Filter			Air Cooled, CR035RA, 600 mm (24 in.) with 2 Fans with Filter		
Factory Fan Speed %			100	75	55	100	75	50
Airflow	SCFM		2168	1618	1180	2777	2070	1370
	m3/h		3683	2749	2005	4718	3517	2327
Sound Power Level (PWL)	Octave Band Frequency (Hz)	31.5 dB	73.8	71.2	67.6	76	71.3	66.3
		63 dB	69.4	66.8	63.2	76.2	71.5	66.5
		125 dB	71	68.4	64.8	80.5	75.8	70.8
		250 dB	77.3	74.7	71.1	82.7	78	73
		500 dB	75.9	73.3	69.7	77.3	72.6	67.6
		1000 dB	74.2	71.6	68	73.1	68.4	63.4
		2000 dB	73.5	70.9	67.3	74.5	69.8	64.8
		400 dB	68.2	65.6	62	69	64.3	59.3
		8000 dB	59.2	56.6	53	61.9	57.2	52.2
		A-Scale Weighted, dB (A)		79.6	77	73.4	80.9	76.2
Sound Pressure Level (SPL)	At Suction Side, 2 m Distance, Free Field Conditions (2m, f.f, dBA)		69.2	66.9	63.9	70	65.7	61.9

**Table 2.6 Sound Data—CR019RA**

Model Type		Air Cooled CR019RA, 300 mm (12 in.) with 5 Fans with Filter			
Fan Speed %		100	75	50	
Sound Power Level (PWL)	Airflow	SCFM	2610	2216	1615
		m3/h	4435	3765	2744
	Octave Band Frequency (Hz)	31.5 dB	—	—	—
		63 dB	—	—	—
		125 dB	72.2	69.7	71.1
		250 dB	82.3	79.0	66.1
		500 dB	81.5	79.1	67.2
		1000 dB	81.2	77.4	65.1
		2000 dB	78.1	73.9	59.5
		4000 dB	70.2	65.9	55.2
8000 dB		64.7	62.3	51.8	
A-Scale Weighted, dB(A)		85.4	81.6	69.4	
Sound Pressure Level (SPL)	Inlet, dB(A)		76.7	72.7	62.0
	Outlet, dB(A)		82.6	79.9	70.2
	At Suction Side, 2 m Distance, 1.5 m Above Ground, Free Field Conditions (2 m, f.f, dBA)		65.7	61.8	51.0
	At Discharge Side, 2 m Distance, 1.5 m Above Ground, Free Field Conditions (2 m, f.f, dBA)		71.6	68.9	59.2

Normal operation of unit at 208- 230 V/3 ph/60 Hz

## 2.2 Water Cooled System Performance and Physical Data

Table 2.7 Water Cooled Data - 60 Hz Models

Model Size		CR019RW	CR020RW	CR035RW
Return Air Conditions	Width, mm (In.)	300 (12)	600 (24)	
<b>DX Evaporator - Net Capacity Data with 83°F (28.3°C) Entering and 95°F (35°C) Leaving Fresh Water Temperatures</b>				
105°F DB, 70.7°F WB, 52°F DP, 17% RH (40.6°C DB, 21.5° WB)	Total, kW (BTUH)	23.1 (78,800)	26.0 (88,700)	41.3 (140,900)
	Sensible, kW (BTUH)	23.1 (78,800)	26.0 (88,700)	41.3 (140,900)
	Flow Rate, GPM (lps)	16.6 (1.0)	18.3 (1.2)	29.4 (1.9)
	Unit Pressure Drop, ft. of Water (kPa)	35.0 (104.7)	43.0 (128.6)	64.0 (191.4)
	Heat Rejection, kW (BTUH)	29.0 (99,000)	32.1 (109,500)	51.6 (176,100)
100°F DB, 69.2°F WB, 52°F DP, 20% RH (37.8°C DB, 20.7°C WB)	Total, kW (BTUH)	22.1 (75,400)	24.8 (84,600)	39.5 (134,800)
	Sensible, kW (BTUH)	22.1 (75,400)	24.8 (84,600)	39.5 (134,800)
	Flow Rate, GPM (lps)	16.0 (1.0)	17.6 (1.1)	28.4 (1.8)
	Unit Pressure Drop, ft. of Water (kPa)	33.0 (98.7)	40.0 (119.6)	60.0 (179.4)
	Heat Rejection, kW (BTUH)	28.0 (95,500)	30.9 (105,400)	49.8 (169,900)
95°F DB <sup>1</sup> , 67.7°F WB, 52°F DP, 23% RH (35°C DB, 19.8°C WB)	Total, kW (BTUH)	21.1 (72,000)	23.6 (80,500)	37.8 (129,000)
	Sensible, kW (BTUH)	21.1 (72,000)	23.6 (80,500)	37.6 (128,300)
	Flow Rate, GPM (lps)	15.4 (1.0)	16.9 (1.1)	27.3 (1.7)
	Unit Pressure Drop, ft. of Water (kPa)	31.0 (92.7)	37.0 (110.6)	55.0 (164.5)
	Heat Rejection, kW (BTUH)	26.9 (91,800)	29.7 (101,300)	48.1 (164,100)
90°F DB, 66.1°F WB, 52°F DP, 27% RH (32.2°C DB, 18.9°C WB)	Total, kW (BTUH)	20.2 (68,900)	22.7 (77,500)	36.6 (124,900)
	Sensible, kW (BTUH)	19.8 (67,600)	22.2 (75,700)	35.0 (119,400)
	Flow Rate, GPM (lps)	14.9 (0.9)	16.3 (1.0)	26.7 (1.7)
	Unit Pressure Drop, ft. of Water (kPa)	29.0 (86.7)	34.0 (101.7)	53.0 (158.5)
	Heat Rejection, kW (BTUH)	26.0 (88,700)	28.7 (97,900)	46.9 (160,000)
85°F DB, 64.4°F WB, 52°F DP, 32% RH (29.4°C DB, 18°C WB)	Total, kW (BTUH)	19.5 (66,500)	22.0 (75,100)	35.5 (121,100)
	Sensible, kW (BTUH)	18.3 (62,400)	20.4 (69,600)	32.2 (109,900)
	Flow Rate, GPM (lps)	14.4 (0.9)	15.9 (1.0)	26.1 (1.6)
	Unit Pressure Drop, ft. of Water (kPa)	27.0 (80.7)	33.0 (98.7)	51.0 (152.5)
	Heat Rejection, kW (BTUH)	25.3 (86,300)	28 (95,500)	45.8 (156,300)

**Table 2.7 Water Cooled Data - 60 Hz Models (continued)**

Model Size		CR019RW	CR020RW	CR035RW
<b>DX Evaporator - Net Capacity Data with 83°F (28.3°C) Entering and 95°F (35°C) Leaving Fresh Water Temperatures</b>				
80°F DB, 62.7°F WB, 52°F DP, 38% RH (26.7°C DB, 17.1°C WB)	Total, kW (BTUH)	18.8 (64,100)	21.4 (73,000)	34.4 (117,400)
	Sensible, kW (BTUH)	16.8 (57,300)	18.5 (63,100)	29.3 (100,000)
	Flow Rate, GPM (lps)	14.1 (0.9)	15.6 (1.0)	25.5 (1.6)
	Unit Pressure Drop, ft. of Water (kPa)	26.0 (77.7)	31.0 (92.7)	48.0 (143.5)
	Heat Rejection, kW (BTUH)	24.6 (83,900)	27.3 (93,200)	44.7 (152,500)
<b>Fan Section</b>				
Return Air Volume, ACFM (ACMH)		2,250 (3,823)	2,510 (4,264)	3,725 (6,329)
Standard Fan Motor, hp (kw)		0.65 (0.48)	.87 (.65)	2.21 (1.65)
Number of Fans		5	2	2
External Static Pressure, in.w.g. (Pa)		0 <sup>1</sup>	0 <sup>1</sup>	0 <sup>1</sup>
<ol style="list-style-type: none"> <li>1. Certified in accordance with the AHRI Datacom Cooling Certification Program at AHRI Standard 1360 (I-P) Standard Rating Conditions. Certified units may be found in the AHRI Directory at <a href="http://www.ahridirectory.org">www.ahridirectory.org</a>.</li> <li>2. Some options or combinations of options may result in reduced air flow. Consult factory for recommendations.</li> <li>3. Data rated at 100% fan speed and with Standard Feature filter (MERV1 for 300 mm and MERV8 for 600 mm).</li> <li>4. Net capacity data has fan motor heat factored in for all ratings.</li> <li>5. Consult factory for alternate performance outputs. Performance data generated in LRS Update Version 12/13/2019.</li> </ol>				

## 2.3 Glycol Cooled System Performance and Physical Data

**Table 2.8 Glycol Cooled Data - 60 Hz Models**

Model Size		CR019RW	CR020RW	CR035RW
Return Air Conditions	Width, mm (in.)	300 (12)	600 (24)	
<b>DX Evaporator - Net Capacity Data with 104°F (40°C) Entering and 115°F (46.1°C) Leaving 40% Propylene Glycol Temperatures<sup>1</sup></b>				
105°F DB, 70.7°F WB, 52°F DP, 17% RH (40.6°C DB, 21.5°C WB)	Total, kW (BTUH)	21.0 (71,700)	23.6 (80,500)	37.8 (129,000)
	Sensible, kW (BTUH)	21.0 (71,700)	23.6 (80,500)	37.8 (129,000)
	Flow Rate, GPM (lps)	19.0 (1.2)	20.8 (1.3)	33.6 (2.1)
	Unit Pressure Drop, ft. of Water (kPa)	52.0 (155.5)	62.0 (185.4)	94.0 (281.1)
	Heat Rejection, kW (BTUH)	28.5 (97,200)	31.2 (106,500)	50.4 (172,000)
100°F DB, 69.2°F WB, 52°F DP, 20% RH (37.8°C DB, 20.7°C WB)	Total, kW (BTUH)	20.0 (68,200)	22.5 (76,800)	36.1 (123,200)
	Sensible, kW (BTUH)	20.0 (68,200)	22.5 (76,800)	36.1 (123,200)
	Flow Rate, GPM (lps)	18.4 (1.2)	20.1 (1.3)	32.5 (2.0)
	Unit Pressure Drop, ft. of Water (kPa)	49.0 (146.5)	58.0 (173.4)	88.0 (263.1)
	Heat Rejection, kW (BTUH)	27.5 (93,800)	30.0 (102,400)	48.6 (165,800)

**Table 2.8 Glycol Cooled Data - 60 Hz Models (continued)**

Model Size		CR019RW	CR020RW	CR035RW
<b>DX Evaporator - Net Capacity Data with 104°F (40°C) Entering and 115°F (46.1°C) Leaving 40% Propylene Glycol Temperatures<sup>1</sup></b>				
95°F DB <sup>1</sup> , 67.7°F WB, 52°F DP, 23% RH (35°C DB, 19.8°C WB)	Total, kW (BTUH)	19.0 (64,800)	21.4 (73,000)	34.4 (117,400)
	Sensible, kW (BTUH)	19.0 (64,800)	21.4 (73,000)	34.4 (117,400)
	Flow Rate, GPM (lps)	17.7 (1.1)	19.3 (1.2)	31.4 (2.0)
	Unit Pressure Drop, ft. of Water (kPa)	46.0 (137.5)	54.0 (161.5)	82.0 (245.2)
	Heat Rejection, kW (BTUH)	26.5 (90,400)	28.9 (98,600)	46.9 (160,000)
90°F DB, 66.1°F WB, 52°F DP, 27% RH (32.2°C DB, 18.9°C WB)	Total, kW (BTUH)	18.1 (61,800)	20.3 (69,300)	32.7 (111,600)
	Sensible, kW (BTUH)	18.1 (61,800)	20.3 (69,300)	32.7 (111,600)
	Flow Rate, GPM (lps)	17.1 (1.1)	18.6 (1.2)	30.2 (1.9)
	Unit Pressure Drop, ft. of Water (kPa)	43.0 (128.6)	50.0 (149.5)	77.0 (230.2)
	Heat Rejection, kW (BTUH)	25.5 (87,000)	27.7 (94,500)	45.2 (154,200)
85°F DB, 64.4°F WB, 52°F DP, 32% RH (29.4°C DB, 18°C WB)	Total, kW (BTUH)	17.2 (58,700)	19.4 (66,200)	31.4 (107,100)
	Sensible, kW (BTUH)	16.9 (57,700)	19.1 (65,200)	30.3 (103,400)
	Flow Rate, GPM (lps)	16.4 (1.0)	17.9 (1.1)	29.4 (1.9)
	Unit Pressure Drop, ft. of Water (kPa)	39.0 (116.6)	47.0 (140.5)	73.0 (218.3)
	Heat Rejection, kW (BTUH)	24.6 (83,900)	26.7 (91,100)	43.9 (149,800)
80°F DB, 62.7°F WB, 52°F DP, 38% RH (26.7°C DB, 17.1°C WB)	Total, kW (BTUH)	16.5 (56,300)	18.8 (64,100)	30.4 (103,700)
	Sensible, kW (BTUH)	15.5 (52,900)	17.3 (59,000)	27.5 (93,800)
	Flow Rate, GPM (lps)	15.9 (1.0)	17.5 (1.1)	28.7 (1.8)
	Unit Pressure Drop, ft. of Water (kPa)	37.0 (110.6)	44.0 (131.6)	69.0 (206.3)
	Heat Rejection, kW (BTUH)	23.8 (81,200)	26.1 (89,100)	42.9 (146,400)
<b>Fan Section</b>				
Return Air Volume, ACFM (ACMH)		2,250 (3,823)	2,510 (4,264)	3,725 (6,329)
Standard Fan Motor, hp (kw)		0.65 (0.48)	.87 (.65)	2.21 (1.65)
Number of Fans		5	2	2
External Static Pressure, in.w.g. (Pa)		0 <sup>1</sup>	0 <sup>1</sup>	0 <sup>1</sup>
<ol style="list-style-type: none"> <li>Rated in accordance with the AHRI Datacom Cooling Certification Program at AHRI Standard 1360 (I-P) Standard Rating Conditions.</li> <li>Some options or combinations of options may result in reduced air flow. Consult factory for recommendations.</li> <li>Data rated at 100% fan speed and with Standard Feature filter (MERV1 for 300mm and MERV8 for 600mm).</li> <li>Net capacity data has fan motor heat factored in for all ratings.</li> <li>Consult factory for alternate performance outputs. Performance data generated in LRS Update Version 12/13/2019.</li> </ol>				

**Table 2.9 Physical Data—Water/Glycol Cooled, 600 mm (24 in.)**

Parameter	CR020RW	CR035RW
<b>Evaporator Coil</b>		
Face Area, ft2 (m2)	7.26 (0.674)	
Rows	4	5
Face Velocity, FPM (m/s)	346 (1.76)	513 (2.61)
<b>Electric Reheat Single Stage</b>		
Capacity, BTU/H (kW)	460 V: 20,472 (6.0) 208 V: 16,719 (4.9)	
<b>Steam Generating Humidifier</b>		
Capacity, lb/hr (kg/hr)	5 (2.3)	
Capacity, kW	1.79	
<b>Filter Section - Disposable Type</b>		
	<b>MERV 8 - Standard Pleated Filter</b>	
Number	2	
Nominal Size, in. (mm)	31-1/2 x 17-1/2 x 4 (800 x 445 x 100)	
Effective Surface Area - ft2 (m2)	16.4 (1.52)	
	<b>MERV 11 - Optional Pleated Filter</b>	
Quantity	2	
Nominal Size, in. (mm)	31-1/2 x 17-1/2 x 4 (800 x 445 x 100)	
Effective Surface Area - ft2 (m2)	16.4 (1.52)	

**Table 2.10 Physical Data—Water/Glycol Cooled, 300 mm (12 in.)**

Parameter	CR019RW
<b>Evaporator Coil</b>	
Face Area, ft2 (m2)	6.46 (0.60)
Rows	3
Face Velocity, FPM (m/s)	348 (1.77)
<b>Filter Section—MERV 1, Washable Type</b>	
Quantity	2
Nominal Size, in. (mm)	35.5 x 10.6 x 0.4 (902 x 269 x 10)
Effective Surface Area, ft2 (m2)	2.3 (0.21)



### 2.3.1 Operating Limits for Water/Glycol Systems

Table 2.11 Operating limits—Water/Glycol Systems

Models	Maximum Water Pressure, psi (kPa)	Maximum Close-Off Pressure, psi (kPa)	Minimum Entering Water Temperature, °F (°C)
			Design Condition
CR019RW, CR020RW, CR035RW	230 (1586)	43.5 (300)	45 (7.2)

### 2.3.2 Sound Data for Water/Glycol Systems

Table 2.12 below, and Table 2.13 on the next page, show the sound pressure level in free field at 5 feet (1.5 m) high and 6-1/2 feet (2 m) in front of the air conditioner, with compressor and fan in operation. The sound data is without the Low Sound Package compressor jacket and sound deadening panel insulation installed.

Sound power is an absolute measurement that can be used for comparisons when all sound measurement parameters match exactly.

Table 2.12 Sound Data—CR020RW and CR035RW

Model Type		Water/Glycol Cooled CR020RW, 600 mm (24 in.) with 2 Fans with Filter			Water/Glycol Cooled, CR035RW, 600 mm (24 in.) with 2 Fans with Filter			
Factory Fan Speed %		100	75	55	100	75	50	
Sound Power Level (PWL)	Airflow	SCFM	2168	1618	1180	2777	2070	1370
		m3/h	3683	2749	2005	4718	3517	2327
	Octave Band Frequency (Hz)	31.5 dB	73.8	71.2	67.6	76	71.3	66.3
		63 dB	69.4	66.8	63.2	76.2	71.5	66.5
		125 dB	71	68.4	64.8	80.5	75.8	70.8
		250 dB	77.3	74.7	71.1	82.7	78	73
		500 dB	75.9	73.3	69.7	77.3	72.6	67.6
		1000 dB	74.2	71.6	68	73.1	68.4	63.4
		2000 dB	73.5	70.9	67.3	74.5	69.8	64.8
		4000 dB	68.2	65.6	62	69	64.3	59.3
8000 dB	59.2	56.6	53	61.9	57.2	52.2		
A-Scale Weighted, dB (A)		79.6	77	73.4	80.9	76.2	71.2	
Sound Pressure Level (SPL)	At Suction Side, 2 m Distance, Free Field Conditions (2m, f.f, dBA)	69.2	66.9	63.9	70	65.7	61.9	

**Table 2.13 Sound Data—CR019RW**

Model Type		Water/Glycol CR019RW, 300 mm (12 in.) with 5 Fans With Filter			
Fan Speed %		100	75	50	
Sound Power Level (PWL)	Airflow	SCFM	2610	2250	1615
		m3/h	4435	3823	2744
	Octave Band Frequency (Hz)	31.5 dB	—	—	—
		63 dB	—	—	—
		125 dB	72.2	70	71.1
		250 dB	82.3	9	66.1
		500 dB	81.5	79	67.2
		1000 dB	81.2	77	65.1
		2000 dB	78.1	74	59.5
		4000 dB	70.2	66	55.2
8000 dB		64.7	62	51.8	
A-Scale Weighted, dB (A)		85.4	82	69.4	
Sound Pressure Level (SPL)	Inlet, dB (A)		76.7	73	62
	Outlet, dB (A)		82.6	80	70.2
	Suction Side 2 m Distance, 1.5 m Above Ground Free Field Conditions (2 m, f.f, dBA)		65.7	62	51
	Discharge Side 2 m Distance, 1.5 m Above Ground Free Field Conditions (2 m, f.f, dBA)		71.6	69	59.2

## 2.4 Chilled Water System Performance and Physical Data

Table 2.14 Performance Data —Chilled Water CR032RC and CR040RC

Model Size		CR032RC		CR040RC	
Return Air Conditions	Width, mm (in)	300 (12)		600 (24)	
Chilled Water Coil - Net Capacity Data at specified Water Temperatures		45°F (7.2°C) EWT- 55°F (12.8°C) LWT	45°F (7.2°C) EWT- 57°F (13.9°C) LWT	45°F (7.2°C) EWT- 55°F (12.8°C) LWT	45°F (7.2°C) EWT- 57°F (13.9°C) LWT
105°F DB, 70.7°F WB, 52°F DP, 17% RH (40.6°C DB, 21.5°C WB)	Total, kW (BTUH)	34.6 (118,100)	32.8 (111,900)	59.5 (203,000)	58.0 (197,900)
	Sensible, kW (BTUH)	33.4 (114,000)	32.5 (110,900)	56.0 (191,100)	55.1 (188,000)
	Flow Rate, GPM (lps)	24.1 (1.5)	19.1 (1.2)	41.6 (2.6)	33.8 (2.1)
	Unit Pressure Drop, ft of Water (kPa)	27 (80.7)	18 (53.8)	50 (149.5)	34 (101.7)
100°F DB, 69.2°F WB, 52°F DP, 20% RH (37.8°C DB, 20.7°C WB)	Total, kW (BTUH)	31.6 (107,800)	29.9 (102,000)	54.5 (186,000)	53.0 (180,800)
	Sensible, kW (BTUH)	30.2 (103,000)	29.3 (100,000)	51.3 (175,000)	50.1 (170,900)
	Flow Rate, GPM (lps)	22.0 (1.4)	17.4 (1.1)	38.3 (2.4)	31.0 (2.0)
	Unit Pressure Drop, ft of Water (kPa)	23 (68.8)	15 (44.9)	43 (128.6)	30 (89.7)
95°F DB1, 67.7°F WB, 52°F DP, 23% RH (35°C DB, 19.8°C WB)	Total, kW (BTUH)	28.3 (96,600)	26.6 (90,800)	49.5 (168,900)	47.8 (163,100)
	Sensible, kW (BTUH)	27.1 (92,500)	26.2 (89,400)	46.3 (158,000)	45.4 (154,900)
	Flow Rate, GPM (lps)	19.8 (1.2)	15.5 (1.0)	34.9 (2.2)	28.1 (1.8)
	Unit Pressure Drop, ft of Water (kPa)	19 (56.8)	12 (35.9)	37 (110.6)	25 (74.8)
90°F DB, 66.1°F WB, 52°F DP, 27% RH (32.2°C DB, 18.9°C WB)	Total, kW (BTUH)	25.1 (85,600)	23.3 (79,500)	44.5 (151,800)	42.5 (145,000)
	Sensible, kW (BTUH)	23.9 (81,600)	23.0 (78,500)	41.3 (140,900)	40.1 (136,800)
	Flow Rate, GPM (lps)	17.6 (1.1)	13.7 (0.9)	31.5 (2.0)	25.2 (1.6)
	Unit Pressure Drop, ft of Water (kPa)	15 (44.9)	9.8 (29.3)	30 (89.7)	20 (59.8)
85°F DB, 64.4°F WB, 52°F DP, 32% RH (29.4°C DB, 18°C WB)	Total, kW (BTUH)	21.7 (74,000)	19.9 (67,900)	39.3 (134,100)	37.2 (126,900)
	Sensible, kW (BTUH)	20.7 (70,600)	19.7 (67,200)	36.3 (123,900)	35.2 (120,100)
	Flow Rate, GPM (lps)	15.3 (1.0)	11.7 (0.7)	27.9 (1.8)	22.1 (1.4)
	Unit Pressure Drop, ft of Water (kPa)	12 (35.9)	7.5 (22.4)	24 (71.8)	16 (47.8)

**Table 2.14 Performance Data —Chilled Water CR032RC and CR040RC (continued)**

Model Size		CR032RC	CR040RC
		50°F (10°C) EWT-62°F (16.7°C) LWT <sup>1</sup>	
105°F DB, 70.7°F WB, 52°F DP, 17% RH (40.6°C DB, 21.5°C WB)	Total, kW (BTUH)	29.6 (101,000)	50.7 (173,000)
	Sensible, kW (BTUH)	29.6 (101,000)	50.7 (173,000)
	Flow Rate, GPM (lps)	17.2 (1.1)	29.7 (1.9)
	Unit Pressure Drop, ft of Water (kPa)	14 (41.9)	27 (80.7)
100°F DB, 69.2°F WB, 52°F DP, 20% RH (37.8°C DB, 20.7°C WB)	Total, kW (BTUH)	26.3 (89,700)	45.7 (155,900)
	Sensible, kW (BTUH)	26.3 (89,700)	45.7 (155,900)
	Flow Rate, GPM (lps)	15.4 (1.0)	27.0 (1.7)
	Unit Pressure Drop, ft of Water (kPa)	12 (35.9)	23 (68.8)
95°F DB1, 67.7°F WB, 52°F DP, 23% RH (35°C DB, 19.8°C WB)	Total, kW (BTUH)	23.1 (78,800)	40.7 (138,900)
	Sensible, kW (BTUH)	23.1 (78,800)	40.7 (138,900)
	Flow Rate, GPM (lps)	13.6 (0.9)	24.1 (1.5)
	Unit Pressure Drop, ft of Water (kPa)	9.5 (28.4)	19 (56.8)
90°F DB, 66.1°F WB, 52°F DP, 27% RH (32.2°C DB, 18.9°C WB)	Total, kW (BTUH)	19.9 (67,900)	35.7 (121,800)
	Sensible, kW (BTUH)	19.9 (67,900)	35.7 (121,800)
	Flow Rate, GPM (lps)	11.7 (0.7)	21.3 (1.3)
	Unit Pressure Drop, ft of Water (kPa)	7.3 (21.8)	15 (44.9)
85°F DB, 64.4°F WB, 52°F DP, 32% RH (29.4°C DB, 18°C WB)	Total, kW (BTUH)	16.5 (56,300)	30.5 (104,100)
	Sensible, kW (BTUH)	16.5 (56,300)	30.5 (104,100)
	Flow Rate, GPM (lps)	9.8 (0.6)	18.3 (1.2)
	Unit Pressure Drop, ft of Water (kPa)	5.4 (16.1)	11 (32.9)
Fan Section			
Return Air Volume, ACFM (ACMH)		2,500 (4,247)	3,620 (6,150)

**Table 2.14 Performance Data —Chilled Water CR032RC and CR040RC (continued)**

Model Size	CR032RC	CR040RC
Standard Fan Motor, hp (kw)	1.3 (0.98)	2.14 (1.60)
Number of Fans	6	2
External Static Pressure, in.w.g. (Pa)	0 <sup>1</sup>	0 <sup>1</sup>
<ol style="list-style-type: none"> <li>1. Certified in accordance with the AHRI Datacom Cooling Certification Program at AHRI Standard 1360 (I-P) Standard Rating Conditions. Certified units may be found in the AHRI Directory at <a href="http://www.ahridirectory.org">www.ahridirectory.org</a>.</li> <li>2. Some options or combinations of options may result in reduced air flow. Consult factory for recommendations.</li> <li>3. Data rated at 100% fan speed and with Standard Feature filter (MERV1 for 300mm and MERV8 for 600mm).</li> <li>4. Net capacity data has fan motor heat factored in for all ratings.</li> <li>5. Consult factory for alternate performance outputs. Performance data generated in LRS Update Version 12/13/2019.</li> </ol>		

**Table 2.15 Physical Data—Chilled Water, 600 mm (24 in.)**

Parameter	40-kW Models
<b>Evaporator Coil</b>	
Face Area, ft <sup>2</sup> (m <sup>2</sup> )	7.26 (0.674)
Rows	6
Face Velocity, FPM (m/s)	499.0 (2.54)
<b>Electric Reheat Single Stage</b>	
Capacity, BTU/H (kW)	460 V: 20,472 (6.0) 208 V: 16,719 (4.9)
<b>Steam Generating Humidifier</b>	
Capacity, lb/hr (kg/hr)	5.0 (2.3)
Capacity, kW	1.79
<b>Filter Section - Disposable Type</b>	
	<b>MERV 8 - Standard Pleated Filter</b>
Quantity	2
Nominal Size, in. (mm)	31-1/2 x 17-1/2 x 4 (800 x 445 x 100)
Effective Surface Area - ft <sup>2</sup> (m <sup>2</sup> )	16.4 (1.52)
	<b>MERV 11 - Optional Pleated Filter</b>
Quantity	2
Nominal Size, in. (mm)	31-1/2 x 17-1/2 x 4 (800 x 445 x 100)
Effective Surface Area - ft <sup>2</sup> (m <sup>2</sup> )	16.4 (1.52)
<b>Motorized Ball Valve</b>	
Maximum Allowable Pressure, psi (kPa)	325 (2241)
Maximum Close-Off Pressure, psi (kPa)	200 (1379)
Maximum Differential Pressure (Full Flow), psi (kPa)	50 (345)

**Table 2.16 Physical Data—Chilled Water, 300mm (12 in.)**

Parameter	CR032RC1
<b>Fan Data</b>	
Total Airflow, CFM(m3/h)	2550 (4332)
Total Fan Motor hp (kW)	1.3 (0.98)
Number of Fans	6
<b>Evaporator</b>	
Face Area, ft2 (m2)	7.75 (0.72)
Rows	3
Face Velocity	329 (1.67)
<b>Filter Section</b>	
	<b>Washable MERV1</b>
Quantity	2
Nominal Size, in. (mm)	36 X 10 X0.4 (914 X 254 X 10)
Effective Surface Area, ft <sup>2</sup> (m <sup>2</sup> )	2.4 (0.22)
	<b>2" MERV8</b>
Quantity	2
Nominal Size, in. (mm)	36 X 10 X2 (914 X 254 X 51)
Effective Surface Area, ft <sup>2</sup> (m <sup>2</sup> )	5.8 (0.54)
<b>Motorized Ball Valve</b>	
Maximum Allowable Pressure, PSI (kPa)	325 (2241)
Maximum Close-off Pressure, PSI (kPa)	200 (1379)
Maximum Differential Pressure (Full Flow), PSI (kPa)	50 (345)

### 2.4.1 Operating Limits for Chilled Water Systems

**Table 2.17 Operating Limits—Chilled Water Systems**

Models	Maximum Water Pressure, psi (kPa)	Maximum Close-Off Pressure, psi (kPa)	Minimum Entering Water Temperature, °F (°C)
			Design Condition
CR032RC CR040RC	325 (2241)	200 (1379)	40 (4.4)

### 2.4.2 Sound Data for Chilled Water Systems

Table 2.18 below, and Table 2.19 on the next page, show the sound pressure level in free field at 5 feet (1.5 m) high and 6-1/2 feet (2 m) in front of the air conditioner with fan in operation.

Sound power is an absolute measurement that can be used for comparisons. Sound pressure values can be used for comparisons only when all sound measurement parameters match exactly.

**Table 2.18 Sound Data—CR040RC**

Model Type		Chilled Water CR040RC, 600 mm (24 in.) with 2 Fans with Filter			
Factory Fan Speed %		100	75	50	
Sound Power Level (PWL)	Airflow	SCFM	2880	2145	1415
		m3/h	4893	3644	2404
	Octave Band Frequency (Hz)	31.5 dB	86.4	80.8	75.1
		63 dB	78.1	72.5	66.8
		125 dB	82.4	76.8	71.1
		250 dB	84.6	79	73.3
		500 dB	79.2	73.6	67.9
		1000 dB	75	69.4	63.7
		2000 dB	76.4	70.8	65.1
		4000 dB	70.9	65.3	59.6
		8000 dB	63.8	58.2	52.5
		Sound Pressure Level (SPL)	A-Scale Weighted, dB (A)		82.8
At Suction side, 2 m distance, free field conditions (2 m, f.f., dBA)			71.6	66.0	60.3

**Table 2.19 Sound Data—CR032RC**

Model Type		Chilled Water CR032RC, 300 mm (12 in.) with 6 Fans with Filter			
		Fan Speed %	100	75	50
Sound Power Level (PWL)	Airflow	SCFM	3100.0	2500.0	1650.0
		m3/h	5268.0	4248.0	2804.0
	Octave Band Frequency (Hz)	315 dB	—	—	—
		63 dB	—	—	—
		125 dB	73.0	70.5	71.9
		250 dB	83.1	79.8	66.8
		500 dB	82.2	79.9	68.0
		1000 dB	82.0	78.2	65.8
		2000 dB	78.9	74.7	60.3
		4000 dB	71.0	66.7	56.0
8000 dB	65.5	63.1	52.6		
	A-Scale Weighted, dB (A)	86.2	82.4	70.2	
Sound Pressure Level (SPL)		Inlet, dB(A)	77.5	73.5	62.8
		Outlet, dB(A)	83.4	80.7	71.0
		At Suction Side, 2 m distance, 1.5 m above ground, free field conditions (2m, f.f, dBA)	66.5	62.5	51.8
		At Discharge side, 2 m distance, 1.5 m above ground, free field conditions (2 m, f.f, dBA)	72.4	69.7	60.0



## 3 Electrical Power Requirements

### NOTICE

Risk of exceeding line-to-ground limit. Can cause equipment damage.

The electrically commutated (EC) motors included in 480-V CR035 and CR040 units are suitable for connection to power supplies with 300 V or less line to ground potential. Excess line-to-ground voltage can cause capacitor failure internal to the motors.

Power supplies such as 480-V wye with solidly grounded neutral have 277 V line to ground and are acceptable.

Power supplies such as 480-V wye with high resistance (or impedance) ground, 480-V delta without ground or with floating ground, 480-V delta with corner ground or 480-V delta with grounded center tap will exceed the 300 V line-to-ground limit.

### 3.1 Air Cooled Systems Electrical Data

**Table 3.1 Electrical Data—Air Cooled, 600 mm (24 in.) with Condensate Pump**

Voltage	CR020RA		CR035RA	
	208/3/60	460/3/60	208/3/60	460/3/60
Reheat, with or without Humidifier				
FLA	50.8	24.2	62.0	32.2
WSA	61.4	29.2	75.4	39.1
OPD	80	35	100	50
No Reheat, with Humidifier				
FLA	42.6	20.4	53.8	28.4
WSA	49.1	23.5	63.1	33.4
OPD	70	35	100	50
No Reheat, No Humidifier				
FLA	34.2	16.7	45.4	24.7
WSA	40.7	19.8	54.7	29.7
OPD	60	30	90	45
FLA = Full Load Amps; WSA = Wire Size Amps; OPD = Maximum Overcurrent Protection Device				

**Table 3.2 Electrical Data—Air Cooled CR019, 300 mm (12 in.) with Condensate Pump**

Voltage	208-230 V/3Ph/60 Hz	460 V/3Ph/60 Hz (Wye Connected)
No Reheat, No Humidifier		
FLA	33.4	16.8
WSA	39.9	20
OPD	60	30
FLA = Full Load Amps; WSA = Wire Size Amps; OPD = Maximum Overcurrent Protection Device		

## 3.2 Water/Glycol Systems Electrical Data

**Table 3.3 Electrical Data—Water/Glycol, 600 mm (24 in.) with Condensate Pump**

Voltage	CR020RW		CR035RW	
	208/3/60	460/3/60	208/3/60	460/3/60
Reheat, with or without Humidifier				
FLA	50.8	24.2	62.0	32.2
WSA	61.4	29.2	75.4	39.1
OPD	80	35	100	50
No Reheat, with Humidifier				
FLA	42.6	20.4	53.8	28.4
WSA	49.1	23.5	63.1	33.4
OPD	70	35	100	50
No Reheat, No Humidifier				
FLA	34.2	16.7	45.4	24.7
WSA	40.7	19.8	54.7	29.7
OPD	60	30	90	45
FLA = Full Load Amps; WSA = Wire Size Amps; OPD = Maximum Overcurrent Protection Device				

**Table 3.4 Electrical Data—Water/Glycol CR019, 300 mm (12 in.) with Condensate Pump**

Voltage	208-230 V/3Ph/60 Hz	460 V/3Ph/60 Hz (Wye Connected)
No Reheat, No Humidifier		
FLA	33.4	16.8
WSA	39.9	20
OPD	60	30
FLA = Full Load Amps; WSA = Wire Size Amps; OPD = Maximum Overcurrent Protection Device		

### 3.3 Chilled Water Systems Electrical Data

Table 3.5 Electrical Data—Chilled Water, 600 mm (24 in.) with Condensate Pump

Voltage	CR040RC	
	208/3/60	460/3/60
Reheat, with or without Humidifier		
FLA	24.9	12.2
WSA	31.1	15.3
OPD	35	20
No Reheat, with Humidifier		
FLA	16.7	8.4
WSA	20.9	10.5
OPD	25	15
No Reheat, No Humidifier		
FLA	8.3	4.7
WSA	9.1	5.1
OPD	15	15

FLA = Full Load Amps; WSA = Wire Size Amps; OPD = Maximum Overcurrent Protection Device

Table 3.6 Electrical Data—Chilled Water, 300 mm (12 in.) with Condensate Pump

Voltage	CR032RC			
	120 V/1Ph/60 Hz	208-230 V/1Ph/60 Hz	208-230 V/3Ph/60 Hz	460 V/3Ph/60 Hz (Wye Connected)
No Reheat, No Humidifier				
FLA	14.6	12.3	7.5	4.3
WSA	15.2	12.8	8.3	4.8
OPD	20	15	15	15

FLA = Full Load Amps; WSA = Wire Size Amps; OPD = Maximum Overcurrent Protection Device

### 3.4 Electrical Field Connections

Electrical service must conform to national and local electrical codes.

The electrical connections are described in the submittal documents included in the [Submittal Drawings](#) on page 67.

The following table lists the relevant documents by number and title.

**Table 3.7 Electrical Field Connection Drawings**

Document Number	Title
<b>600-mm (24-in.) Models</b>	
DPN001884	Electrical Field Connections Descriptions, 600 mm (24 in.) Models
DPN002841	CANbus & Interlock Connections between 600 mm (24 in.) Unit & Vertiv™ Liebert® MC Condenser
DPN001911	Vertiv™ Liebert® IntelliSlot™ Cable Connection Paths, 600mm (24 inch) Models
DPN003592	Vertiv™ Liebert® iCOM™ Unit-to-unit Network Connections, 600 mm (24 in.) Models
<b>300-mm (12-in.) Models</b>	
DPN002810	Electrical Field Connections Descriptions, 300 mm (12 in.) Models
DPN003036	CANbus & Interlock Connections between 300 mm (12 in.) Unit & Liebert® MC Condenser
DPN003588	Low Voltage Field Wiring Routing, 300 mm (12 in.) All Models
DPN003589	Power Cable Routing Bottom Entry, 300 mm (12 in.) Air Cooled & Water Glycol Cooled Models
DPN003590	Power Cable Routing Bottom Entry 300 mm (12 in.) Chilled Water Models
DPN002814	Liebert® IntelliSlot™ Cable Connection Paths, 300mm (12 inch) Models
DPN003593	Liebert® iCOM™ Unit-to-unit Network Connections, 300 mm (12 in.) Models

## 4 Dimensions and Weights

### 4.1 Unit Weights

Table 4.1 Shipping Weights

Model No.	Unit (Dry) lb (kg)			Domestic Packaging, lb (kg)			Export Packaging, lb (kg)		
	Air	Water/Glycol	Chilled Water	Air	Water/Glycol	Chilled Water	Air	Water/Glycol	Chilled Water
CR019	507 (230)	545 (247)	—	649 (294)	687 (311)	—	721 (327)	782 (355)	—
CR032	—	—	418 (190)	—	—	560 (254.0)	—	—	683 (309.8)
CR020	739 (235)	772 (350)	—	846 (384)	879 (399)	—	953 (432)	986 (447)	—
CR035	805 (365)	849 (385)	—	912 (414)	956 (434)	—	1019 (462)	1063 (482)	—
CR040	—	—	728 (330)	—	—	835 (379)	—	—	942 (427)

### 4.2 Planning Dimensions

The unit, floor stand, and plenum dimensions are described in the submittal documents included in the [Submittal Drawings](#) on page 67.

The following table lists the relevant documents by number and title.

Table 4.2 Dimension Planning Drawings

Document Number	Title
DPN001791	Cabinet and Floor Planning Dimensional Data, 600 mm (24 in.)
DPN002807	Cabinet and Floor Planning Dimensional Data, 300 mm (12 in.)

This page intentionally left blank

## 5 Piping Connections

Field installed piping must be installed in accordance with local codes.

The pipe connection locations, piping general arrangement, and schematics are described in the submittal documents included in the [Submittal Drawings](#) on page 67.

The following tables list the relevant documents by number and title.

**Table 5.1 Piping General Arrangement Drawings**

Document Number	Title
<b>Air Cooled Systems</b>	
DPN002858	Piping Arrangement, 600 mm (24 in.) Air Cooled w/ Liebert® MC Condenser Models
DPN002808	Liebert® Piping Arrangement, 300 mm (12 in.) Air Cooled w/ Liebert® MC Condenser Models
<b>Water/Glycol Cooled Systems</b>	
DPN001985	Piping Arrangement, 600 mm Water/Glycol Cooled Models
DPN003039	Piping Arrangement, 300 mm (12 in.) Water/Glycol Cooled Models
<b>Chilled Water Systems</b>	
DPN001986	Piping Arrangement, 600 mm (24 in.) Chilled Water Models
DPN002976	Piping Arrangement, 300 mm (12 in.) Chilled Water Models

**Table 5.2 Piping Connection Drawings**

Document Number	Title
<b>Air Cooled Systems</b>	
DPN001792	Connection Locations, CR020R & CR035R Air Cooled Models
DPN002813	Connection Locations, 300-mm (12-in.) Air Cooled Models
<b>Water/Glycol Cooled Systems</b>	
DPN001793	Connection Locations, CR020R & CR035R Water/Glycol Models
DPN003040	Connection Locations, 300 mm (12 in.) Water/Glycol Cooled Models
<b>Chilled-water Systems</b>	
DPN001794	Connection Locations, CR040R Chilled Water Models
DPN002815	Connection Locations, 300 mm (12 in.) Chilled Water Models

## 5.1 Refrigerant Line Sizes and Equivalent Lengths

**Table 5.3 Vertiv™ Liebert® CRV Recommended Refrigerant Line Sizes, O.D. CU for Vertiv™ Liebert® MC Condenser**

Liebert® CRV Model Number	Total Equivalent Length, ft. (m)	Hot-gas Line, in. (mm)	Liquid Line, in. (mm)
CR019RA/CR020RA	50 (15)	3/4 (19.1)	5/8 (15.9)
	100 (30)	3/4 (19.1)	5/8 (15.9)
	150 (45)	3/4 (19.1)	5/8 (15.9)
	300 (91)	7/8 (22.2)*	3/4 (19.1)
CR035RA	50 (15)	7/8 (22.2)	3/4 (19.1)
	100 (30)	7/8 (22.2)	3/4 (19.1)
	150 (45)	7/8 (22.2)	3/4 (19.1)
	300 (91)	1-1/8 (28.6)*	7/8 (22.2)

Contact your Vertiv representative for line sizing for runs longer than 300 ft. (91.4 m) equivalent length.

\*Must down size vertical riser one trade size (1-1/8" to 7/8", 7/8" to 3/4", 3/4" to 5/8", 5/8" to 1/2").

Source: DPN000788, Rev. 13

**Table 5.4 Liebert® MC Connection Sizes**

Model No.	Number of Fans	Connection Sizes, OD, in. (mm)	
		Hot Gas Line	Liquid Line
MCS028	1	7/8	5/8
MCM040	1	7/8	5/8
MCM080	2	1-1/8	7/8
MCL055	1	1-1/8	7/8
MCL 110	2	1-3/8	1-1/8

**Table 5.5 Liebert® MC Piping Connection Sizes with Liebert® Lee-Temp**

Model #	Condenser Connections, OD, In.		Liebert® Lee-Temp Connections		
	Hot Gas	Liquid	Hot Gas Tee IDS In.	Liquid Line to Lee-Temp Valve, ODS, In.	Receiver Out, IDS In.
MCS028	7/8	5/8	7/8	5/8	5/8
MCM040	7/8	5/8	7/8	5/8	5/8
MCM080	1-1/8	7/8	1-1/8	7/8	1-1/8
MCL055	1-1/8	7/8	1-1/8	7/8	7/8
MCL110	1-3/8	1-1/8	1-3/8	1-1/8	1-1/8

Source: DPN002167, Rev. 7



## 6 Heat Rejection—Vertiv™ Liebert® MC Condensers

### 6.1 Vertiv™ Liebert® MC Match-up Selections

Table 6.1 Standard Sound Mode, 95°F (35°C)/23% RH Return Air Conditions

Indoor Model	Unit Width	Outdoor Design Ambient Temperature, °F (°C)					
		95 (35)	100 (38)	105 (41)	110 (43)	115 (46)	120 (49)
CR019RA	300 mm (12 in.)	MCS028E1	MCM040E1	MCM040E1	MCM040E1	MCL055E1	MCL055E1
CR020RA	600 mm (24 in.)	MCS028E1	MCM040E1	MCM040E1	MCM040E1	MCL055E1	MCL055E1
CR035RA	600 mm (24 in.)	MCM040E1	MCL055E1	MCL055E1	MCM080E1	MCM080E1	MCM080E1

Table 6.2 Low Noise Mode, 95°F (35°C)/23% RH Return Air Conditions

Indoor Model	Unit Width	Outdoor Design Ambient Temperature, °F (°C)					
		95 (35)	100 (38)	105 (41)	110 (43)	115 (46)	120 (49)
CR019RA	300 mm (12 in.)	MCS028E1	MCM040E1	MCL055E1	MCL055E1	MCM080E1	—
CR020RA	600 mm (24 in.)	MCS028E1	MCM040E1	MCL055E1	MCL055E1	MCM080E1	—
CR035RA	600 mm (24 in.)	MCL055E1	MCL055E1	MCM080E1	MCM080E1	MCL110E1	—

**NOTE:** Match-ups for Low Noise Mode are based on Liebert® MC Condenser fan set at 80% maximum fan speed. Low Noise Mode is controlled by the Liebert® CRV iCOM™ control and must be linked to the Liebert® MC by the standard CANbus communication wires, field-supplied. Liebert® Lee-Temp receiver must be added to the Liebert® MC for proper head pressure control. Contact the factory for match-ups if sound requirements are more stringent than 80% fan speed will yield.

## 6.2 Electrical Power Requirements

**Table 6.3** below lists the power requirements by model number. **Table 6.4** on the facing page lists the additional electrical requirements if your system includes a Liebert® Lee-Temp Receiver.

**Table 6.3 Electrical Data, Three-Phase, 60 Hz Condenser, Premium EC Fan Control**

Model	Voltage	FLA	WSA	OPD
<b>Small Platform</b>				
MCS028	208/230V	3.0	3.8	15
	380V	1.4	1.8	15
	460V	1.4	1.8	15
	575V	1.2	1.5	15
<b>Medium Platform</b>				
MCM040	208/230V	2.3	2.9	15
	380V	1.4	1.8	15
	460V	1.4	1.8	15
	575V	1.2	1.5	15
MCM080	208/230V	4.6	5.2	15
	380V	2.8	3.2	15
	460V	2.8	3.2	15
	575V	2.4	2.7	15
<b>Large Platform</b>				
MCL055	208/230V	5.7	7.1	15
	380V	2.8	3.5	15
	460V	2.8	3.5	15
	575V	2.3	2.9	15
MCL110	208/230V	11.4	12.8	15
	380V	5.6	6.3	15
	460V	5.6	6.3	15
	575V	4.7	5.3	15
1. FLA = Full Load Amps; WSA = Wire Size Amps; OPD = Maximum Overcurrent Protection Device.				
Source: DPN005027 Rev. 0				

**Table 6.4 Electrical Data, Liebert® Lee-Temp Receiver, 60 Hz**

Rated Voltage - Single-Phase:	120	208/230
Watts/Receiver	150	150
Amps	1.4	0.7
Wire Size Amps	1.8	0.9
Maximum Overcurrent Protection Device, Amps	15	15
<ol style="list-style-type: none"> <li>1. The Liebert® Lee-Temp receiver requires a separate power feed for heaters.</li> <li>2. The condenser is not designed to supply power to the receiver heater pads.</li> <li>3. The Liebert Lee-Temp system allows system start up and positive head pressure control in outdoor temperature as low as -30°F (-34°C).</li> </ol>		

## 6.2.1 Condenser and Options Net Weights

Total unit weight is the sum of the condenser weight with the selected legs plus the weight of any option.

**Table 6.5 Condenser and Options Net Weights—Small Condensers**

Condenser Model		MCS028
Refrigeration Circuits		1
Condenser Dry Weight, lb (kg)	18" Leg	154 (70)
	36" Leg	286 (130)
	48" Leg	318 (144)
	60" Leg	349 (158)
Additional Weight for Options, lb (kg)		
Liebert® Lee-Temp Receiver		55 (25)
575V T Transformer		55 (25)
Coated Coil		4 (2)
Seismic/Wind Bracing, 18-in. legs		40 (18)
Condenser + Liebert Lee-Temp + Coated Coil + 575 V Transformer + Seismic/Wind Bracing = Total Weight		
Source: DPN003034, Rev. 6		

**Table 6.6 Condenser and Options Net Weights—Medium Condensers**

Condenser Model		MCM040	MCM080
Refrigeration Circuits		1	1
Condenser Dry Weight, lb (kg)	18" Leg	231 (105)	441 (200)
	36" Leg	363 (165)	590 (268)
	48" Leg	395 (179)	622 (282)
	60" Leg	426 (193)	653 (296)
Additional Weight for Options, lb (kg)			
Liebert® Lee-Temp Receiver		55 (25)	100 (45)
575V Transformer		60 (27)	70 (32)
Coated Coil		5 (2)	10 (5)
Seismic/Wind Bracing, 18-in. legs		40 (18)	40 (18)
Condenser + Liebert Lee-Temp or+ Coated Coil + 575V Transformer + Seismic/Wind Bracing = Total Weight			
Source: DPN003034, Rev. 6			

**Table 6.7 Condenser and Options Net Weights—Large Condensers**

Condenser Model		MCL055	MCL110
Refrigeration Circuits		1	1
Condenser Dry Weight, lb (kg)	18" Leg	344 (156)	602 (273)
	36" Leg	486 (220)	766 (347)
	48" Leg	518 (235)	798 (362)
	60" Leg	549 (249)	829 (376)
Additional Weight for Options, lb (kg)			
Liebert® Lee-Temp Receiver		60 (27)	115 (52)
575V Transformer		67 (30)	77 (35)
Coated Coil		8 (4)	16 (7)
Seismic/Wind Bracing, 18-in. legs		40 (18)	40 (18)
Condenser + Liebert Lee-Temp or+ Coated Coil + 575 V Transformer + Seismic/Wind Bracing = Total Weight			
Source: DPN003034, Rev. 6			

## 6.3 Vertiv™ Liebert® MC Planning Dimensions

The condenser dimensions are described in the submittal documents included in the [Submittal Drawings](#). Condensers mounted above and below the relative elevation of the indoor unit must follow the guidelines found in the submittal drawings listed in the table.

The following table lists the relevant documents by number and title.

**Table 6.8 Dimension Planning Drawings**

Document Number	Title
DPN003436	Condenser Dimensional Data, MCS028, MCM040, MCL055
DPN003437	Condenser Dimensional Data, MCS056, MCM080, MCL110, Dual Circuit
DPN003954	Liebert® MC Condenser Positioning Above/Same Level/Below Indoor Unit

## 6.4 Vertiv™ Liebert® MC Piping

Field installed piping must be installed in accordance with local codes.

The pipe connection locations are described in the submittal documents included in the [Submittal Drawings](#) on page 67.

The following table lists the relevant documents by number and title.

**Table 6.9 Piping Connection Drawings**

Document Number	Title
DPN002166	Single Circuit Piping without Liebert® Lee-Temp
DPN002167	Single Circuit Piping with Liebert® Lee-Temp

## 6.5 Vertiv™ Liebert® MC Electrical Field Connections

Condenser rated voltage should be verified with available power supply before installation. Refer to the unit’s electrical schematic and serial tag for specific electrical requirements. Line voltage electrical service is required for all condensers at the location of the condenser. The voltage supply to the condenser may not be the same voltage supply as required by the indoor unit. Consider using UPS equipment on both data center cooling units and Liebert® MC to maintain uninterrupted cooling capability. Refer to the unit’s serial tag for specific condenser electrical requirements. A unit disconnect is standard. However, a site disconnect may be required per local code to isolate the unit for maintenance. Route the supply power to the site disconnect switch and then to the unit. Route the conduit to the knockout provided in the bottom right end of the electrical control enclosure. Connect the earth ground wire lead to the marked earth ground connection terminal provided near the factory installed disconnect switch.

**NOTE: Liebert® Lee-Temp kits require a separate line voltage electrical supply for the heated receivers.**

See **Table 3.1** on page 21, to **3.3** on page 23, for power requirements.

The electrical connections are described in the submittal documents included in the [Submittal Drawings](#) on page 67.

The following table lists the relevant documents by number and title.

**Table 6.10 Electrical Field Connection Drawings**

Document Number	Title
<b>Power Supply Wiring</b>	
DPN002169	Electrical Field Connections, without Liebert® Lee-Temp
DPN002374	Electrical Field Connections, with Liebert® Lee-Temp
<b>Low-voltage wiring</b>	
DPN002841	CANbus communication connection between Liebert® CRV 600 mm (24 in.) and Liebert® MC Condenser
DPN003036	CANbus communication connection between Liebert® CRV 300 mm (12 in.) and Liebert® MC Condenser

# 7 Heat Rejection—Vertiv™ Liebert® Drycoolers and Pumps

## 7.1 Liebert® Drycooler Match-up Selections

Vertiv™ Liebert® Drycoolers provide glycol to the internal, high efficiency, brazed plate condenser of the Liebert® CRV to maintain proper condensing temperatures. Ethylene or Propylene glycol must be added to the water loop to prevent freezing during low outdoor temperatures. **Figure 7.1** on the next page shows the percentage of ethylene glycol that should be added based on the minimum outdoor temperature. If the Liebert® CRV is attached to an open water loop (cooling tower, city water, etc.) a field supplied 16-20 mesh strainer must be installed (not supplied by Vertiv™) within 10 feet (30 m) upstream of the unit to prevent debris from entering the unit.

**Table 7.1 Glycol Cooled Liebert® Drycooler Match-up Selections**

Model	Outdoor Temperature, °F (°C)	No. of Fans	Models <sup>1</sup>	Suggested Pump Horsepower <sup>2</sup>
19 kW and 20 kW	95 (35)	1	DSF112_8	S1.5*
	100 (38)	2	DSO174_8	S1.5*
	105 (41)	2	DSO225_16	S2*
35 kW	95 (35)	2	DSO197	S2*
	100 (38)	3	DSO310_16	S2*
	105 (41)	4	DSO419_16	S3*

\* = A (460 V/ 3 f/ 60 Hz) -or- Y (208/230 V/ 3 ph/ 60 Hz) -or- B (575 V/ 3 ph/ 60 Hz)

- Match-ups sized for 40% propylene glycol, one Liebert® CRV, one pump and one drycooler systems. Fuses and overloads not included with drycoolers. Liebert® pump packages are shipped with needed drycooler fuses and overloads or they will need to be field supplied for field supplied pumps.
- Suggested pump selections provide at least 30-ft H2O head for piping losses.

**NOTE: Drycooler recommendations based on one drycooler per indoor unit, 40% propylene glycol, 75°F/45% RH unit return air conditions. Consult factory for match-up needs using multiple indoor units, different return air conditions or alternate glycol temperatures.**

Figure 7.1 Percentage of Ethylene Glycol Mixed with Water

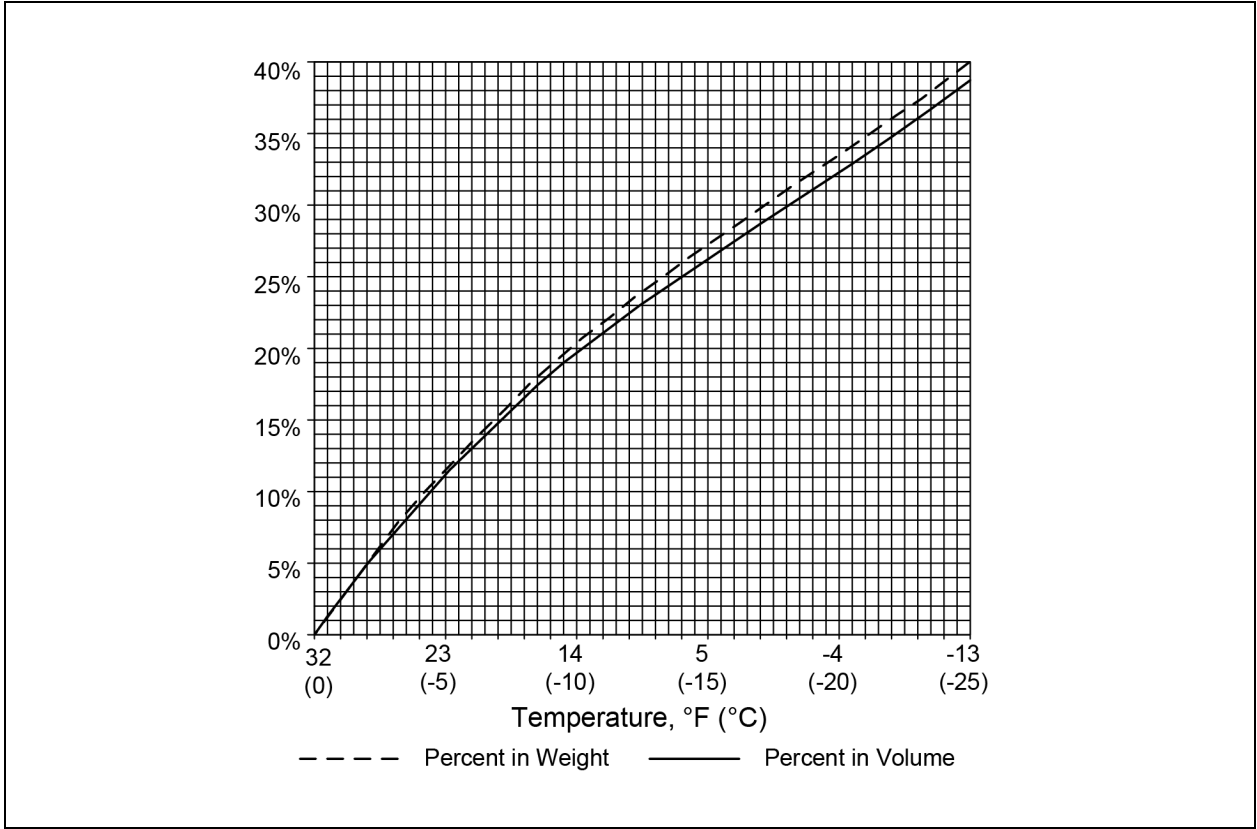

**NOTICE**

Risk of freezing fluid mixture. Can cause equipment damage.

The water supply/loop must be checked periodically for proper glycol mixture content. For safety, calculate the percentage for protection at least 9°F (5°C) below the minimum ambient design temperature.



## 7.2 Vertiv™ Liebert® Drycooler Electrical Power Requirements

Table 7.2 60Hz Electrical Values—Standard Drycoolers with Integral Pump Controls

# of Fans:	1				2				3				4			
Model #:	92, 109, 112				139, 174, 197, 225				260, 310				419			
Pump hp	Ph	FLA	WSA	OPD	Ph	FLA	WSA	OPD	Ph	FLA	WSA	OPD	Ph	FLA	WSA	OPD
<b>208/230/60</b>																
0.75	1	12.4	14.3	20	—	—	—	—	—	—	—	—	—	—	—	—
0.75	3	7	7.9	15	3	10.5	11.4	15	3	14.0	14.9	20	3	17.5	18.4	20
1.5	3	10.1	11.8	15	3	13.6	15.3	20	3	17.1	18.8	25	3	20.6	22.3	25
2.0	3	11.0	12.9	20	3	14.5	16.4	20	3	18.0	19.9	25	3	21.5	23.4	30
3.0	3	14.1	16.8	25	3	17.6	20.3	30	3	21.1	23.8	30	3	24.6	27.3	35
5.0	3	20.2	24.4	40	3	23.7	27.9	40	3	27.2	31.4	45	3	30.7	34.9	50
7.5	3	27.7	33.8	50	3	31.2	37.3	60	3	34.7	40.8	60	3	38.2	44.3	60
<b>460/60</b>																
0.75	3	3.3	3.7	15	3	5.0	5.4	15	3	6.7	7.1	15	3	8.4	8.8	15
1.5	3	4.7	5.5	15	3	6.4	7.2	15	3	8.1	8.9	15	3	9.8	10.6	15
2.0	3	5.1	6.0	15	3	6.8	7.7	15	3	8.5	9.4	15	3	10.2	11.1	15
3.0	3	6.5	7.7	15	3	8.2	9.4	15	3	9.9	11.1	15	3	11.6	12.8	15
5.0	3	9.3	11.2	15	3	11.0	12.9	20	3	12.7	14.6	20	3	14.4	16.3	20
7.5	3	12.7	15.5	25	3	14.4	17.2	25	3	16.1	18.9	25	3	17.8	20.6	30

## 7.3 Vertiv™ Liebert® Drycooler Planning Dimensions

The unit dimensions are described in the submittal documents included in the [Submittal Drawings](#) on page 67.

The following table lists the relevant documents by number and title.

Table 7.3 Dimension Planning Drawings

Document Number	Title
DPN000274	Cabinet and Anchor Dimensions for 1 to 4 Fan Drycoolers

## 7.4 Vertiv™ Liebert® Drycooler Piping Guidelines

Field installed piping must be installed in accordance with local codes.

The pipe connection locations are described in the submittal documents included in the [Submittal Drawings](#) on page 67 .

The following table lists the relevant documents by number and title.

**Table 7.4 Piping Connection Drawings**

Document Number	Title
DPN000275	Connection Locations for Standard 1 Fan, 2 Fan, 3 Fan, and 4 Fan Units
DPN003822	Typical Arrangement for Multiple Drycoolers and Multiple Indoor Thermal Management Units

## 7.5 Vertiv™ Liebert® Drycooler Electrical Field Connections

Electrical service must conform to national and local electrical codes.

The electrical connections are described in the submittal documents included in the [Submittal Drawings](#) on page 67 .

The following tables list the relevant documents by number and title.

**Table 7.5 Electrical Field Connection Drawings**

Document Number	Title
DPN000276	Electrical Field Connections for Fluid Temperature Control

## 7.6 Vertiv™ Liebert® Drycooler Pump Packages

The planning dimensions, electrical power supply requirements, piping connections, and electrical connections are described in the submittal documents included in the [Submittal Drawings](#) on page 67 .

The following table lists the relevant documents by number and title.

**Table 7.6 Liebert® Drycooler Pump Drawings**

Document Number	Title
DPN000329	Pump Electrical Power Data and Piping Connection Sizes
DPN000278	Single Pump Piping Connection Locations and Dimensional Data

Figure 7.2 Pump Curve, 60 Hz

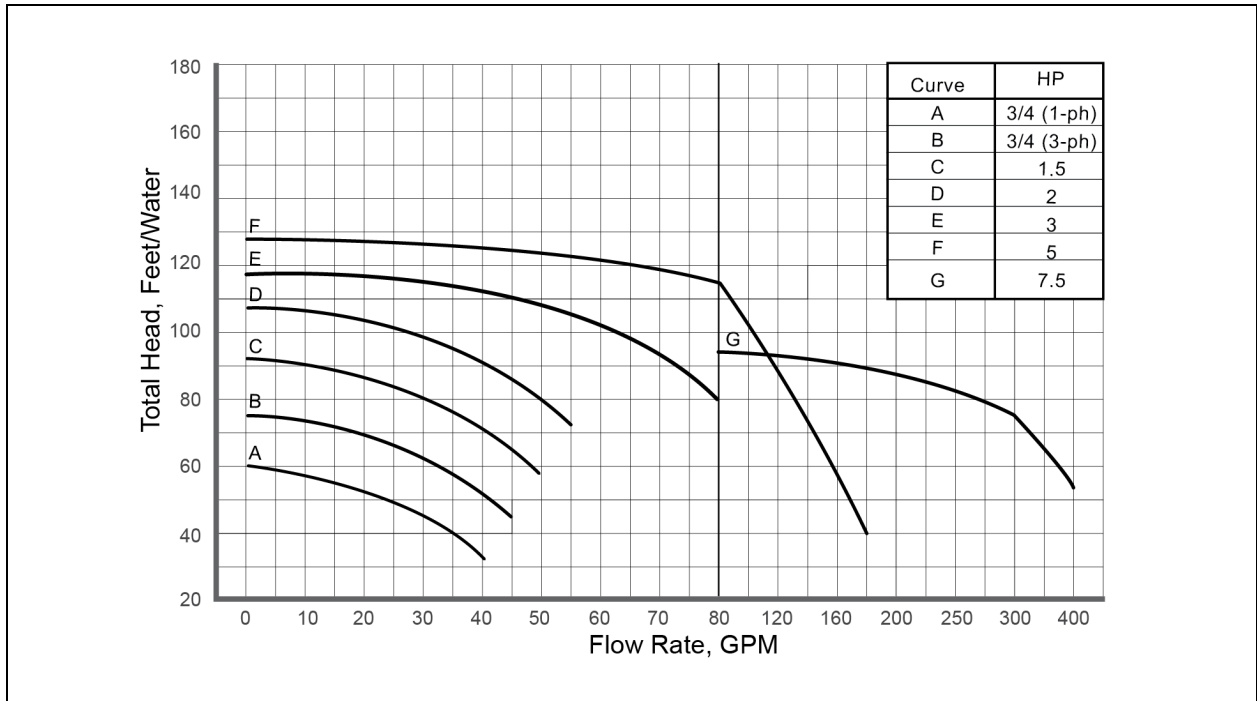

**NOTE:** Higher capacity pumps are available. Please contact your local sales rep for more information.

### 7.6.1 Vertiv™ Liebert® Drycooler Expansion Tank

The expansion tank, included in a standard pump package, has an internal volume of 8.8 gal. (33 l) and a maximum pressure of 100 psi (690 kPa).

The tank is sized for a typical open system with a fluid volume of less than 75 gal. (280 l). When used in a closed system, volumes of up to 140 gal. (530 l) can be accommodated. We recommend use of a field supplied safety relief valve for systems closed to atmospheric venting. Other piping accessories for filling, venting, or adjusting the fluid in the system, are recommended, but not included.

The planning dimensions and general arrangement are described in the submittal documents included in the [Submittal Drawings](#) on page 67.

The following table lists the relevant documents by number and title.

**Table 7.7 Liebert® Drycooler Pump and Tank Drawings**

Document Number	Title
DPN004183	Expansion Tank General Arrangement and Dimensional Data

## 7.6.2 Compression Tank

The compression tank for glycol/GLYCOOL systems includes:

- Tank
- Airtrol fitting
- Sight glass with shut-off valves
- 50-psi relief valve
- Drain valve

Mounting brackets are not included. Maximum design pressure 125 psig.

The planning dimensions and general arrangement are described in the submittal documents included in the [Submittal Drawings](#) on page 67 .

The following table lists the relevant documents by number and title.

**Table 7.8 Drycooler Pump and Tank Drawings**

Document Number	Title
DPN003898	Compression Tank General Arrangement and Dimensional Data

# Appendices

## Appendix A: Technical Support and Contacts

### A.1 Technical Support/Service in the United States

Vertiv Group Corporation

24x7 dispatch of technicians for all products.

1-800-543-2378

Liebert® Thermal Management Products

1-800-543-2378

Liebert® Channel Products

1-800-222-5877

Liebert® AC and DC Power Products

1-800-543-2378

### A.2 Locations

#### United States

Vertiv Headquarters

1050 Dearborn Drive

Columbus, OH, 43085, USA

#### Europe

Via Leonardo Da Vinci 8 Zona Industriale Tognana

35028 Piove Di Sacco (PD) Italy

#### Asia

7/F, Dah Sing Financial Centre

3108 Gloucester Road

Wanchai, Hong Kong

This page intentionally left blank

## Appendix B: Model Number Nomenclature Detail

**Table B.2** below describes each digit of the 25-digit configuration number. The 14-digit model number consists of the first 10 digits and last four digits of the configuration number.

**Table B.1 Vertiv™ Liebert® CRV 25-digit Configuration Number Example**

Model # Part 1										Model Details											Model # Part 2			
1	2	3	4	5	6	7	8	9	10	11	12	13	14	15	16	17	18	19	20	21	22	23	24	25
C	R	0	3	5	R	A	1	C	7	S	H	1	8	1	1	P	L	U	O	P	A	#	#	#

**Table B.2 Liebert® CRV Model Number Digit Definitions**

Digit	Description
Digits 1 and 2 = Unit Family	CR = Liebert® CRV
Digits 3-5 - Nominal Capacity, kW	019 = DX (300 mm [12 in.] wide) 020 = DX (600 mm [24 in.] wide) 035 = DX (600 mm [24 in.] wide) 032 = CW (300 mm [12 in.] wide) 040 = CW (600 mm [24 in.] wide)
Digit 6 - Row Based, Unit Depth	R = 1100 mm (43.4 in.)
Digit 7 - System Type	A = Air Cooled W = Water/Glycol Cooled C = Chilled Water Cooled
Digit 8 - Fan Type	1 = Variable Speed EC fans
Digit 9 - Power Supply	A = 460V / 3ph / 60Hz (600 mm [24 in.]) C = 208V / 3ph / 60Hz (600 mm [24 in.]) Y = 208-230V / 3ph / 60Hz (300 mm [12 in.]) P = 208-230V / 1ph / 60Hz (300 mm [12 in.]); Control transformer can be tapped to provide 240 V/1ph/60 Hz K = 120V / 1ph / 60Hz (300 mm [12 in.]) 3 = 460V / 3ph / 60Hz-Wye with Neutral required (300 mm [12 in.])
Digit 10 - Cooling System	2 = Two-Way Valve (CW Models Only) 3 = Three-way Valve (CW Models Only) 7 = R-410A Digital Scroll (Air Cooled and 600 mm [24 in.] W/G)

**Table B.2 Liebert® CRV Model Number Digit Definitions (continued)**

Digit	Description
	4 = Top Connections Only (300 mm [12 in.] W/G only) 5 = Bottom Connections Only (300 mm [12 in.] W/G only)
Digit 11 - Humidifier	0 = None S = Steam Generating Canister (600 mm [24 in.] models only)
Digit 12 - Control System	H = Liebert® iCOM™ (9-inch touch color screen display)
Digit 13 - Reheat	0 = None 1 = Electric Reheat (600 mm [24 in.] models only)
Digit 14 - Air Filter	A = 2-in. MERV 8 (300 mm [12 in.] models only) C = 1/2-in. MERV 1 and Clog Filter Switch (300 mm [12 in.] models only) 8 = 4-in. MERV 8 + Clogged Filter Switch (600 mm [24 in.] models only) 9 = 4-in. MERV 11 + Clogged Filter Switch (600 mm [24 in.] models only)
Digit 15 - Water/Glycol Valve Type	1 = Two-Way Valve (W/G only) OR Default Air Cooled Selection 7 = Three-Way Valve (W/G only) H = Default CW Selection
Digit 16 - Enclosure	1 = Standard Color (Z-7021 Black), No Seismic Certification 4 = Standard Color (Z-7021 Black), Seismic Certification Level 2 (Sds = 2.0/2.5)
Digit 17 - High-Voltage Options	5 = Condensate Pump, 5k SCCR, 300 mm (12 in.) 120-V CW Only P = Dual Float Condensate Pump (for units with or without humidifier), 65k SCCR
Digit 18 - Option Package	0 = None C = Reheat and Humidifier Lockout and Additional Alarm Contact (600 mm [24 in.] Only) D = Low Sound Package (600 mm [24 in.] DX Only) L = Low Sound Package and Reheat and Humidifier Lockout and Additional Alarm Contact (600 mm [24 in.] DX Only)
Digit 19 - Liebert® IntelliSlot™ Housing	0 = No Cards U = (1) Liebert® IntelliSlot™ Unity DP™ Card 6 = (1) Liebert® IntelliSlot™ Unity DP Card and (1) Liebert® SiteLink-E Card
Digit 20 - Future Options	0 = None



**Table B.2 Liebert® CRV Model Number Digit Definitions (continued)**

Digit	Description
Digit 21 - Packaging with Ramp P = Domestic S = Export (Seaworthy)	
Digit 22 - Special Features A = No SFAs, Standard Unit (Any Alpha letter except X) X = SFA Included	
Digits 23-25 - Factory Configuration Number	

This page intentionally left blank

## Appendix C: Optional Configuration for Vertiv™ Liebert® CRV Seismic Application

Electrical wiring, conduit, and/or other connections to the equipment is the responsibility of others. Data and recommendations are supplied in the [Submittal Drawings](#) on page 67 , and in the unit installation supplement for seismic installation.

The following table lists the relevant documents by number and title.

**Table C.1 Seismic Application Drawings**

Document Number	Title
DPN002765	Seismic Application for 600 mm (24 in.) Models
DPN003027	Seismic Application for 300 mm (12 in.) Models

This page intentionally left blank

## Appendix D: Optional Configuration for Vertiv™ Liebert® CRV Non-seismic Application

Electrical wiring, conduit, and/or other connections to the equipment is the responsibility of others. Data and recommendations are supplied in the [Submittal Drawings](#) on page 67 , and in the unit installation supplement for non-seismic installation.

The following table lists the relevant documents by number and title.

**Table D.1 Non-seismic Application Drawings**

Document Number	Title
<b>600 mm (24 in.) Models</b>	
DPN003272	Rigid Floor Mount Bracket
DPN003273	Rigid Floor Stand Mounting
<b>300 mm (12 in.) Models</b>	
DPN003694	Rigid Floor Mount Bracket
DPN003696	Rigid Floor Stand Mounting

This page intentionally left blank

## Appendix E: Vertiv™ Liebert® CRV Intended Application

The Liebert® CRV can be applied in virtually any application. Because the unit provides complete temperature and humidity control along with filtration, it can be deployed as the only cooling unit in smaller data centers and network closets. Larger data centers benefit from its standard, rack-sized footprint, deploying it as a supplemental spot cooler to address both hot spots and high density racks. The small footprint and variable cooling and airflow allow the unit to be initially oversized in anticipation of future IT expansion with minimal footprint or energy consumption penalties. The unit can be applied on both raised and non-raised floors, allowing it to work with existing under floor and overhead cooling systems. The unit is compatible with all forms of aisle containment, but the control algorithms have been optimized for cold aisle containment with Liebert® SmartRow™ from Vertiv™.

Figure E.1 Example of High Density Installation with Alternating Cold and Hot Aisles

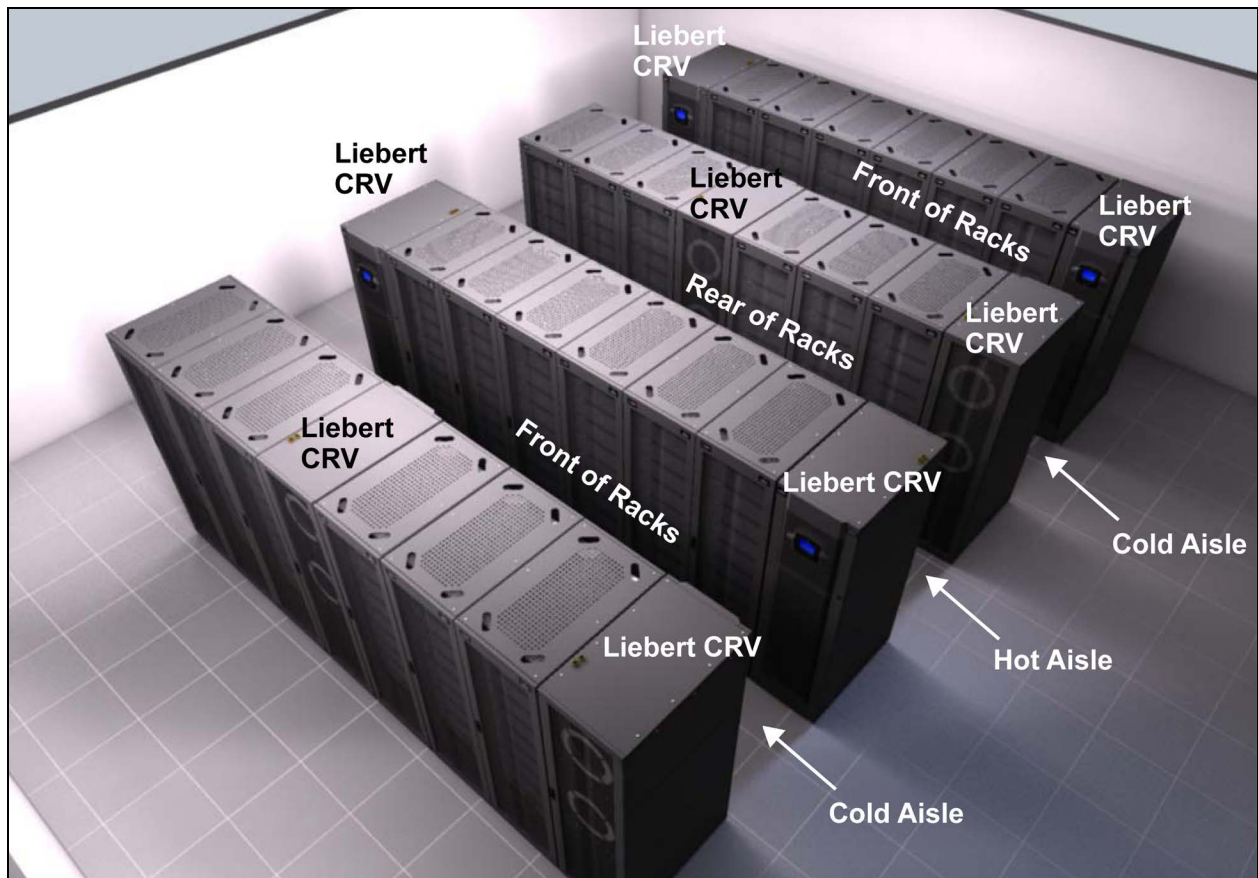

### E.1 Unit-to-Unit (U2U)—Coordinated Cooling Operation

The Liebert controls can network the Liebert® CRV units and coordinating operation to improve cooling and efficiency. In U2U mode, the networked CRVs share data from the standard temperature sensors to increase or reduce cooling. For further information, see [Standard and Optional Feature Submittals](#) on page 3.

## E.2 Placing Vertiv™ Liebert® CRV Units in Rows of Racks for Efficiency

These are examples of typical Liebert® CRV installations. For best performance, observe the following guidelines:

- Create defined hot and cold aisles. Eliminate gaps between server racks and use blanking plates to fill open sections within the racks.
- Install the 2T rack temperature sensors on the front door of all equipment that the Liebert® CRV is cooling.
- Use walls or opposing racks to minimize the width of the hot and cold aisles. Target 2 to 6 feet (0.6 to 1.8 m).

For site specific recommendations on optimizing your space for row based cooling, contact your local Vertiv representative.

### Row Placement

The Liebert® CRV can be placed either at the end of a row or in between server racks. Locating a Liebert® CRV at the end of a row helps to isolate the end of the cold aisle from the surrounding space, protecting it from hot air wrapping around the sides of the aisle. The 2T rack temperature sensors sample supply and return air temperatures.

When deploying multiple Liebert® CRV units, we recommend that you install the units at the end of rows with the baffles set to direct cold supply air toward the server equipment (Figure E.2 below). Depending on row length, heat density and airflow requirements, additional cooling units can be installed throughout the row with their baffles set to direct supply air left and right as it leaves the unit as seen in Figure E.3 on the facing page.

Cooling unit location within a row becomes less critical when deployed in Liebert® SmartRow™ containment, but we recommend that you evenly space CRVs in each row. Using room barriers, such as walls shown in Figure E.4 on the facing page, and Figure E.5 on page 54, can be very effective in simulating aisle containment. When the depth of a CRV and neighboring server rack are not the same, it is important to align the front edges of the unit with the front edges of the neighboring server racks for proper air distribution.

Figure E.2 One Liebert® CRV , Recommended Placement

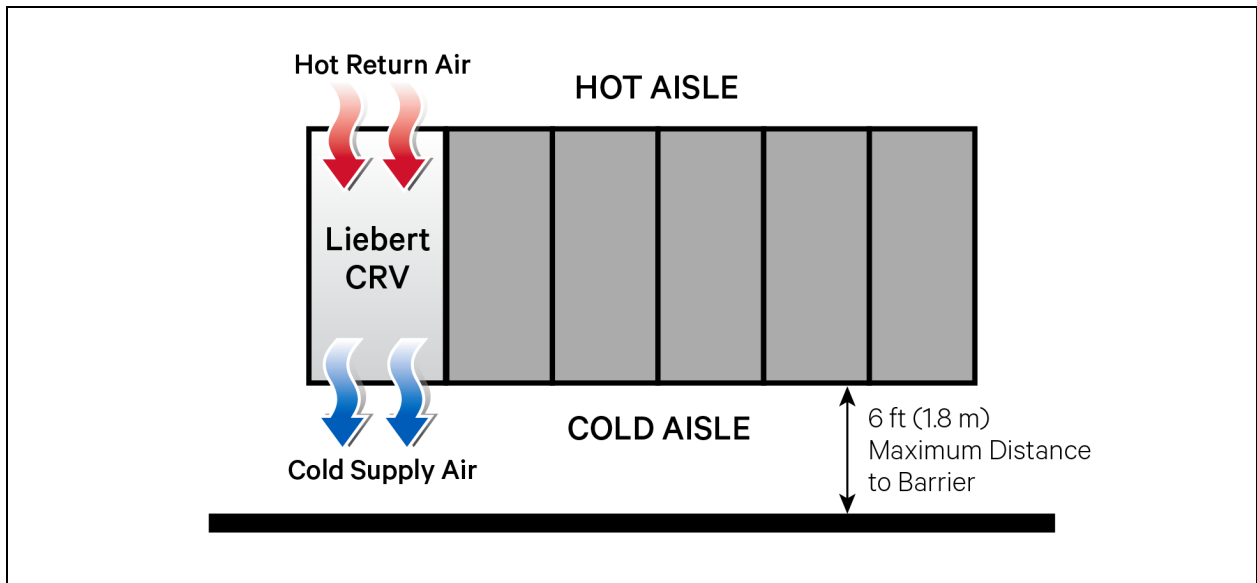



Figure E.3 One Vertiv™ Liebert® CRV, Alternate Placement

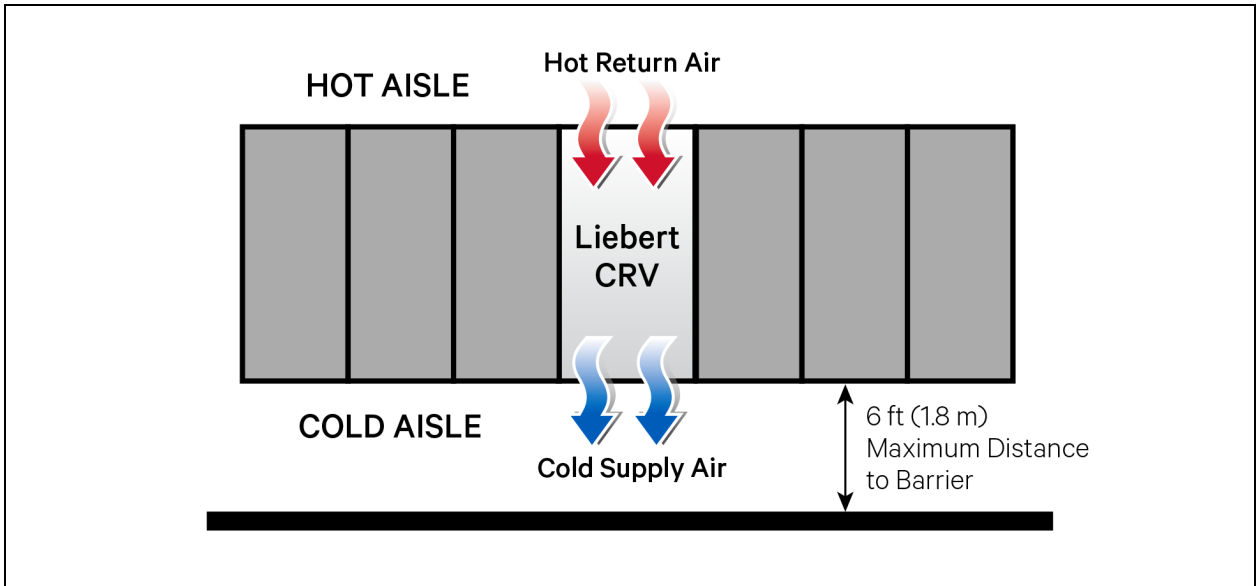

Figure E.4 Simulated Aisle Containment Using Room Barriers—Single Row

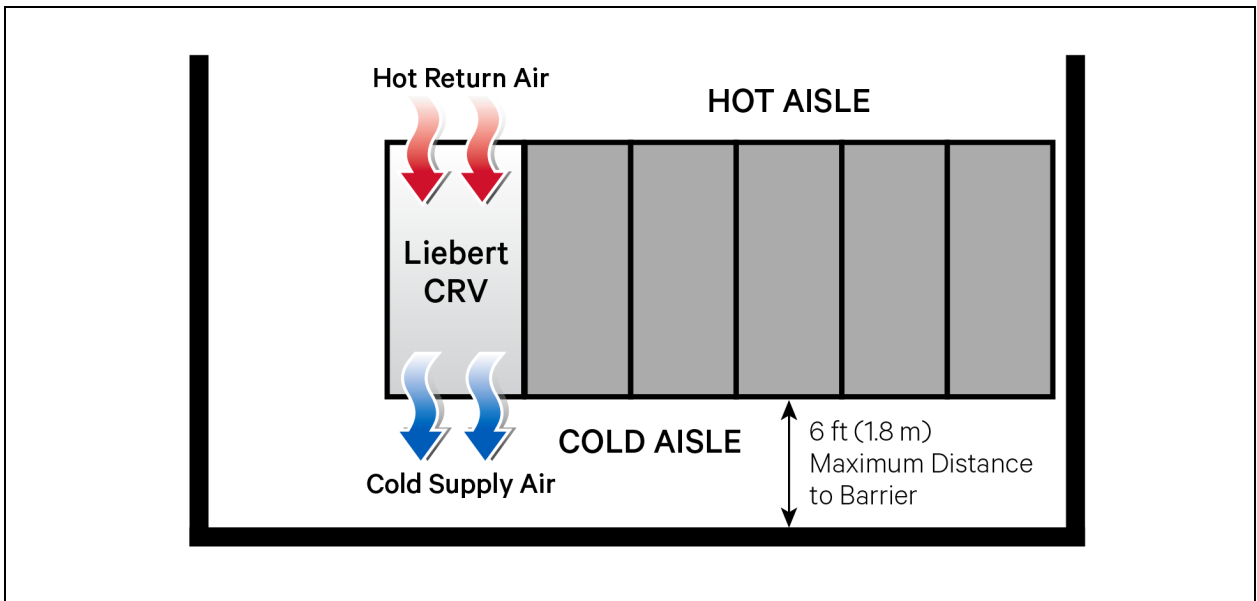
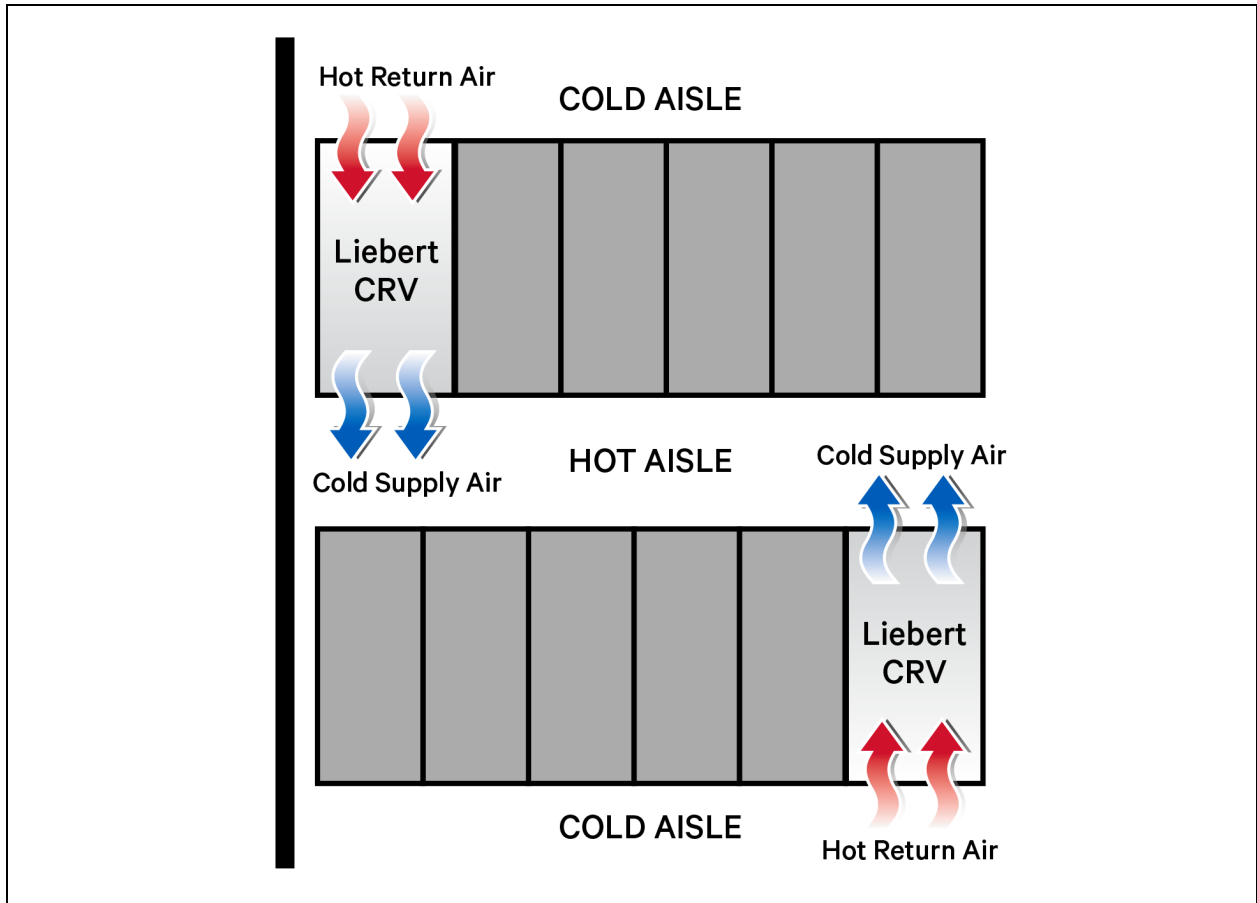

Figure E.5 Simulated Aisle Containment Using Room Barriers—Multiple Rows



### Number of Racks and Row Length

The number of racks that the Vertiv™ Liebert® CRV can condition depends on the equipment’s heat load and airflow requirements. We recommend that you oversize the CRV by approximately 20% to account for gaps where cold air is lost through server racks, obstructions (pillars, people, partly open rack doors) reducing air distribution efficiency and error in estimating server equipment heat and airflow requirements. When deployed with Liebert® SmartRow™ cold aisle containment, the CRV can be more closely matched to the server equipment needs.

When the CRV is significantly oversized, the cooling unit can effectively distribute air six to seven racks away. Initially oversizing the unit allows future data center expansion flexibility with nearly no energy consumption or footprint penalty. The intelligent Liebert® iCOM™ control and variable system components allow the unit to minimize its operation without sacrificing environmental control.

Figure E.6 Number of Racks, Row Length

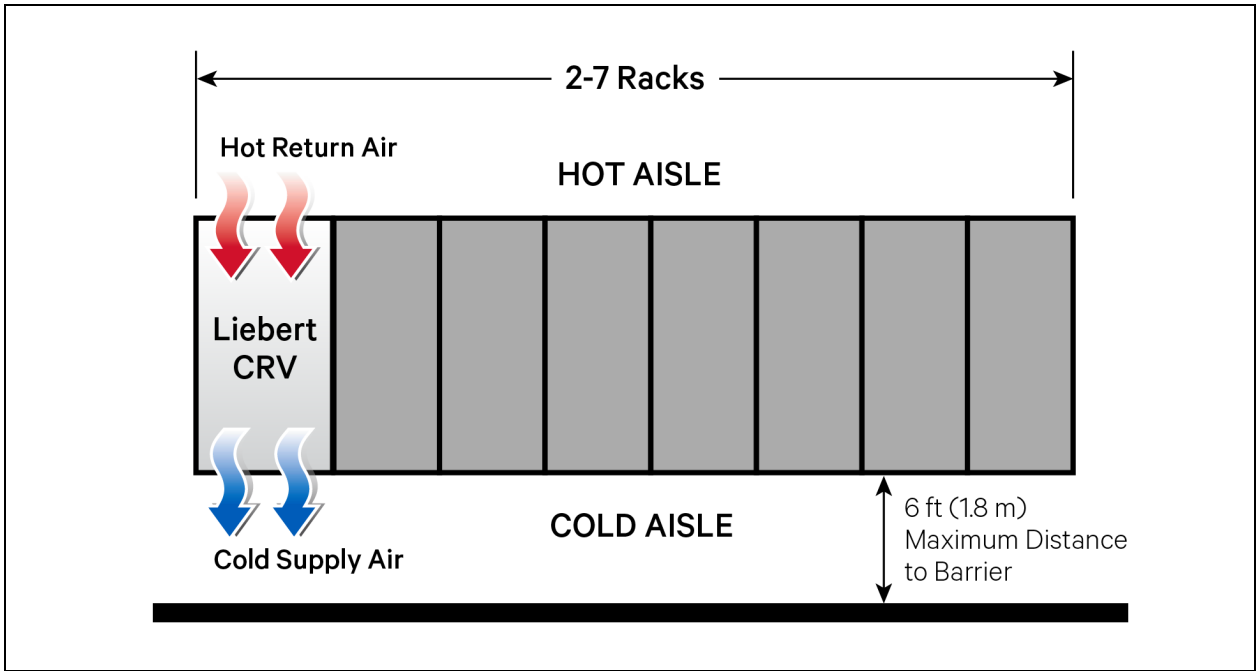

### Depth of Hot Aisle and Cold Aisle

For optimal air distribution, use opposing racks or walls to clearly define the hot and cold aisles. This helps create an efficient and effective air circulation path from the cooling unit, to the server racks, and back to the cooling unit helping to avoid loss of cold air to the room and preventing hot air from entering the cold aisle. The supply air baffle is optimized for aisle spacing of 2 to 6 feet wide.

We recommend the Vertiv™ Liebert® SmartRow™ cold aisle containment system for maximum performance. While the Vertiv™ Liebert® CRV is compatible with all forms of aisle containment, its control algorithms are optimized for partial and full cold aisle containment, allowing for increased operating efficiency and reducing the number of 2T rack sensors.

Figure E.7 Depth of Hot/Cold Aisles

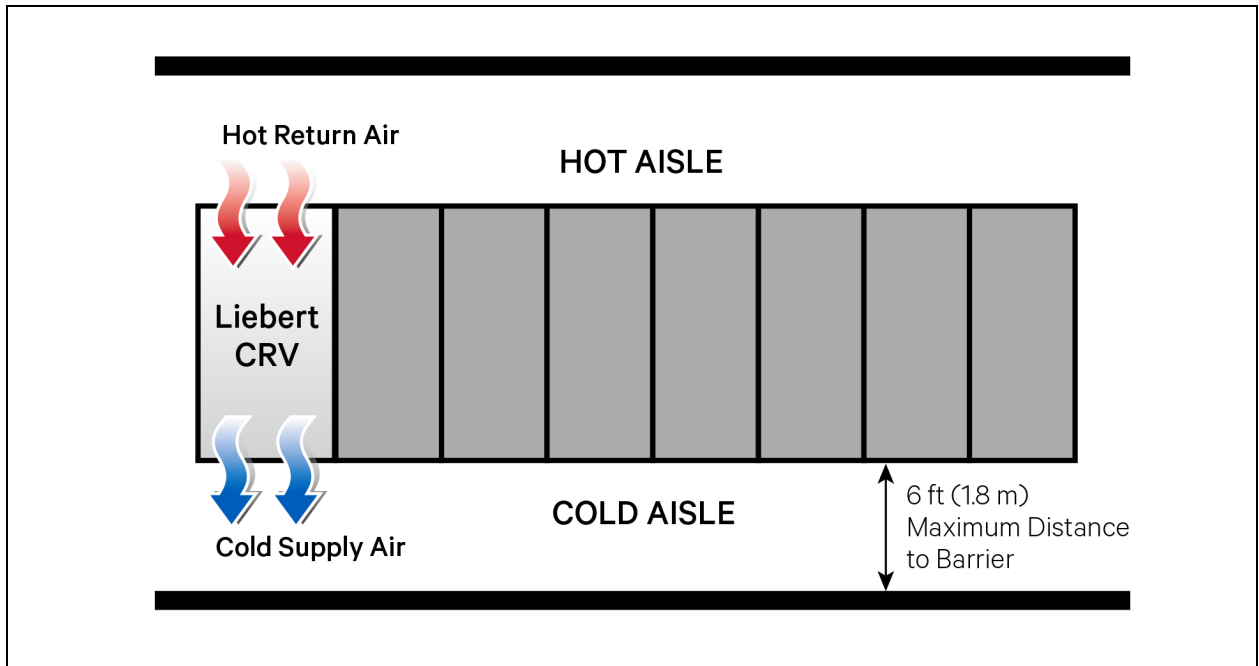

### E.3 Redundancy Arrangement

When laying out row based units for redundancy, it is better to run all units at a lower operating level than to shut off extra units. The units must be sufficiently sized to achieve the required cooling capacity if any of the other units within the same row fail. **Figure E.8** below, and **Figure E.9** on the next page, show examples of N+1 redundancy properly applied.

**Figure E.8 Example of an Application with One Row and N+1 Redundancy—Left Side Unit Failed**

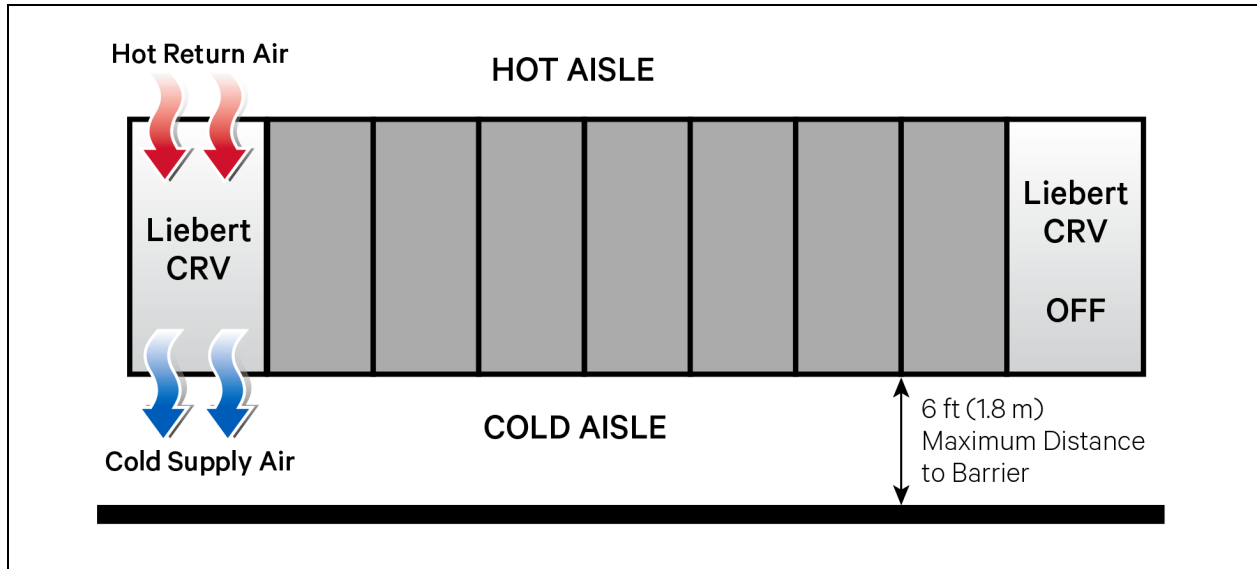
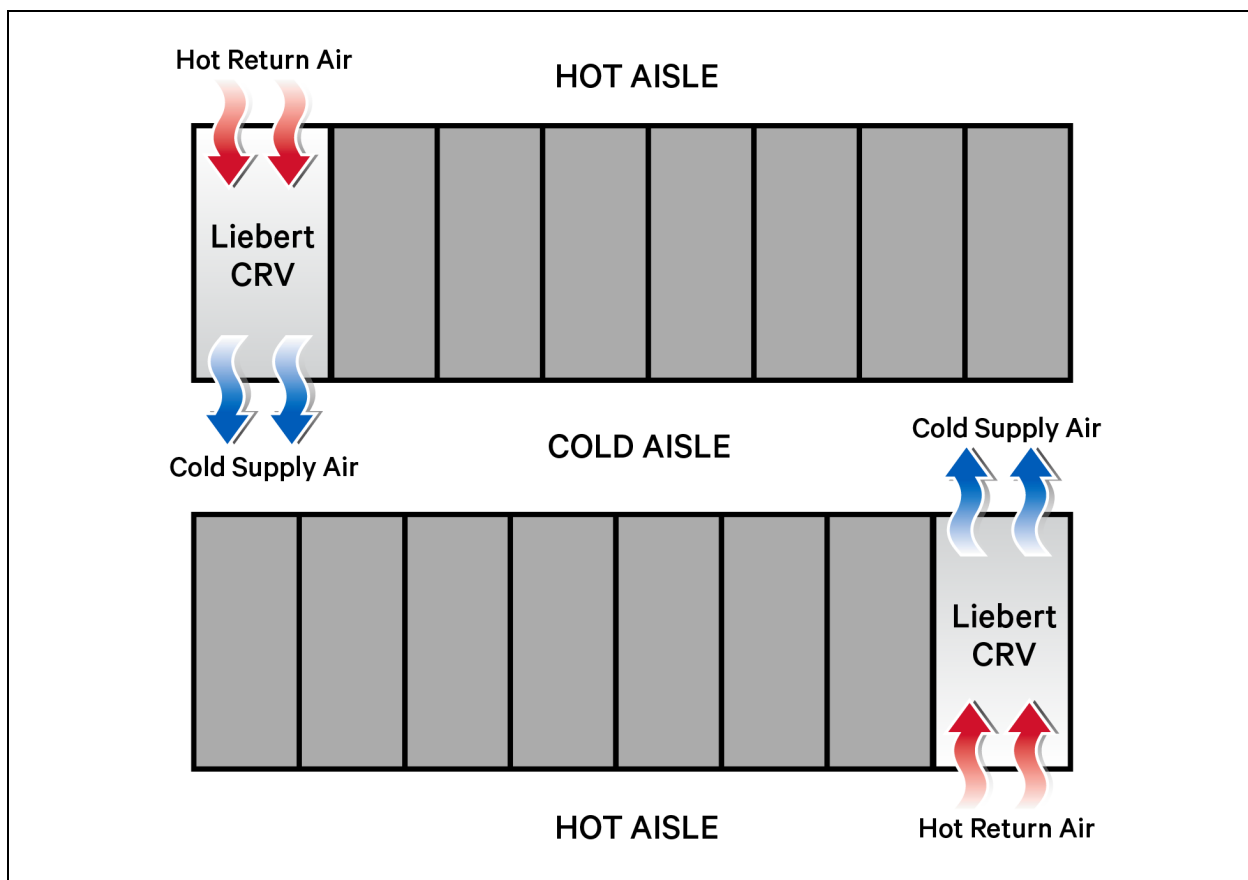

Figure E.9 Example of an Application with Two Rows and N+1 Redundancy—Unit at Lower Left Failed



## E.4 Vertiv™ Liebert® CRV Applied in Liebert® SmartRow™ Cold Aisle Containment

Using the Liebert® CRV with the Liebert® SmartRow™ is always recommended but not required. It is an excellent solution when attempting to cool widely varying heat loads, loads exceeding 10-kW per rack, and when seeking the highest efficiency systems. For additional information about the Liebert® SmartRow™, see [www.Vertiv.com](http://www.Vertiv.com).

**Figure E.10 CRV Placement with Liebert® SmartRow™ Cold Aisle Containment—Liebert® CRVs in the Center of Two Rows**

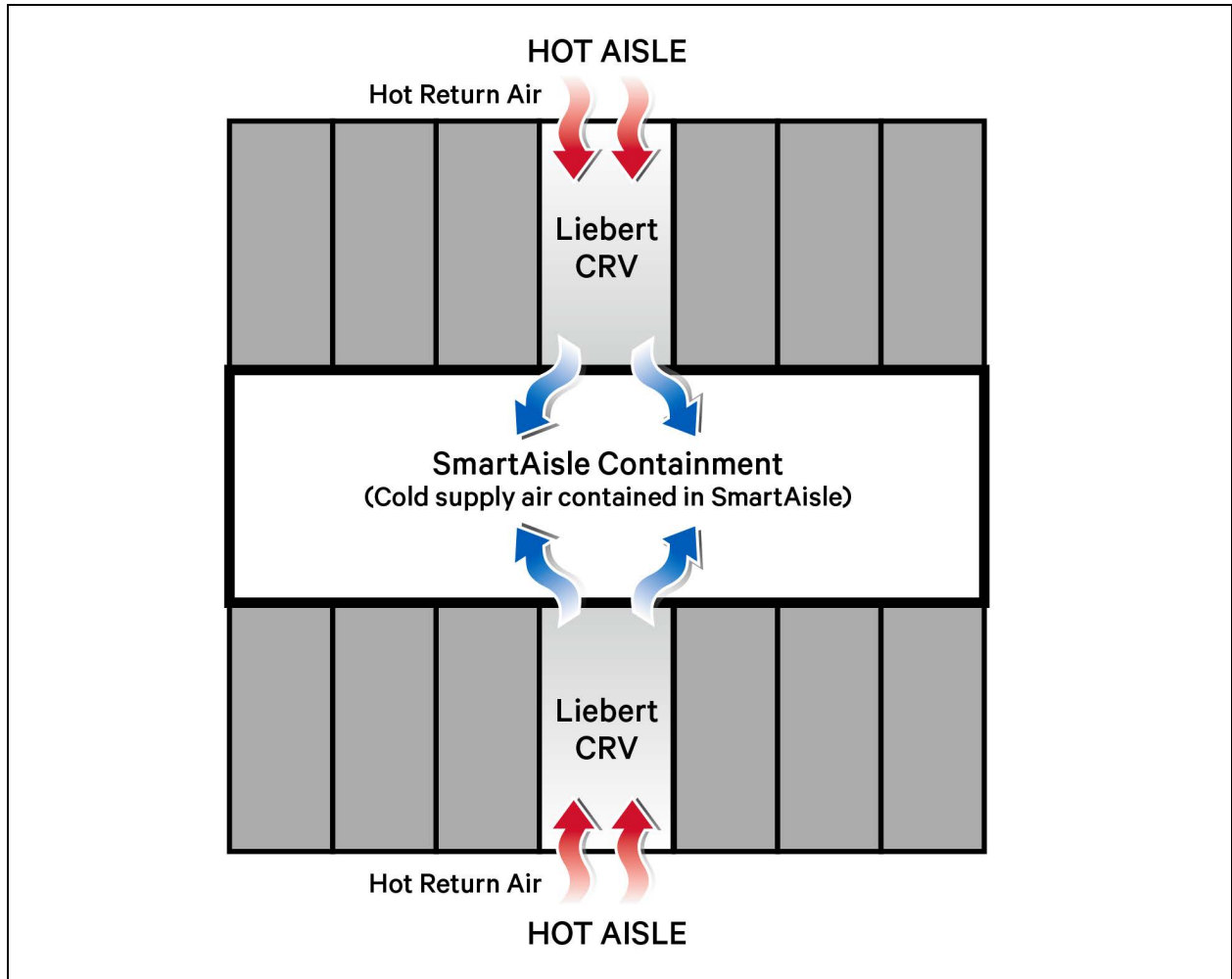
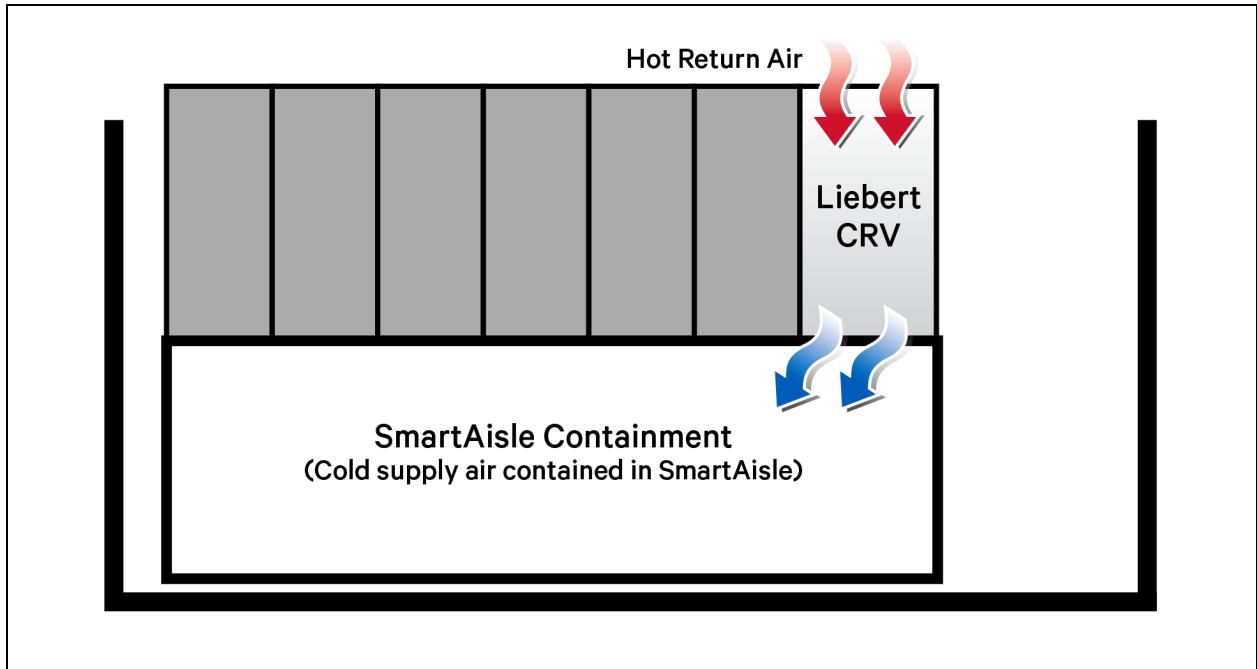

Figure E.11 Vertiv™ Liebert® CRV Placement with Liebert® SmartRow™ Cold Aisle Containment—CRV at the End of One Row





## E.5 Vertiv™ Liebert® CRV and Vertiv™ Liebert® XD Systems

When larger spaces (approximately 20 racks or more) require high density cooling, row based CRVs can be used to the support Liebert® XD cooling systems. When used together, these systems are more efficient than row based units alone.

**Figure E.12** below, illustrates the layout of a typical installation with two rows of racks and Vertiv™ Liebert® XDV modules. Two Liebert® CRV units support the Vertiv™ Liebert® XD system and provide N+1 redundant humidity control. For additional information about Liebert® XD cooling systems, see [www.Vertiv.com](http://www.Vertiv.com).

**Figure E.12** Liebert® CRV Placement with Liebert® XDVs

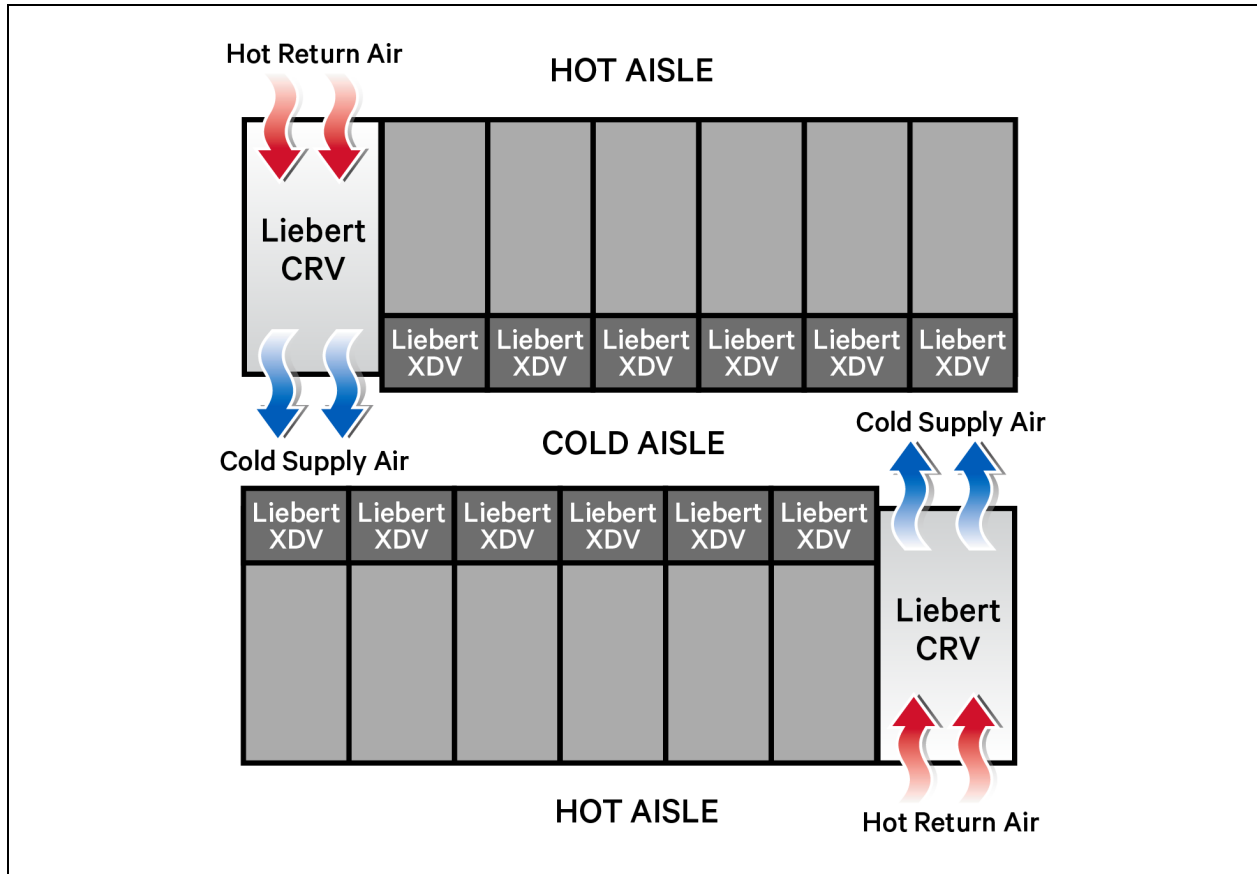

This page intentionally left blank

## Appendix F: Extra Airflow—Standard on 600 Series, Configurable on 300 Series

The Vertiv™ Liebert® CRV can provide additional airflow to correct for lower density air at higher elevations and during emergency conditions. During normal operation, the Liebert® CRV automatically modulates its airflow and cooling capacity to satisfy the aisle's requirements. The unit automatically increases the fan speed above the factory default speed during the following conditions:

- In the event that one of the two fans fail, the functioning fan will increase to maximum speed to help compensate for the lost airflow. The unit will automatically modulate its cooling capacity to avoid undesirable conditions if necessary (coil freezing and high/low refrigerant head pressure conditions).
- If a different Liebert® CRV experiences a problem that requires help from other, nearby Liebert® CRV units, the healthy units will automatically increase their fan speed above 100% to provide additional airflow and/or cooling (requires Vertiv™ Liebert® iCOM™ unit-to-unit Teamwork communication).
- If a room becomes extremely hot during a power failure when heat generating server equipment continues to run on backup power while air conditioners are without power. The Liebert® CRV will automatically utilize its extra airflow if a room is extremely hot after a power outage to cool the room back to setpoint as fast as possible.

**Table F.1 Liebert® CRV Nominal Airflow**

Model	Factory Default Rating 100% (CFM)	Maximum Fan Speed (CFM)	Extra Airflow
CRV 20kW DX	2168	2510	16%
CRV 35kW DX	2777	3725	34%
CRV 40kW CW	2880	3620	26%

Figure F.1 Nominal Airflow

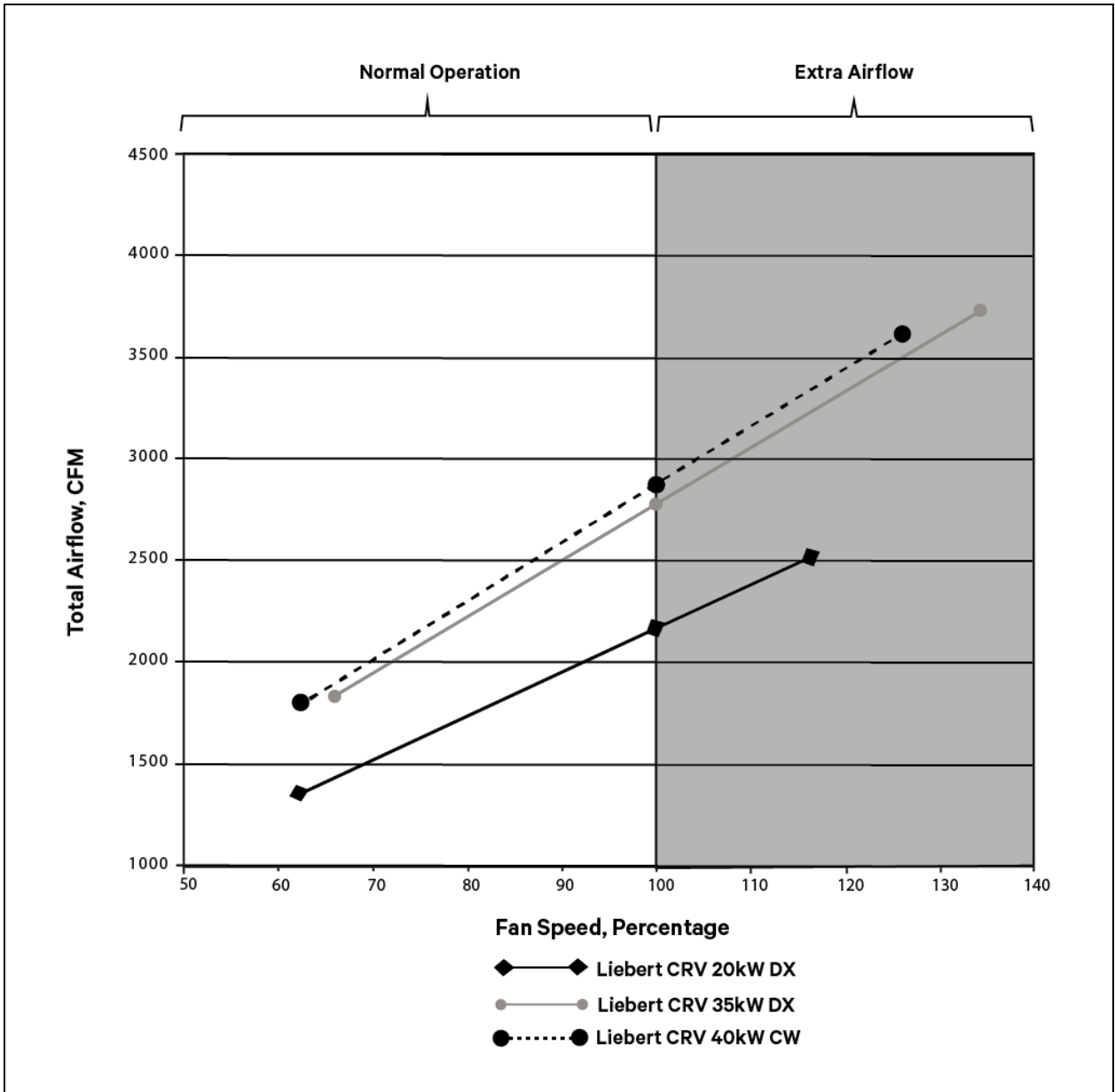

## **Appendix G: Guide Specifications**

The following are the guide specifications for the Vertiv™ Liebert® CRV.

This page intentionally left blank

# Vertiv™ Liebert® CRV Row-Based Environmental Control System Guide Specifications

## 1.0 GENERAL

### 1.1 Summary

These specifications describe requirements for a Thermal Management system. The system shall be designed to control temperature and humidity conditions in rooms containing electronic equipment, with good insulation and vapor barrier. The manufacturer shall design and furnish all equipment to be fully compatible with the heat dissipation requirements of the room.

### 1.2 Design Requirements

The Thermal Management system shall be a Liebert® self-contained, factory-assembled unit. Standard 60 Hz units shall be CSA-certified to the harmonized U.S. and Canadian product safety standard, "CSA C22.2 No 236/UL 1995 for Heating and Cooling Equipment" and are marked with the CSA c-us logo.

The system shall be AHRI Certified, the trusted mark of performance assurance for heating, ventilation, air conditioning, and commercial refrigeration equipment, using AHRI Standard 1360.

#### 1.2.1 Submittals

Submittals shall be provided with the proposal and shall include: Single-Line Diagrams; Dimensional, Electrical, and Capacity Data; Piping and Electrical Connection Drawings.

## 2.0 PRODUCT

### 2.1 Cooling System

#### 2.1.1 Air-Cooled Refrigeration System

##### Refrigeration System

The single refrigeration circuit shall include a liquid-line filter drier, a refrigerant sight glass with moisture indicator, an adjustable, externally-equalized expansion valve, and a liquid-line solenoid valve. The indoor evaporator refrigerant piping shall be spun shut with a nitrogen holding charge. Field relief of the Schrader valve shall indicate a leak-free system.

##### Hydrophilic-Coated Evaporator Coil

###### 1. Models CR020, CR035

The direct expansion, tilted-slab cooling coil shall have 7.25 ft<sup>2</sup> (0.674 m<sup>2</sup>) face area, four or five rows deep. It shall be constructed of copper tubes and hydrophilic-coated aluminum fins. The hydrophilic coating shall significantly improve the speed of condensate drainage from the fins and shall provide superior water carryover resistance. Two stainless steel condensate drain pans shall be provided.

###### 2. Model CR019

The direct expansion, slab cooling coil shall have 6.2ft<sup>2</sup> (0.576 m<sup>2</sup>) face area, three rows deep. It shall be constructed of copper tubes and hydrophilic-coated aluminum fins. The hydrophilic coating shall significantly improve the speed of condensate drainage from the fins and shall provide superior water carryover resistance. One stainless steel condensate drain pan shall be provided.

##### Compressor

The compressor shall be scroll-type with variable capacity operation from 20-100%, commonly known as a digital scroll. The compressor solenoid valve shall unload the compressor to provide variable capacity operation. The compressor shall have a suction gas-cooled motor, vibration isolators, internal thermal overloads, manual reset high-pressure switch, rotalock service valves, low-pressure and high-pressure transducer, crankcase heater, internal centrifugal oil pump and an operating speed of 3500 rpm at 60 Hz (2900rpm @ 50 Hz). The compressor shall be located outside the air stream and shall be removable and serviceable from the rear of the unit.

##### R410A Refrigerant

The system shall be designed for use with R410A refrigerant, which meets the U.S. Clean Air Act for phaseout of HCFC refrigerants.

##### Low Noise Package

The Low Noise Package shall reduce the level of sound emitted from the compressor. The package shall consist of a 3/8 inch, closed-cell polymeric 4.5 - 8.5 lb/ft<sup>3</sup> density compressor sound jacket that encloses the compressor. Additional half-inch, closed-cell polymeric 3 - 8 lb/ft<sup>3</sup> density sound-deadening material shall be affixed to the underside of the Superior Service Access Panel located above the compressor and attached to the inner side of the compressor compartment panels that face the hot and cold aisles. All sound deadening material shall be non-shedding and located outside the air stream.

#### 2.1.2 Water/Glycol-Cooled Refrigeration System

##### Refrigeration System

The single refrigeration circuit shall include a liquid-line filter drier, an adjustable externally equalized expansion valve and a liquid-line solenoid valve. The water/glycol circuit shall be equipped with an insulated, brazed-plate heat exchanger having a total pressure drop of \_\_\_\_\_ ft. (kPa) of water at a flow rate of \_\_\_\_\_ GPM (l/s) with \_\_\_\_\_ °F (°C) entering water/glycol temperature.



The water piping shall be threaded closed with a nitrogen holding charge. Field-relief of the Schrader valve shall indicate a leak-free system.

### **Hydrophilic-Coated Evaporator Coil**

#### 1. Models CR020, CR035

The direct-expansion, tilted-slab cooling coil shall have 7.25 ft<sup>2</sup> (0.674 m<sup>2</sup>) face area, four or five rows deep. It shall be constructed of copper tubes and hydrophilic-coated aluminum fins. The hydrophilic coating shall significantly improve the speed of condensate drainage from the fins and shall provide superior water carryover resistance. Two stainless steel condensate drain pans shall be provided.

#### 2. Model CR019

The direct-expansion, slab cooling coil shall have 6.2ft<sup>2</sup> (0.576 m<sup>2</sup>) face area, three rows deep. It shall be constructed of copper tubes and hydrophilic-coated aluminum fins. The hydrophilic coating shall significantly improve the speed of condensate drainage from the fins and shall provide superior water carryover resistance. One stainless steel condensate drain pan shall be provided.

### **Compressor**

The compressor shall be scroll-type with variable capacity operation from 20-100%; commonly known as a digital scroll. Compressor solenoid valve shall unload the compressor to provide variable capacity operation. The compressor shall have a suction gas-cooled motor, vibration isolators, internal thermal overloads, manual reset high-pressure switch, rotalock service valves, low-pressure and high-pressure transducer, crankcase heater, internal centrifugal oil pump, and an operating speed of 3500 rpm at 60 Hz (2900rpm @ 50 Hz). The compressor shall be located outside the air stream and shall be removable and serviceable from the rear of the unit.

### **R410A Refrigerant**

The system shall be designed for use with R410A refrigerant, which meets the U.S. Clean Air Act for phaseout of HCFC refrigerants.

### **Low Noise Package**

The Low Noise Package shall reduce the level of sound emitted from the compressor. The package shall consist of a 3/8-inch, closed-cell polymeric 4.5 - 8.5 lb/ft<sup>3</sup> density compressor sound jacket that encloses the compressor. Additional half-inch, closed-cell polymeric 3 - 8 lb/ft<sup>3</sup> density sound-deadening material shall be affixed to the underside of the Superior Service Access Panel located above the compressor and attached to the inner side of the compressor compartment panels that face the hot and cold aisles. All sound deadening material shall be non-shedding and located outside the air stream.

### **Modulating Valve**

#### 1. Two-Way

A two-way modulating valve shall control the water/glycol flow through the insulated, brazed-plate condenser. The Vertiv™ Liebert® iCOM™ shall manage the valve actuator movement to maintain the desired condensing temperature for various entering water temperatures. The maximum differential pressure across the closed valve shall be 43.5 PSI (300 kPa). Maximum system pressure shall be 230 PSI (1,586 kPa).

#### 2. Three-Way

A three-way modulating valve shall control the water/glycol flow through the insulated, brazed-plate condenser. The Liebert® iCOM™ shall manage the valve actuator movement to maintain the desired condensing temperature for various entering water temperatures. The maximum differential pressure across the closed valve shall be 43.5 PSI (300 kPa). Maximum system pressure shall be 230 PSI (1586 kPa).

### Brazed-Plate Heat Exchanger

The heat exchanger shall be an insulated, brazed-plate type. The primary side shall be piped to a chilled water source, and the secondary side shall be connected to the refrigeration system. A strainer must be installed upstream of the Vertiv™ Liebert® CRV, on the primary (building) chilled water side.

## 2.1.3 Chilled Water System

The water circuit shall be designed to distribute water into the entire coil face area.

### Hydrophilic-Coated Evaporator Coil

#### 1. Model CR040

The chilled water tilted-slab cooling coil shall be 7.25 ft<sup>2</sup> (0.674m<sup>2</sup>) face area, six rows deep. It shall be constructed of copper tubes and hydrophilic-coated aluminum fins. The hydrophilic coating shall significantly improve the speed of condensate drainage from the fins and shall provide superior water carryover resistance. Two stainless steel condensate drain pans shall be provided. The water circuit shall be threaded shut with a nitrogen holding charge. Field-relief of the Schrader valve shall indicate a leak-free system.

#### 2. Model CR032

The chilled water, rotated-slab cooling coil shall be 7.8ft<sup>2</sup> (0.72m<sup>2</sup>) face area, three rows deep. It shall be constructed of copper tubes and hydrophilic-coated aluminum fins. The hydrophilic coating shall significantly improve the speed of condensate drainage from the fins and shall provide superior water carryover resistance. A stainless-steel condensate drain pan shall be provided. The water circuit shall be threaded shut with a nitrogen holding charge. Field-relief of the Schrader valve shall indicate a leak-free system.

### Modulating Valve

#### 1. Two-Way Valve

A two-way modulating valve shall control the chilled water flow through the cooling coil. The Vertiv™ Liebert® iCOM™ shall manage the valve actuator movement to provide the desired amount of cooling for various entering water temperatures. Cooling capacity shall be regulated by varying the chilled water flow. The maximum differential pressure across the closed valve shall be 200 PSI (1379 kPa). Maximum system pressure shall be 325 PSI (2,241 kPa).

#### 2. Three-Way Valve

A three-way modulating valve shall control the chilled water flow passing through the cooling coil. The Liebert® iCOM™ shall manage the valve actuator movement in order to provide the desired amount of cooling for various entering water temperatures. Cooling capacity shall be regulated by varying the chilled water flow. The maximum differential pressure across the closed valve shall be 200 PSI (1,379 kPa). Maximum system pressure shall be 325 PSI (2,241 kPa).

## 2.2 Fan Section

#### 1. Models CR020, CR035, CR040

The unit shall be equipped with two plug fans: direct-driven centrifugal fans with backward-curved blades and electronically-commutated DC motors; commonly referred to as EC plug fans. The fan speed shall be variable and automatically regulated by the Liebert® iCOM™ through all modes of operation. Each fan shall have a dedicated motor, fault monitoring circuitry and speed controller which provides a level of redundancy. The impellers shall be made of steel and balanced. The EC plug fans shall be mounted on the rear door. The entire fan assembly shall be capable of swinging out of the unit for accessibility. The fans shall be located to blow air through the filters and tilted-slab cooling coil to ensure even air distribution and maximum coil performance.

## 2. Model CR019

The unit shall be equipped with five plug fans: direct-driven centrifugal fans with backward-curved blades and electronically commutated DC motors; commonly referred to as EC plug fans. The fan speed shall be variable and automatically regulated by the Vertiv™ Liebert® iCOM™ through all modes of operation. Each fan shall have a dedicated motor, fault monitoring circuitry and speed controller, which provides a level of redundancy. The impellers shall be made of steel and balanced. The EC plug fans shall be mounted in the front of the unit and draw air through the coil.

## 3. Model CR032

The unit shall be equipped with six plug fans: direct-driven centrifugal fans with backward-curved blades and electronically commutated DC motors; commonly referred to as EC plug fans. The fan speed shall be variable and automatically regulated by the Liebert® iCOM™ through all modes of operation. Each fan shall have a dedicated motor, fault monitoring circuitry and speed controller, which provides a level of redundancy. The impellers shall be made of steel and balanced. The EC plug fans shall be mounted in the front of the unit and draw air through the coil.

## 2.3 Advanced Airflow Management

### 2.3.1 Supply Air Baffle System

#### 1. Models CR020, CR035, CR040

A field-adjustable, modular, supply-air baffle system shall be located in the discharge air stream on the front of the cabinet to direct air toward the equipment racks and balance air-flow requirements within the row. The six modular baffle segments shall be easily reconfigurable to redirect air flow as cooling requirements change. Controlling the air flow prevents hot spots and maintains high return-air temperatures by not blowing cold air over racks or out the ends of aisles. By focusing the cold air where it is needed and meeting the servers' requirements, the need for excessive air flow and energy consumption is eliminated.

#### 2. Models CR019, CR032

A field-adjustable, modular, supply-air baffle system shall be located in the discharge air stream on the front of the cabinet to direct air toward the equipment racks and balance air-flow requirements within the row. The five modular baffle segments shall be easily reconfigurable to redirect air flow as cooling requirements change. Controlling the air flow prevents hot spots and maintains high return-air temperatures by not blowing cold air over racks or out the ends of aisles. By focusing the cold air where it is needed and meeting the servers' requirements, the need for excessive airflow and energy consumption is eliminated.

## 2.4 Cabinet Construction and Accessibility

### 2.4.1 Cabinet Construction

#### 1. Models CR020, CR035, CR040

The exterior panels shall be 20-gauge steel and powder-coated with charcoal color paint to protect against corrosion. The double-wall side panels separate the half-inch, 2.0 lb./ft<sup>3</sup> insulation from the air stream and increase unit rigidity. The unit shall be mounted on casters for quick installation and provided with leveling feet. The perforated inlet and outlet panels shall have 81% open area. The rear door shall utilize a Vertiv™ Liebert® Knürr™ rack style handle and hinges to mirror the appearance of neighboring server racks.

## 2. Model CR019, CR032

The exterior panels of the unit shall be 20-gauge steel and powder-coated with charcoal color paint to protect against corrosion and follow Vertiv™ Knürr™ rack appearance guidelines to mirror the style of neighboring equipment racks. The cabinet shall be mounted on casters for quick installation and provided with leveling feet. Both doors shall have a powder-coated sheet-metal frame with hexagonal perforations leaving 81% of the door open to air flow for efficient cooling. The front and rear doors shall swing 170 degrees open, shall be removable, and shall feature a two-point latch. The powder-coat painted steel side panels shall be lined with half-inch closed-cell polymeric insulation and secured using quarter-turn fasteners.

### 2.4.2 Serviceability

The cabinet shall be designed so all components are easily accessible for service and maintenance through either the front or rear of the unit. Units that are not fully accessible from front and rear or not serviceable in place shall be unacceptable.

#### 1. Models CR020, CR035, CR040

The Superior Service Access Panel shall provide additional access to the top of the system components. Side access shall not be required.

The variable-speed EC plug fans shall be mounted on the rear door to provide access to all sides when swung out of the unit. Units with a compressor, dual-float condensate pump, and canister humidifier shall have components conveniently mounted near the edge of the unit.

#### 2. Model CR019, CR032

Side access shall not be required. Each of the variable-speed fans shall be individually replaceable through the front door of the unit. Units with a compressor and/or a condensate pump shall be conveniently mounted near the edge of the unit.

### 2.4.3 Supply Air Baffle System

#### 1. Models CR020, CR035, CR040

A field-adjustable, modular, supply-air baffle system shall be located in the discharge air stream on the front of the cabinet to direct air toward the server racks and balance air-flow requirements within the row. The six modular baffle segments shall be easily reconfigurable to redirect air flow as cooling requirements change. Controlling the air flow prevents hot spots and maintains high return-air temperatures by not blowing cold air over racks or out the ends of aisles. By focusing the cold air where it is needed and meeting the rack equipment's cooling requirements, the need for excessive air flow and energy consumption is eliminated.

#### 2. Models CR019, CR032

A field-adjustable, modular, supply-air baffle system shall be located in the discharge air stream on the front of the cabinet to direct air toward the server racks and balance air-flow requirements within the row. The five modular baffle segments shall be easily reconfigurable to redirect airflow as cooling requirements change. Controlling the air flow prevents hot spots and maintains high return-air temperatures by not blowing cold air over racks or out the ends of aisles. By focusing the cold air where it is needed and meeting the rack equipment's cooling requirements, the need for excessive air flow and energy consumption is eliminated.

## 2.5 Locking Disconnect Switch

#### 1. Models CR020, CR035, CR040

A manual disconnect switch shall be mounted in the electrical panel and be capable of disrupting the flow of power to the unit. The electric-panel compartment shall be accessible only with the switch in the Off position. It shall be located behind the Vertiv™ Liebert® iCOM™ display door for quick access.

2. Models CR019, CR032

A manual disconnect switch shall be mounted in the electrical panel and be capable of disrupting the flow of power to the unit. The electric-panel compartment shall be accessible only with the switch in the Off position. It shall be located behind the rear door for quick access.

## 2.6 Short Circuit Current Rating (SCCR)

1. Models CR019, CR020, CR035, CR040

The electrical panel shall provide at least 65,000A SCCR.

2. Model CR032 120V/1/60Hz

The electrical panel shall provide at least 5000A SCCR.

3. Model CR032 208-230/1/60Hz

The electrical panel shall provide at least 65,000A SCCR.

4. Model CR032 208-230/3/60Hz

The electrical panel shall provide at least 65,000A SCCR.

5. Model CR032 460/3/60Hz

The electrical panel shall provide at least 65,000A SCCR.

## 2.7 Filtration

1. Models CR020, CR035, CR040

- a. MERV 8

The filter channel shall be an integral part of the system, located within the cabinet and serviceable from the rear. The two filters shall be deep-pleated, 4 inches thick with an ASHRAE 52.2 MERV8 rating (30% ASHRAE 52.1). A filter clog alarm shall be included. Mesh type, cleanable filters shall be unacceptable.

- b. MERV 11

The filter channel shall be an integral part of the system, located within the cabinet and serviceable from the rear. The two filters shall be deep-pleated, 4 inches thick with an ASHRAE 52.2 MERV11 rating (60-65% ASHRAE 52.1). A filter clog alarm shall be included. Mesh type, cleanable filters shall be unacceptable.

2. Models CR019, CR032

- a. MERV 1

The two filters shall be an integral part of the system, located within the cabinet and serviceable from the rear. The filters shall be washable, half-inch thick with an ASHRAE 52.2 MERV1 rating. A filter clog alarm shall be included.

- b. MERV 8

The two filters shall be an integral part of the system, located within the cabinet and serviceable from the rear. The filters shall be washable, half-inch thick with an ASHRAE 52.2 MERV8 rating. A filter clog alarm shall be included.

### 2.7.1 Extra Filter Set (Optional)

\_\_\_\_\_ extra set(s) of filters shall be provided per system.

## 2.8 Electric Reheat

The low-watt density, 304/304, stainless-steel, finned-tubular electric reheat coils shall be capable of maintaining room dry bulb conditions when the system is calling for dehumidification. The reheat section shall include UL/CSA recognized safety switches to protect the system from overheating. The capacity of the reheat coils shall be controlled in one stage. The reheat elements shall be accessible from the front of the cabinet.

## 2.9 Steam Generating Canister Humidifier

A canister-type steam-generating humidifier shall be factory-installed in the cooling unit and operated by the Vertiv™ Liebert® iCOM™. It shall be complete with disposable cylinder, all supply and drain valves, steam distributor and electronic controls. The need to change the canister shall be indicated on the Liebert® iCOM™. The humidifier shall be designed to operate with water conductivity from 330 to 670 (60 Hz) microS/cm. The system shall automatically fill and drain as well as maintain the required water level based on conductivity. An air gap within the humidifier assembly shall prevent back-flow of the humidifier supply water. The humidifier canister shall be removable from the rear of the cabinet.

## 2.10 Condensate Pump—Models CR020, CR035, CR040

The dual-float condensate pump shall have a minimum capacity of \_\_\_\_ GPM (\_\_\_\_ l/min) at \_\_\_\_ ft. (\_\_\_\_ m) head. The pump shall be complete with integral primary and secondary float switches, pump, motor assembly and reservoir. The secondary float shall send a signal to the local alarm and shut down the unit upon high water condition.

## 2.11 Condensate Pump—Models CR019

The dual-float condensate pump shall have a minimum capacity of \_\_\_\_ GPM (\_\_\_\_ l/min) at \_\_\_\_ ft. (\_\_\_\_ m) head. The pump shall be complete with integral primary and secondary float switches, pump, motor assembly and reservoir. The secondary float shall send a signal to the local alarm and shut down the unit upon high water condition.

## 2.12 Condensate Pump—Models CR032

The dual-float condensate pump shall have a minimum capacity of \_\_\_\_ GPM (\_\_\_\_ l/min) at \_\_\_\_ ft (\_\_\_\_ m) head. The pump shall be complete with integral primary and secondary float switches, pump, motor assembly, and reservoir. The secondary float shall send a signal to the local alarm and shut down the unit upon high water condition.

## 2.13 IBC/OSHPD Seismic Certification - CRV600mm (24 in.) and CRV300mm (12 in.)

IBC/OSHPD Seismic Certification shall be provided with applicable bracing and field installation instructions. Vertiv™ Liebert® CRV units shall bear a label certifying compliance with IBC/OSHPD requirements.

## 3.0 CONTROL

### 3.1 Vertiv™ Liebert® iCOM™ Microprocessor Control with 9 Inch Color Touchscreen

The Liebert® iCOM™ shall be microprocessor-based with a 9" color touchscreen display and shall be mounted in an ergonomic, aesthetically pleasing housing. The controls shall be menu driven. The system shall display user menus for active alarms, event log, graphic data, unit view/status overview (including the monitoring of room conditions, operational status in percentage of each function, date, and time), total run hours, various sensors, display setup, and service contacts. A password shall be required to make system changes. Service menus shall include setpoints, standby settings (lead/lag), timers/sleep mode, alarm setup, sensor calibration, maintenance/wellness settings, options setup, system/network setup, auxiliary boards, and diagnostics/service mode.

- **Password Protection** - The Liebert® iCOM™ shall contain two unique passwords to protect against unauthorized changes. An auto hide/show feature shall allow the user to see applicable information based on the login used.
- **Unit Backup and Restore** - The user shall be able to create safe copies of important control parameters. The Liebert® iCOM™ shall have the capacity for the user to automatically backup unit configuration settings to internal memory or USB storage drive. Configuration settings may be transferred to another unit for a more stream-lined unit start-up.
- **Parameter Download** - The Liebert® iCOM™ shall enable the user to download a report that lists parameter names, factory default settings and user programmed settings in .csv format for remote reference.
- **Parameter Search** - The Liebert® iCOM™ shall have search fields for efficient navigation and parameter lookup.
- **Setup Wizards** - The Liebert® iCOM™ shall contain step-by-step tutorials or wizards to provide easy setup of the control.
- **Context-Sensitive Help** - The Liebert® iCOM™ shall have an on-board help database. The database shall provide context-sensitive help to assist with setup and navigation of the menus.
- **Display Setup** - The user shall be able to configure the display information based on the specific user's preference. Language, units of measure, screen contrast, home screen layout, back-light timer, and the hide/show of certain readouts shall be configurable through the display.
- **Additional Readouts** - The display shall enable the user to configure custom widgets on the main screen. Widget options will include items such as fan speed, call for cooling, call for free-cooling, maintenance status, call for hot water reheat, call for electric reheat, call for dehumidification, call for humidification, airflow, static pressure, fluid flow rate and cooling capacity.
- **Status LED's** - The Liebert® iCOM™ shall show the unit's operating status using an integral LED. The LED shall indicate if the unit has an active alarm; if the unit has an active alarm that has been acknowledged; or if the unit is On, Off or in standby status.
- **Event Log** - The Liebert® iCOM™ shall automatically store the last 400 unit-only events (messages, warnings, and alarms).
- **Service Contact Information** - The Liebert® iCOM™ shall be able to store the local service or sales contact information.
- **Upgradeable** - Liebert® iCOM™ upgrades shall be performed through a USB connection.
- **Timers/Sleep Mode** - The menus shall allow various customer settings for turning the unit On or Off.

- **Menu Layout** - The menus shall be divided into two main menus: User and Service. The User screen shall contain the menus to access parameters required for basic unit control and setup. The Service screen shall be designed for service personnel and shall provide access to advanced control setup features and diagnostic information.
- **Sensor Calibration** - The menus shall allow unit sensors to be calibrated with external sensors.
- **Maintenance/Wellness Settings** - The menus shall allow reporting of potential component problems before they occur.
- **Options Setup** - The menus shall provide operation settings for the installed components.
- **Auxiliary Boards** - The menus shall allow setup of optional expansion boards.
- **Diagnostics/Service Mode** - The Vertiv™ Liebert® iCOM™ control shall be provided with self-diagnostics to aid in troubleshooting. The microcontroller board shall be diagnosed and reported as pass/not pass. Control inputs shall be indicated as On or Off at the front display. Control outputs shall be able to be turned On or Off from the front display without using jumpers or a service terminal. Each control output shall be indicated by an LED on a circuit board.

### 3.2 Alarms

All unit alarms shall be annunciated through both audio and visual cues, clearly displayed on the screen, automatically recorded in the event log, and communicated to the customers Building Management System/Building Automation System. The Liebert® iCOM™ shall activate an audible and visual alarm in event of any of the following conditions:

- High Temperature
- Low Temperature
- High Humidity
- Low Humidity
- EC Fan Fault
- Change Filters
- Loss of Air Flow
- Loss of Power
- Humidifier Problem
- High Head Pressure
- Low Suction Pressure
- Custom Alarms

Custom alarm inputs shall be provided to indicate facility-specific events. Custom alarms can be identified with programmable labels. Frequently used alarm inputs include:

- Leak Under Floor
- Smoke Detected
- Standby Unit On

Each alarm (unit and custom) shall be separately enabled or disabled, selected to activate the common alarm and programmed for a time delay of 0 to 255 seconds.



### 3.3 Vertiv™ Liebert® iCOM™ Control Methods and Options

The Liebert® iCOM™ shall be factory-set to allow precise monitoring and control of the condition of the air entering and leaving the unit. This control shall include predictive methods to control air flow and cooling capacity-based control sensors installed. Proportional and Tunable PID shall also be user-selectable options.

### 3.4 Controlling Sensor Options

Liebert® iCOM™ shall be flexible in the sense that it shall allow for controlling the capacity and fan from multiple different sensor selections. The sensor selections shall be:

#### Cooling Capacity

- Supply
- Remote
- Return

#### Fan Speed

- Supply
- Remote
- Return
- Manual (for diagnostic or to receive a signal from the BMS through the Liebert® remote monitoring devices or analog input).

#### 3.4.1 Temperature Compensation

The Liebert® iCOM™ shall be able to adjust the capacity output based on supply and return temperature conditions to meet SLA guidelines while operating to highest efficiency.

#### 3.4.2 Humidity Control

Dew point and relative humidity control methods shall be available (based on user preference) for humidity control within the conditioned space.

### 3.5 Multi-Unit Co-ordination

Liebert® iCOM™ teamwork shall save energy by preventing multiple units in an area from operating in opposing modes. Teamwork allows the control to optimize a group of connected cooling units equipped with Liebert® iCOM™ using the U2U (Unit-to-Unit) network. There shall be three modes of teamwork operation:

- **Teamwork Mode 1:** Is best in small rooms with balanced heat loads. The controlling temperature and humidity sensor readings of all units in operation (fan on) are collected to be used for an average or worst-case sensor reading (user selectable). The master unit shall send the operating requirements to all operating units in the group. The control band (temperature, fan, and humidity) is divided and shared among the units in the group.
- **Teamwork Mode 2:** The Liebert® iCOM™ calculates the worse-case demand for heating, cooling humidification and dehumidification. Based on the greatest demand within the group, each unit operates independently, meaning that the unit may respond to the thermal load and humidity conditions based on the unit's controlling sensors.

- **Teamwork Mode 3 - Optimized Aisle:** May be employed in large and small rooms with varying heat loads. Optimized Aisle is the most efficient teamwork mode that allows the unit to match cooling capacity with heat load. In the Optimized Aisle mode, the fans operate in parallel. Fans can be controlled exclusively by remote temperature or using static pressure with a secondary remote temperature sensor(s) as an override to ensure that the inlet rack temperature is being met. Cooling (Compressors) is controlled through unit supply-air conditions. Vertiv™ Liebert® iCOM™ calculates the average or worst-case sensor reading (user-selectable) for heating, cooling humidification, and dehumidification. Based on the demand within the group, units will be allowed to operate within that mode until room conditions are satisfied.

### 3.6 Standby Lead - Lag

The Liebert® iCOM™ shall allow scheduled rotation to keep equal run time on units and provide automated emergency rotation of operating and standby units.

### 3.7 Standby Unit Cascading

The Liebert® iCOM™ cascade option shall allow the units to turn On and Off based on heat load when utilizing Optimized Aisle, Teamwork Mode 3 and remote temperature sensors. Cascade mode dynamically coordinates the fan speed to save energy and to meet the cooling demands. For instance, with a Liebert® iCOM™ group of six units and only 50% of the heat load, the Liebert® iCOM™ shall operate only four units at 80% fan speed and leave the other two units in standby. As the heat load increases, the Liebert® iCOM™ shall automatically respond to the additional load and bring on another unit, increasing the units in operation to five. As the heat load shifts up or down, the control shall meet the needs by cascading units On or putting them into standby.

### 3.8 Wired Supply Sensor

Each Liebert® iCOM™ shall have one factory-supplied and connected supply-air sensor that may be used as a controlling sensor or reference. When multiple sensors are applied for control purposes, the user shall be able to control based on a maximum or average temperature reading.

### 3.9 Virtual Master

As part of the robust architecture of the Liebert® iCOM™ control, it shall allow for a virtual master that coordinates operation. The Virtual Master function shall provide smooth control operation if the group's communication is compromised. When the lead unit, which is in charge of component staging in teamwork, unit staging and standby rotation, becomes disconnected from the network, the Liebert® iCOM™ shall automatically assign a virtual master. The virtual master shall assume the same responsibilities as the master until communication is restored.

### 3.10 Compressor Short Cycle Control

To help maximize the life of the compressor, there shall be start-to-next start delay for the compressor. The control shall monitor the number of compressor starts in an hour. If the compressor starts more than 10 times in 60 minutes, the local display and remote monitoring shall notify the user through a Compressor 1 Short Cycle event.

### 3.11 Vertiv™ Liebert® MC

Units may be matched to a premium efficiency condenser control with enhanced monitoring, alarming, and diagnostics. The condenser control shall have an automated, low-noise mode and fan reversal for cleaning mode.

### 3.12 System Auto Restart

The auto restart feature shall automatically restart the system after a power failure. Time delay shall be programmable.

### 3.13 Sequential Load Activation

On initial start-up or restart after power failure, each operational load shall be sequenced with a minimum delay of one second to minimize total inrush current.

### 3.14 Low Pressure Monitoring

Units shall ship standard with low-pressure transducers for monitoring compressor suction pressure. If the pressure falls due to loss of charge or other mechanical cause, the corresponding circuit shall shut down to prevent equipment damage. The user shall be notified of the low-pressure condition through the local display and remote monitoring.

### 3.15 Winter Start Time Delay - Air - Cooled Models

An adjustable software timer shall be provided to assist with compressor starting during cold weather. When the compressor starts, the low-pressure input shall be ignored for the period set in the user-adjustable timer. Once the time period has elapsed after the compressor start, the low-pressure input should remain in the normal state. If the low-pressure input does not remain in the normal state when the time delay has elapsed, the circuit shall lock out on low pressure. The low-pressure alarm shall be announced on the local display and communicated to remote monitoring systems.

### 3.16 Advanced Freeze Protection

Units shall ship standard with advanced freeze protection enabled. The advanced freeze protection shall monitor the pressure of the circuit using a transducer. The control shall interact with the fan and compressor to prevent the unit coil from freezing if circuit suction pressure drops. If a freeze condition is detected, the user shall be notified through the local display and remote monitoring systems.

### 3.17 Advanced High - Pressure Protection - Water/Glycol Cooled Models with Digital Scroll Compressors

When the compressor is initially activated, the system shall be monitored for high pressure. When high pressure is detected, the control shall alter the compressor operation to reduce the system discharge pressure, preventing circuit shut down. If the unit is unsuccessful in correcting the problem through this interaction, an alarm shall occur, and the affected compressor shall be immediately locked off. The control shall re-enable the compressor when the pressure returns to a safe level.

### 3.18 Refrigerant Pressure Transducer Failure

The control shall monitor the high-side and low-side refrigerant pressure transducers. If the control senses the transducer has failed, has been disconnected, has shorted or the reading has gone out of range, the user shall be notified through an event on the local display and remote monitoring. The corresponding circuit that the failure has occurred on shall be disabled to prevent unit damage.

### 3.19 Oil Return Protection

The control shall monitor compressor operation and staging to ensure that liquid and hot gas velocity are maintained for proper oil return to the compressor.

### 3.20 Digital Scroll High Temperature Protection

The control shall monitor digital scroll temperature during unit operation. A compressor temperature limit shall be imposed to help prevent damage to the compressor. If the temperature reaches the maximum temperature limit, the compressor shall be locked out and an alarm shall be annunciated on the local display and through monitoring. After the initial lockout, the control shall continue to monitor compressor temperature during the off-cycle and re-enable the circuit once a safe operating temperature is reached. The control shall store the number of high temperature trips. The number of trips shall be accessible through the local display.

### 3.21 Digital Scroll Sensor Failure

The control shall monitor the status of the digital scroll sensor. If the control senses that the thermistor is disconnected, shorted or the reading goes out of range, the user shall be notified through an event on the local display and remote monitoring.

### 3.22 Compressor High and Low Temperature Limit Protection

The control shall monitor the return air to ensure that the compressor(s) are operated within the manufacturer's defined window of operation. If the return air temperature deviates from the manufacturer's window of operation, the Vertiv™ Liebert® iCOM™ shall automatically adjust to prevent damage to the cooling unit or reduction in its reliability.

### 3.23 Compressor Run Time Monitoring

The control shall log these compressor statistics:

- Number of compressor starts
- Run hours
- Average run time
- Starts per day
- Starts per day worst
- Number of high-pressure alarms
- Operating phase in which the high-pressure alarm occurred
- Number of low-pressure alarms
- Operating phase in which the low-pressure alarm occurred
- Number of high-temperature alarms

The user shall have the ability to monitor compressor operating temperature and pressure from the local display to be used as a diagnostic tool.

### 3.24 Rack Temperature Sensors

The Vertiv™ Liebert® CRV shall be provided with three Vertiv™ Liebert® 2T Rack temperature sensors, each consisting of a vented case with two temperature probes. The sensors shall provide real-time, direct feedback to the cooling unit to optimize the amount of cooling and airflow provided. The sensor data shall be available to remote BMS and monitoring systems. The sensor network shall consist of one CAN wire leaving the cooling unit and connecting to a 2T sensor. Each remaining 2T sensor is connected to the previous sensor.

#### 3.24.1 Additional Rack Temperature Sensor(s)

\_\_\_\_\_ additional 2T rack temperature sensors shall be provided.

#### 3.24.2 Additional CAN Cables for Rack Sensors

\_\_\_\_\_ additional \_\_\_\_ feet long CAN cables shall be provided.

### 3.25 Vertiv™ Liebert® vNSA Network Switch-Optional

The Liebert® vNSA network switch is designed for networking multiple Vertiv™ Liebert® iCOM™ unit-level controllers together. There shall be two different styles of the Liebert® vNSA14 panel available:

- Liebert® vNSA14 – enclosure with network switches only
- Liebert® vNSA14, Liebert® iCOM™ H – enclosure with network switches and 9" Liebert® iCOM™ color touchscreen display.

Each offering shall be housed inside a steel enclosure secured with a key lock and contain two network switches, providing a total of 14 Ethernet ports available for Liebert® iCOM™ controller unit-to-unit networking. The Liebert® vNSA requires field supplied, hard wiring, 16AWG, 100-240VAC universal (12V, 1.5A) single-phase input power supply for 120V or 230V operation with factory supplied power connector.

### 3.26 Communication Interfaces

#### 3.26.1 Remote Shutdown Terminal

The remote shutdown terminal shall provide a location to remotely shut down the unit, complying with the National Fire Code.

#### 3.26.2 Common Alarm Contact

The common alarm contact shall provide a set of normally open contacts for remote indication of unit alarms.

#### 3.26.3 Vertiv™ Liebert® CRV 600mm Cabinet Reheat/Humidifier Lockout

The reheat and humidifier lockout shall include the necessary relays to disable the reheat and humidifier from an external 24V signal while on emergency power.

#### 3.26.4 Liebert® CRV 600mm Cabinet (Model 20, 35 and 40) One Extra Common Alarm Contact

One additional contact (total of two sets) of normally open (n/o) contacts for remote indication of unit alarms shall be provided.

#### 3.26.5 Vertiv™ Liebert® IntelliSlot™ Unity-DP Card

The Liebert® IntelliSlot™ Unity Card (IS-UNITY-DP) shall provide ground fault isolated RS-485 Modbus, BACnet IP and Modbus IP network connectivity to Building Management Systems for unit monitoring and management. Also, it shall provide ground fault isolated 10/100 baseT Ethernet connectivity for unit monitoring and management. The supported management interfaces include SNMP for Network Management Systems, HTTP for Web page viewing, SMTP for e-mail and SMS for mobile messaging. The card shall support IP and 485 protocols simultaneously.

#### 3.26.6 Vertiv™ Liebert® IntelliSlot™ SiteLink-E Card

The Liebert® IntelliSlot™ SiteLink-E Card shall provide ground fault isolated connection to a Vertiv™ Liebert® SiteLink-E for monitoring and management. Liebert® IntelliSlot™ SiteLink-E supports Vertiv interfaces as a BACnet router that provides the communication link between Liebert® units and other protocols and modules. The Liebert® SiteLink-E is de-signed to communicate with Liebert® equipment—cooling units, UPSs and PDUs—and route the information over a BACnet, Vertiv™ Liebert® Modbus or Vertiv™ Liebert® LONWorks network to a Building Automation System (BAS) workstation. This shall be required for communication with Vertiv™ Liebert® SiteScan™ Web 4.0 or newer.

### 3.26.7 Vertiv™ Liebert® Nform (Optional Advanced Monitoring)

The Critical Infrastructure Management software shall centrally monitor and manage distributed equipment using the customer's existing network infrastructure. The system shall provide the Critical Infrastructure Management and Monitoring for air conditioning (CRAC) systems, uninterruptible power supply (UPS) systems, power distribution units (PDUs), static transfer switches (STS), direct current power systems (DC), power distribution strips (PDU), Vertiv™ Liebert® Alber™ battery monitoring, rack enclosure monitoring, leak detection systems, and other critical infrastructure systems as specified. The system shall have an architecture that allows up to 10,000 managed devices, including Liebert® and third-party devices, in a single-server installation.

#### System Requirements

All material and equipment used shall be standard components, regularly manufactured and available and not custom-designed especially for this project. All systems and components shall have previously been thoroughly tested and proven in actual use before installation on this project.

The manufacturer will furnish or supply a site-specific Critical Infrastructure Management software system based on customer requirements. The system must be a software-only solution; no substitutions shall be accepted.

The system architecture shall consist of network interface cards that shall be installed in all critical infrastructures that, at a minimum, support HTTP and SNMP simultaneously.

The system shall receive SNMP traps from managed equipment and display the alarm notification in a graphical user interface.

The system shall be based on SNMP open protocols and shall integrate seamlessly with Vertiv™ Liebert® Aperture™ software suite and Network Management Systems.

Open protocol support shall include:

- HTTP(s)
- TCP/IP/v4, TCP/IP/v6
- SNMPv1, SNMPv2

The system shall have the capability of being remotely monitored and managed 24 hours a day, 7 days a week by the manufacturer.

The system shall have the ability to be deployed worldwide.

The system shall operate as a client-to-server application.

The Web interface of each managed device shall integrate directly into the system.

The system shall support enterprise-level databases including Microsoft SQL.

The system shall support exporting of all recorded parametric trend data.

The system shall operate on a server determined by the customer. Specific server brand or function is not permissible.

The system shall support virtual server environments by default.

The system shall include, at no additional cost, one (1) year of Software Assurance.

#### Approved Products

The Critical Infrastructure Monitoring System shall be Vertiv™ Liebert® Nform as manufactured by Vertiv. No substitutions shall be accepted.

## Scope of Work

### 1. Owner-Supplied Items

The owner shall furnish the following system components:

- Network (LAN) hardware and software required to provide an Ethernet backbone to be used for transport of IP data packets from network interface cards installed in all equipment to the Critical Infrastructure server and to the Vertiv™ Liebert® Nform workstations. These components may include hubs, routers, cabling, network operating systems, firewalls, IP addresses, virtual private network (VPN), and other components as required. The owner shall supply network drops for the Critical Infrastructure server, workstation clients, and all network-interfaced equipment.
- Dedicated Critical Infrastructure server meeting the following minimum requirements:
  - Microsoft Windows 7, XP, 2003, Windows Vista or Windows Server 2008 operating system
  - Pentium 3.0 GHz single processor or better (1.8 GHz dual processor or better recommended)
  - 4 GB of RAM (memory) or better
  - 40 GB hard drive (SCSI recommended)
  - 10/100 BaseT network port or better
  - Monitor/keyboard and mouse port as required for setup
  - Standard USB ports
  - CD or DVD-ROM drive for software installation (CD/DVD-RW suggested for installation and backup)
  - Critical Infrastructure server may be Virtual Environment compatible
- Critical Infrastructure Workstation PCs meeting the following minimum requirements:
  - System should meet the minimum requirements for Microsoft Windows 7, XP, 2003, Vista or Server 2008 operating systems.
  - Microsoft Internet Explorer v6.0 or higher
  - 1 GB RAM
  - Hard disk with 10 GB free space

The owner shall supply the following to facilitate system implementation:

- IP addresses and subnet masks and other information as required to configure network devices
- A person as the nominated system owner for administrator purposes
- Secure location for hardware and server

### Critical Infrastructure System Vendor Responsibilities

Provide hardware and software as listed.

- Critical Infrastructure software and licenses for server and workstation installations.
- Software Assurance for the first year at no additional cost.
- 7 x 24 system application and service support through a toll-free telephone number.
- Warranty (parts and labor) per the manufacturer's warranty statement.
- Vendor shall be ISO 9001 listed for design and manufacture of environmental control systems for Critical Monitoring and Control applications.

#### 3.26.8 Vertiv™ Liebert® Liqui-Tect™ 410 Point Leak Detection Sensor for Remote Mounting

A total of \_\_\_\_\_ (quantity) solid-state water sensor(s) with no moving parts and hermetically sealed to keep out dust and dirt shall be provided. The Liebert® Liqui-Tect™ 410 (LT410) shall provide a single-point detection of leaks. The point detection sensor shall have two gold-plated sensing probes to prevent corrosion resistance and to provide accurate readings. The LT410 shall constantly monitor points for leaks, internal faults and power failures and warn of any abnormal conditions. Mounting brackets shall allow for sensor height adjustment and leveling. The LT410 shall provide two independent outputs to signal both a local alarm panel and a remote building management system or external equipment. The LT410 shall be rated for 24VAC, 50/60Hz and 0.10 amp.

#### 3.26.9 Liebert® Liqui-tect™ 460 Zone Leak Detection Module with Cable Kit for Remote Mounting

A total of \_\_\_\_\_ (quantity) zone water sensor cables with no moving parts and hermetically sealed to keep out dust and dirt shall be provided. The Liebert® Liqui-Tect™ 460 (LT460) shall provide a zone detection of leaks. The LT460 shall constantly monitor points for leaks, internal faults and power failures and warn of any abnormal conditions. LED's shall provide status indication and also ensure the cable is properly installed and operational under raised floors. The LT460 shall provide two independent outputs provide a signal to a local alarm panel, Liebert® environmental unit, remote building management system or external equipment.

##### 1. Liebert® Liqui-tect™ 460 Module

The LT460 shall consist of a metal enclosure with a hinged top door providing access to the internal circuit board for wiring termination and configuration of DIP switches. The LT460 shall monitor up to 100 feet (30m) of connected LT500Y leak detection cable. The LT460 shall be rated for 24VAC, 50/60Hz and 0.12A.

##### 2. LT500Y Leak Detection Cable

The cable material and construction shall allow the cable to lie flat when used with hold-down clips. The LT500Y shall be plenum-rated and UL-listed for safe operation. Cables shall be available in lengths of 20, 25, 30, 35 and 45 feet (6, 7.6, 9, 10.6 and 13.7m).



## 4.0 HEAT REJECTION

### 4.1 Options—Air Cooled Vertiv™ Liebert® MC Condenser

#### 4.1.1 Standard Features

The condenser shall consist of microchannel condenser coil(s), propeller fan(s) direct driven by individual fan motor(s), electrical controls, housing, and mounting legs. The Liebert® air-cooled condenser shall provide positive refrigerant head pressure control to the indoor cooling unit by adjusting heat rejection capacity. Microchannel coils shall provide superior heat transfer, reduce air side pressure drop, increase energy efficiency, and shall significantly reduce the system refrigerant volume required. EC fans and fan operating techniques shall provide reduced maximum sound levels. Various methods shall be available to match indoor unit type, maximum outdoor design ambient, and maximum sound requirements.

#### 4.1.2 Condenser Coil

##### Aluminum Microchannel Coil

Liebert® microchannel coils shall be constructed of aluminum microchannel tubes, fins, and manifolds. Tubes shall be flat and contain multiple, parallel flow microchannels and span between aluminum headers. Full-depth, louvered aluminum fins shall fill spaces between the tubes. Tubes, fins, and aluminum headers shall be oven-brazed to form a complete refrigerant-to-air heat exchanger coil. Copper stub pipes shall be electric resistance welded to aluminum coils and joints protected with polyolefin to seal joints from corrosive environmental elements. Coil assemblies shall be factory leak tested at a minimum of 300 psig (2068 kPag). Hot gas and liquid lines shall be copper and shall be brazed using nitrogen gas flow to the stub pipes with spun-closed ends for customer piping connections. Complete coil/piping assembly shall be then filled and sealed with an inert gas holding charge for shipment.

##### Aluminum Microchannel Coil with E-Coat

Aluminum microchannel coil with E-coat shall be epoxy-coated for extended coil life in corrosive environments, such as coastal areas. Factory-applied E-coat using immersion and baking process shall provide a flexible epoxy-coating to all coil surfaces. Coil color shall be black and shall be protected from solar UV ray degradation with a factory-applied UV topcoat. E-coat shall increase coil corrosion protection and shall reduce heat rejection capacity degradation to less than 10% after a severe 2000-hour 5% neutral salt spray test (ref. ASTM B117). The coating process shall ensure complete coil encapsulation.

#### 4.1.3 Fan Motor/Blade Assembly

The fan motor/blade assembly shall have an external rotor motor, fan blades and fan/finger guard. Fan blades shall be constructed of cast aluminum or glass-reinforced polymeric material. Fan guards shall be heavy gauge, close-meshed steel wire, coated with a black, corrosion-resistant finish. Fan terminal blocks shall be located in an IP54 enclosure located on the top of the fan motor. Fan assemblies shall be factory-balanced, tested before shipment and mounted securely to the condenser structure.

##### EC Fan Motor

The EC fan motors shall be electronically commutated for variable speed operation and shall have ball bearings. The EC fans shall provide internal overload protection through built-in electronics. Each EC fan motor shall have a built-in controller and communication module, linked via RS-485 communication wire to each fan and the Premium Control Board, allowing each fan to receive and respond to precise fan speed inputs from the Premium Control Board.

#### 4.1.4 Electrical Controls

Electrical controls and service connection terminals shall be provided and factory-wired inside the attached control panel section. A locking disconnect switch shall be factory-mounted and wired to the electrical panel and controlled via an externally mounted locking and lockable door handle. Only high-voltage supply wiring and low-voltage indoor unit communication/interlock wiring shall be required at condenser installation.

##### Premium Control

The EC fan/Premium Control System shall include an electronic control board, EC fan motor(s) with internal overload protection, refrigerant and ambient temperature thermistors, and refrigerant pressure transducers. The control board shall receive an indoor unit run signal via field-supplied low voltage interlock wires to the compressor side switch via field-supplied CANbus communication wires from the indoor unit's Vertiv™ Liebert® iCOM™ or via both. The control board shall use sensor and communication inputs to maintain refrigerant pressure by controlling each EC fan on the same refrigerant circuit to the same speed.

##### Locking Disconnect

A locking-type disconnect switch shall be factory-mounted and wired to the electrical panel. The switch shall be accessible from the outside of the unit with the door closed and shall prevent access to the high-voltage electrical components until switched to the Off position. The locking disconnect shall be lockable in support of lockout/tag-out safety programs.

##### Short Circuit Current Rating

The electrical panel shall provide at least 65,000A SCCR.

##### 575V Option

The secondary electrical enclosure shall contain a factory wired transformer and fusing to support 575V input power. All internal wiring shall be provided to connect main and secondary electrical enclosures. High-voltage supply and low voltage indoor unit communication/interlock connections shall be made in the main electrical enclosure.

#### 4.1.5 Cabinet

The condenser cabinet shall be constructed of bright aluminum sheet and divided into individual fan sections by full width baffles. Internal structural support members, including the coil support frame, shall be galvanized steel for strength and corrosion resistance. Panel doors shall be provided on two sides of each coil/fan section to permit coil cleaning. An electrical panel shall be contained inside a factory mounted, NEMA 3R weatherproof electrical enclosure. Units with the 575V option shall include a second factory mounted, NEMA 3R weatherproof electrical enclosure opposite the main electrical enclosure.

#### 4.1.6 Mounting Legs

##### Standard Legs

Legs shall be provided to mount the unit for vertical air discharge with rigging holes for hoisting the unit into position. Standard height shall be 18 in. (457 mm).

##### Optional Galvanized Steel Legs with Bracing

Condensers shall be shipped with (36 in. [914 mm]) (48 in. [1219 mm]) (60 in. [1524 mm]) mounting legs with stabilization bracing. Legs, bracing, and hardware shall be galvanized steel.

## 4.1.7 Condenser Accessories

### Vertiv™ Liebert® Lee-Temp Receiver Kit

Liebert® Lee-Temp Receiver Kit shall contain an insulated, heated receiver tank with sight glasses, mounting plate, mounting hardware, pressure relief valve, rotalock valve for refrigerant charge isolation and piping assembly with head pressure operated three-way valve and check valve. Components shall be field assembled to the condenser. The three-way valve shall sense refrigerant head pressure and adjust the flooding charge in the condenser coil to adjust the condenser heat rejection capacity.

### Fusible Plug Kit

A fusible plug kit shall be field installed on the liquid line for compliance with building codes requiring refrigerant relief during high temperature and building fire conditions.

### IBC/OSHPD Seismic Certification and IBC Wind/Snow Load Compliant

IBC/OSHPD Seismic Certification and IBC Wind/Snow Load Compliant condensers shall be provided with any applicable bracing and field installation instructions. Condensers shall bear a label certifying compliance with IBC/OSHPD requirements.

## 4.2 Optional - Vertiv™ Liebert® Drycooler

### 4.2.1 Liebert® Drycooler Summary

These specifications describe requirements for a Liebert® Air-Cooled drycooler for a Liebert® Thermal Management system. The drycooler shall be designed to reject waste heat to outdoor air and to control glycol temperature as pumped glycol rates and outdoor ambient conditions change.

The manufacturer shall design and furnish all equipment in the quantities and configurations shown on the project drawings.

Standard 60-Hz units shall be CSA-certified to the harmonized U.S. and Canadian product safety standard CSA C22.2 No 236/UL 1995 for "Heating and Cooling Equipment" and shall be marked with the CSA c-us logo.

### 4.2.2 Liebert® Design Requirements

The Liebert® drycooler shall be a factory-assembled unit, complete with integral electrical panel, designed for outdoor installation and vertical air flow only. The drycooler shall be a draw-through design.

### 4.2.3 Liebert® Drycooler Standard Features - All Drycoolers

The Liebert® drycooler shall consist of drycooler coil(s), housing, propeller fan(s) direct driven by individual fan motor(s), electrical controls, and mounting legs. The Liebert® air-cooled drycooler shall provide glycol temperature control to the indoor cooling unit by adjusting heat-rejection capacity. Various methods shall be available to match indoor unit type, minimum outdoor design ambient and maximum sound requirements.

### 4.2.4 Liebert® Drycooler Coil

The Liebert® manufactured coil shall be constructed of copper tubes in a staggered tube pattern. Tubes shall be expanded into continuous, corrugated aluminum fins. The fins shall have full-depth fin collars completely covering the copper tubes, which shall be connected to heavy wall Type "L" headers. Inlet-coil connector tubes shall pass through relieved holes in the tube sheet for maximum resistance to piping strain and vibration. Coil shall be split-flow into multiple coil circuits, combined to yield a Liebert® drycooler with \_\_\_\_\_ internal circuits. The supply and return lines shall be (spun shut [1 to 4 fan models]), (brazed with a cap [6 or 8-fan models]) and shall include a factory-installed Schrader valve. Coils shall be factory leak-tested at a minimum of 300 psig (2068 kPag), dehydrated, then filled and sealed with an inert-gas holding charge for shipment. Field relief of the Schrader valve shall indicate a leak-free coil.

#### 4.2.5 Housing

The Liebert® drycooler housing shall be constructed of bright aluminum sheet and divided into individual fan sections by full-width baffles. Structural support members, including coil support frame, motor, and drive support, shall be galvanized steel for strength and corrosion resistance. Aluminum legs shall be provided to mount unit for vertical air discharge and shall have rigging holes for hoisting the unit into position. An electrical panel shall be inside an integral NEMA 3R weatherproof section of the housing.

#### 4.2.6 Propeller Fan

The propeller fan shall have aluminum blades secured to a corrosion-protected steel hub. Fans shall be secured to the fan-motor shaft by means of a keyed hub and dual set screws. Fan diameter shall be 26 in. (660 mm) or less. Fans shall be factory-balanced and run before shipment. Fan guards shall be heavy gauge, close-mesh steel wire with corrosion-resistant polyester-paint finish that shall be rated to pass a 1000-hour salt spray test.

#### 4.2.7 Fan Motor

The fan motor shall be continuous air-over design and shall be equipped with a rain shield and permanently-sealed bearings. Motors shall be rigidly mounted on die-formed galvanized-steel supports.

#### 4.2.8 Electrical Controls

Electrical controls, overload-protection devices and service-connection terminals shall be provided and factory-wired inside the integral electrical-panel section of the housing. A locking disconnect switch shall be factory-mounted and wired to the electrical panel and controlled via an externally-mounted, locking door handle. An indoor-unit interlock circuit shall enable Liebert® drycooler operation whenever indoor-unit compressors are active. Only supply wiring, indoor-unit interlock wiring and high-voltage wiring to pumps when controlled by the Liebert® drycooler shall be required at drycooler installation.

#### 4.2.9 Pump Controls Control within Drycooler

##### Single Pump Option

Pump controls for a single glycol pump up to 7.5 hp (5.6 kW) shall be incorporated into the same integral electrical panel as the Liebert® drycooler fan controls and may include fuses or circuit breakers as required for the pump motor. Pump voltage, phase and frequency shall be same as Liebert® drycooler voltage, phase, and frequency.

##### Dual Pump Option

Pump controls for a dual glycol pump system up to 7.5 hp (5.6 kW) shall operate one pump as primary and the second pump shall operate as a stand-by pump. Pump controls shall be incorporated into the same integral electrical panel controlling Liebert® drycooler fans. A factory-supplied, field-installed flow switch shall sense loss of flow and switch to the stand-by pump for continuous system operation. An internal switch shall allow manual selection of the primary (lead) pump.

#### 4.2.10 Pump Package

##### Single Pump Package

This system shall be provided with a centrifugal pump mounted in a weatherproof and vented enclosure. The pump shall be rated for \_\_\_ GPM (\_\_\_ l/m) at \_\_\_ ft. (\_\_\_ kPa) of head and operate on \_\_\_ volt, 3-phase, \_\_\_ Hz.

##### Dual Pump Package

The dual pump package shall include pumps, enclosure, and field-mounted flow switch. The standby pump shall automatically start up on failure of the lead pump by Liebert® drycooler pump controls or by a separate factory-wired control box and shall include a lead/ lag switch for the pumps. Each pump shall be rated for \_\_\_\_\_ GPM (\_\_\_ l/s) at \_\_\_ ft. (\_\_\_ kPa) of head.

#### 4.2.11 Ancillary Items

An expansion tank shall be provided for expansion and contraction of the glycol fluid due to temperature change in the closed system. The tank and air vents shall be field installed at the system's highest elevation to allow venting of trapped air. A fluid-pressure relief valve shall be provided for system safety. The system shall include (tank-steel [expansion, compression, diaphragm, bladder], air separator, air vent, fluid-pressure relief valve, pressure gages, flow switches, tempering valves, [primary, primary and stand-by] pumps, supply and return piping).

## 5.0 EXECUTION

### 5.1 Installation of Thermal Management Units

#### 5.1.1 General

Install cooling units in accordance with manufacturer's installation instructions. Install units plumb and level, firmly anchored in locations indicated and maintain manufacturer's recommended clearances.

#### 5.1.2 Electrical Wiring

Install and connect electrical devices furnished by manufacturer but not specified to be factory mounted. Furnish copy of manufacturer's electrical connection diagram submittal to electrical contractor.

#### 5.1.3 Piping Connections

Install and connect devices furnished by manufacturer but not specified to be factory-mounted. Furnish copy of manufacturer's piping connection diagram submittal to piping contractor.

#### 5.1.4 Refrigerant Charging

Charge completed cooling system in accordance with manufacturer's refrigerant charging instructions.

#### 5.1.5 Field Quality Control

Start up cooling units in accordance with manufacturer's start-up instructions. Test controls and demonstrate compliance with requirements. These specifications describe requirements for a computer room environmental control system. The system shall be designed to maintain temperature and humidity conditions in the rooms containing electronic equipment.

The manufacturer shall design and furnish all equipment to be fully compatible with heat dissipation requirements.

#### 5.1.6 Supply and Drain Water Piping

Connect water supply and drains to air conditioning unit. Provide pitch and trap as manufacturer's instructions and local codes require.

### 5.2 Seismic IBC/OSHPD

#### 5.2.1 Vertiv™ Liebert® CRV

Install unit in accordance with manufacturer's installation instructions provided with seismic option. Firmly anchor maintaining manufacturer's recommended clearances. Mounting requirement details such as anchor brand, type, embedment depth, edge spacing, anchor-to-anchor spacing, concrete strength, special inspection, and attachment to non-building structures must be outlined and approved by the Engineer of Record for the projection or building. Wiring and piping connections must permit movement in three dimensions and isolate the unit from field connections. Electrical conduit shall be flexible, having at least one bend between the rigid connection at the unit cabinet and the connection to rigid conduit or foundation. The piping flexible connection or loop must be suitable for the operation pressure and temperature of the system. Furnish copy of manufacturer's piping connection diagram submittal to piping contractor.

## 5.2.2 Vertiv™ Liebert® MC

Install condenser in accordance with manufacturer's installation instructions provided with seismic option. Firmly anchor maintaining manufacturer's recommended clearances. Mounting requirement details such as anchor brand, type, embedment depth, edge spacing, anchor-to-anchor spacing, concrete strength, special inspection and attachment to non-building structures must be outlined and approved by the Engineer of Record for the projection or building. Wiring and piping connections must permit movement in three dimensions and isolate the unit from field connections. Electrical conduit shall be flexible, having at least one bend between the rigid connection at the unit cabinet and the connection to rigid conduit or foundation. The piping flexible connection or loop must be suitable for the operation pressure and temperature of the system. Furnish copy of manufacturer's piping connection diagram submittal to piping contractor.

## Appendix H: Submittal Drawings

Table H.1 Submittal Drawing Contents

Document Number	Title
<b>Standard and Optional Features</b>	
<b>Air Cooled 600 mm (24 inch) Models</b>	
DPN001904	Standard Features 600mm (24in.) Air Cooled Models
DPN001907	Optional Features 600mm (24in.) Air Cooled Models
<b>Air Cooled 300 mm (12 inch) Models</b>	
DPN002811	Standard Features 300mm (12in.) Air Cooled Models
DPN002812	Optional Features 300mm (12in.) Air Cooled Models
<b>Water/Glycol Cooled 600 mm (24 inch) Models</b>	
DPN001905	Standard Features 600mm (24in.) Water/Glycol Cooled Models
DPN001908	Optional Features 600mm (24in.) Water/Glycol Cooled Models
<b>Water/Glycol Cooled 300 mm (12 inch) Models</b>	
DPN003037	Standard Features 300mm (12in.) Water/Glycol Cooled Models
DPN003038	Optional Features 300mm (12in.) Water/Glycol Cooled Models
<b>Chilled Water Cooled 600 mm (24 inch) Models</b>	
DPN001906	Standard Features 600mm (24in.) Chilled Water Models
DPN001909	Optional Features 600mm (24in.) Chilled Water Models
<b>Chilled Water Cooled 300 mm (12 inch) Models</b>	
DPN002974	Standard Features 300mm (12in.) Chilled Water Models
DPN002973	Optional Features 300mm (12in.) Chilled Water Models
<b>Component Locations</b>	
DPN003738	Component Location, 600mm (24in.) Models
DPN003583	Component Location, 300mm (12in.) Air Cooled Models
DPN003585	Component Location, 300mm (12in.) Water Glycol Cooled Models
DPN003584	Component Location, 300mm (12in.) Chilled Water Models
<b>Planning Dimensions</b>	
DPN001791	Cabinet Dimensional Data, 600mm (24in.) Models
DPN002807	Cabinet Dimensional Data, 300mm (12in.) Models
<b>Piping Schematics and Connection Locations - Air Cooled Systems</b>	
DPN002858	General Arrangement Diagram 600mm (24in.) Air Cooled W/Liebert® MC Models
DPN002808	GENERAL Arrangements Diagram 300mm (12in.) Air Cooled W/Liebert® MC Models
DPN001792	Primary Connection Locations, CR020R and CR035R Air Cooled Models
DPN002813	Primary Connection Locations, 300mm (12in.) Air Cooled Models



**Table H.1 Submittal Drawing Contents (continued)**

Document Number	Title
DPN003954	Air Cooled Piping Schematic Condenser Above Indoor Unit
<b>Piping Schematics and Connection Locations - Water/Glycol Cooled Systems</b>	
DPN001985	General Arrangement Diagram 600mm Water/Glycol Cooled Models
DPN003039	General Arrangement Diagram 300mm (12inch) Water/Glycol Cooled Models
DPN001793	Primary Connection Locations CR020RW & CR035RW Water/Glycol Models
DPN003040	Connection Locations, 300 mm (12in.) Water/Glycol Cooled Models
<b>Piping Schematics and Connection Locations - Chilled Water Systems</b>	
DPN001986	General Arrangement Diagram 600mm (24in.) Chilled Water Models
DPN002976	General Arrangement Diagram, 300mm (12in.) Chilled Water Models
DPN001794	Primary Connection Locations, CR040 Chilled Water Models
DPN002815	Primary Connection Locations, 300mm (12in.) Chilled Water Models
<b>Electric Field Connections - 600 mm (24 inch) Models</b>	
DPN001884	Electrical Field Connections Descriptions, 600mm (24in.) Models
DPN002841	CANbus and Interlock Connections between 600mm (24in.) Unit and Liebert® MC Premium
DPN001911	Connection Paths IntelliSlot Cable for 600mm (24in.)
DPN003592	Unit-to-unit Network Connections, 600mm (24in.) Models
<b>Electrical Field Connections - 300 mm (12 inch) Models</b>	
DPN002810	Electrical Field Connections Descriptions 300mm (12in.) Model
DPN003036	CANbus and Interlock Connections between 300mm (12in.) Unit and Liebert® MC Premium
DPN003588	Low Voltage Field Wiring Routing, 300mm (12in.) All Models
DPN003589	Power Cable Routing Bottom Entry, 300mm (12in.) Air Cooled and Water/Glycol Cooled Models
DPN003590	Power Cable Routing Bottom Entry, 300mm (12in.) Chilled Water Models
DPN002814	IntelliSlot Cable Connection Paths, 300mm (12in.) Models
DPN003593	Unit-to-unit Network Connections, 300mm (12in.) Units
<b>Condenser Dimensional Data</b>	
DPN003436	Cabinet & Anchor Dimensional Data 1 Fan (MCS028, MCM040, MCL055)
DPN003437	Cabinet & Anchor Dimensional Data 2 Fan (MCS056, MCM080, MCL110) Dual Circuit
<b>Liebert® MC Piping</b>	
DPN002166	Piping Dimensional Data Single Circuit 1 Fan, 2 Fan, 3 Fan & 4 Fan Units
DPN002167	Piping Locations Single Circuit with Lee-Temp
<b>Liebert® MC Power Supply Wiring</b>	
DPN002169	Electrical Field Connections Premium Efficiency Control
DPN002374	Electrical Field Connections Premium Efficiency Control with Lee-Temp
<b>Liebert® MC Low Voltage Wiring</b>	
DPN002841	CANbus Communication Connection Between Liebert® CRV 600mm (24in.) and Liebert® MC

**Table H.1 Submittal Drawing Contents (continued)**

<b>Document Number</b>	<b>Title</b>
DPN003036	CANbus Communication Connection Between Liebert® CRV 300mm (12in.) and Liebert® MC
<b>Liebert® CRV Seismic Application</b>	
DPN002765	Seismic Data Application Assumptions and Requirements 600mm (24in.) Models
DPN003027	Seismic Data Application Assumptions and Requirements 300mm (12in.) Models
<b>Liebert® CRV Non-seismic Application</b>	
<b>600 mm (24 inch) Models</b>	
DPN003272	Dimensional Data 600mm (24in.) Rigid Floor Mount Bracket
DPN003273	Dimensional Data Floorstand 600mm (24in.) Models
<b>300 mm (12 inch) Models</b>	
DPN003694	Dimensional Data 300mm (12in.) Rigid Floor Mount Bracket
DPN003696	Floorstand Dimensional Data 300mm (12in.) Models
<b>Liebert® Drycooler Dimensions</b>	
DPN000274	Cabinet Anchor Dimensional & General Data 1-4 Fan Models
<b>Liebert® Drycooler Piping</b>	
DPN000275	Piping Connections
DPN003822	Piping Schematic Multiple Drycoolers & Cooling Units on Common Glycol Loop
<b>Liebert® Drycooler Electrical Connections</b>	
DPN000276	Electrical Field Connections for Fluid Temperature Control
<b>Liebert® Drycooler Pump Packages</b>	
DPN000329	Electrical & Piping Connection Data Pump Package
DPN000278	Piping Locations & Dimensional Data Single Pump Package
<b>Liebert® Drycooler Expansion Tank</b>	
DPN004183	General Arrangement Diagrams & Dimensional Data Expansion Tank for Glycol/Glycool™ Systems
<b>Liebert® Drycooler Compression Tank</b>	
DPN003898	General Arrangement Diagram & Dimensional Data ASME Compression Tank Kits Glycol/Glycool™ Systems

This page intentionally left blank

---

## STANDARD FEATURES

### 600mm (24in.) AIR COOLED MODELS

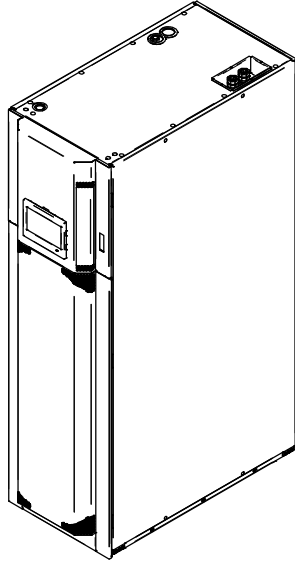

#### **STANDARD FEATURES** (Refer to specification sheet for options supplied)

**DX COOLING COIL** The evaporator coil has 7.25 ft<sup>2</sup> (0.674 m<sup>2</sup>) face area, 4 or 5 rows deep. It is constructed of copper tubes and hydrophilic coated aluminium fins. The hydrophilic coating provides superior water carryover resistance. Two stainless steel condensate drain pans are provided.

**REFRIGERATION SYSTEM** Single refrigeration circuit includes a liquid line filter drier, a refrigerant sight glass with moisture indicator, an adjustable externally equalized expansion valve, and a liquid line solenoid valve.

**COMPRESSOR** The compressor is an R-410A scroll-type with variable capacity operation from 20-100%; commonly known as a Digital Scroll. Compressor solenoid valve unloads the compressor to provide variable capacity operation. The compressor has a suction gas cooled motor, vibration isolators, internal thermal overloads, manual reset high pressure switch, RotoLock service valves, low pressure and high pressure transducer, crankcase heater, internal centrifugal oil pump, and an operating speed of 3500 RPM @ 60Hz (2900RPM @ 50Hz).

**FAN** The unit is equipped with two plug fans: direct driven centrifugal fans with backward curved blades and Electronically Commutated DC motors; commonly referred to as EC plug fans. The fan speed is variable and automatically regulated by the Liebert® iCOM control through all modes of operation. Each fan has a dedicated motor and speed controller which provides a level of redundancy. The fans push air through the coil and are located on the rear panel of the unit.

**SUPPLY AIR BAFFLE** A field adjustable, modular supply air baffle is located in the discharge air stream. It can be quickly and easily reconfigured to redirect airflow. The angles of the vanes have been optimized to effectively distribute air to heat generating equipment in a wide variety of applications.

**LIEBERT® iCOM™ CONTROL SYSTEM** The Liebert® CRV is controlled by the Liebert® iCOM™ Control System. The standard user interface is a 9 inch color touch screen which presents system information and allows all parameters to be viewed and adjusted. It features a 3-level password protection system. Unit-to-Unit communication with other Liebert® CRVs and two Liebert® IntelliSlot communication card housings are included as standard.



# LIEBERT® CRV

---

## STANDARD FEATURES

### 600mm (24in.) AIR COOLED MODELS

**2T RACK TEMPERATURE SENSORS** Consist of a vented case with two temperature probes. Three (3) 2T rack sensors are standard with each Liebert® CRV. Up to ten (10) 2T housings (20 temperature probes) can be connected to a Liebert® CRV. One (1) 2T housing and both sensor probes are to be attached to a rack the cooling unit is conditioning. The sensors provide real-time, direct feedback to the cooling unit to optimize the amount of cooling and airflow required; increasing energy efficiency and ensuring proper rack inlet air temperatures. The sensor data can also be reported to remote BMS and monitoring systems. The sensor network consists of one CAN wire leaving the cooling unit and connecting to a 2T sensor. Each remaining 2T sensor is connected to the previous sensor; often referred to as a daisy-chain configuration.

**REMOTE SHUTDOWN TERMINAL** Provides the customer with a location to remotely shut down the unit.

**COMMON ALARM CONTACT** Provides the customer with a set of normally open (n/o) contacts for remote indication of unit alarms.

**CABINET** The exterior steel panels are custom powder coated to protect against corrosion. The double wall constructed side panels separate the ½ inch, 2.0 lb/ft<sup>3</sup> insulation from the airstream. The unit is mounted on casters for quick installation and provided with levelling feet. The perforated inlet and outlet panels have 81% open area, and the rear door utilizes a Knürr rack style handle and hinges.

**SERVICE ACCESS** All service and maintenance is performed through the front and rear of the unit; including any component removal. No side access is required. All electrical and piping connections are made through the top and/or bottom of the unit. All units are provided with a Superior Service Access Panel to provide additional access.

**FILTER** The unit is equipped with two deep pleated 4 inch filters rated MERV8 (based on ASHRAE 52.2-2007), located within the cabinet, and accessible from the rear of the unit. A filter clog alarm is included.

**LOCKING DISCONNECT SWITCH** A moulded case circuit interrupter disrupts the flow of power to the unit. The electric panel high voltage compartment can only be accessed with the switch in the 'off' position. Conveniently located behind the Liebert® iCOM™ display door for quick access.

**65,000 AMP SHORT CIRCUIT CURRENT RATING (SCCR)** The electrical panel provides a 65k amp SCCR.

**DUAL-FLOAT CONDENSATE PUMP** It has a capacity of 6 GPM (22.7 l/min) at 30ft. (9m) head. Pump is complete with integral primary and secondary float switches, pump, motor assembly, and reservoir. The secondary float shall send a signal to the local alarm and shut down the unit upon high water condition.



# LIEBERT® CRV

## OPTIONAL FEATURES

### 600mm (24in.) AIR COOLED MODELS

#### OPTIONAL FEATURES (Refer to specification sheet for options supplied)

**HUMIDIFIER** A steam generating canister humidifier is factory-installed in the cooling unit and is operated by the Liebert® iCOM™ control system. It is complete with disposable cylinder, all supply and drain valves, steam distributor and electronic controls. The need to change the canister is indicated on the Liebert® iCOM™ display. The humidifier is designed to operate with water conductivity from 125-500 (50Hz) or 330-670 (60Hz) microS/cm. System automatically fills and drains as well as maintains the required water level based on conductivity. An air-gap within the humidifier assembly shall prevent backflow of the humidifier supply water. The humidifier is removable from the rear of the cabinet.

**ELECTRIC REHEAT** The electric reheat coils are low watt density, 304 stainless steel fin-tubular construction, protected by thermal safety switches and controlled in one stage.

**LOW NOISE PACKAGE** The Low Noise Package reduces the level of sound emitted from the compressor. The package consists of a 3/8 inch closed cell polymeric 4.5 – 8.5 lbs/ft<sup>3</sup> density compressor sound jacket that encloses the compressor. Additional 1/2 inch closed cell polymeric 3 - 8 lbs/ft<sup>3</sup> density sound deadening material is affixed to the underside of the Superior Service Access Panel located above the compressor and attached to the inner side of the compressor compartment panels that face the hot and cold aisles. All sound deadening material is non-shedding and located outside of the airstream.

**LIEBERT® INTELLISLOT SITELINK-E CARD (IS-485EXI)** Provides ground fault isolated connection to a Liebert® SiteLink-E for monitoring and management. Compatible with Liebert® SiteScan Web 4.0 or newer version.

**LIEBERT® INTELLISLOT UNITY CARD (LIEBERT® IS-UNITY-DP)** Provides ground fault isolated RS-485 Modbus, BACnet IP & Modbus IP network connectivity to Building Management Systems for unit monitoring and management. Also provides a ground fault isolated 10/100 baseT Ethernet connectivity for unit monitoring and management. The supported management interfaces include: SNMP for Network Management Systems, HTTP for web page viewing, SMTP for e-mail, and SMS for mobile messaging. This card can support dual IP and 485 protocols simultaneously.

**FILTER** The optional filters are two deep pleated 4 inch rated MERV11 following ASHRAE 52.2 (60-65% by ASHRAE 52.1), located within the cabinet and accessible from the rear of the unit. A filter clog alarm is included.

**REHEAT / HUMIDIFIER LOCKOUT** Includes the necessary relays to disable the reheat and humidifier from an external 24 volt signal.

**ONE (1) EXTRA COMMON ALARM CONTACT** Provides the customer with a total of two sets of normally open (n/o) contacts for remote indication of unit alarms.

**LIEBERT® LIQUI-TECT SENSOR** Is a solid state water sensor that has no moving parts and is hermetically sealed to keep out dust and dirt. When the sensor detects the presence of moisture the alarm system is activated.

---

## STANDARD FEATURES

### 300mm (12in.) AIR COOLED MODELS

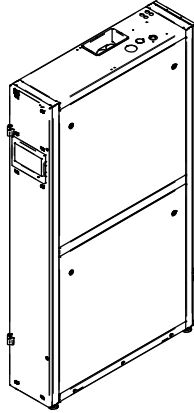

#### **STANDARD FEATURES** (Refer to specification sheet for options supplied)

**DX COOLING COIL** The evaporator coil has 6.46 ft<sup>2</sup> (0.60 m<sup>2</sup>) face area, 3 rows deep. It is constructed of copper tubes and hydrophilic coated aluminum fins. The hydrophilic coating provides superior water carryover resistance. A stainless steel condensate drain pan is provided.

**REFRIGERATION SYSTEM** Single refrigeration circuit includes a liquid line filter drier, a refrigerant sight glass with moisture indicator, an adjustable externally equalized expansion valve, and a liquid line solenoid valve.

**COMPRESSOR** The compressor is an R-410A scroll-type with variable capacity operation from 20-100%; commonly known as a Digital Scroll. Compressor solenoid valve unloads the compressor to provide variable capacity operation. The compressor has a suction gas cooled motor, vibration isolators, internal thermal overloads, manual reset high pressure switch, Rotolock service valves, low pressure and high pressure transducer, crankcase heater, internal centrifugal oil pump, sound jacket, and an operating speed of 3500 RPM @ 60Hz.

**FANS** The unit is equipped with five plug fans: direct driven centrifugal fans with backward curved blades and Electronically Commutated motors; commonly referred to as EC plug fans. The fan speed is variable and automatically regulated by the Liebert® iCOM™ control through all modes of operation. Each fan has a dedicated motor and integrated speed controller which provides a level of redundancy. The fans pull air through the coil and are located in the front of the unit.

**SUPPLY AIR BAFFLE** Field adjustable, modular supply air baffles are located in the discharge air stream. They can be quickly and easily reconfigured to redirect airflow.

**LIEBERT® iCOM™ CONTROL SYSTEM** The Liebert® CRV is controlled by the Liebert® iCOM™ Control System. The standard user interface is a 9 inch color touch screen which presents system information and allows all parameters to be viewed and adjusted. It features a 3-level password protection system. Unit-to-Unit communication with other Liebert® CRVs and two Liebert® IntelliSlot communication card housings are included as standard.

**2T RACK TEMPERATURE SENSORS** Consist of a vented case with two temperature probes. Three (3) 2T rack sensors are standard with each Liebert® CRV. Up to ten (10) 2T housings (20 temperature probes) can be connected to a Liebert® CRV300. One (1) 2T housing and both sensor probes are to be attached to a rack the cooling unit is conditioning. The sensors provide real-time, direct feedback to the cooling unit to optimize the amount of cooling and airflow required; increasing energy efficiency and ensuring proper rack inlet air temperatures. The sensor data can also be reported to remote BMS and monitoring systems. The sensor network consists of one CAN wire leaving the cooling unit and connecting to a 2T sensor. Each remaining 2T sensor is connected to the previous sensor; often referred to as a daisy-chain configuration.



# LIEBERT® CRV

---

## STANDARD FEATURES

### 300mm (12in.) AIR COOLED MODELS

**REMOTE SHUTDOWN TERMINAL** Provides the customer with a location to remotely shut down the unit.

**COMMON ALARM CONTACT** Provides the customer with a set of normally open (n/o) contacts for remote indication of unit alarms.

**CABINET** The exterior steel panels are custom powder coated to protect against corrosion. The unit is mounted on casters for quick installation and provided with leveling feet. The perforated inlet and outlet panels have 81% open area, the front door is hinged and the rear door is liftoff.

**SERVICE ACCESS** All service and maintenance is performed through the front and rear of the unit; including any component removal. No side access is required. All electrical and piping connections are made through the top and/or bottom of the unit.

**FILTER** The unit is equipped with two 1/2 inch filters rated MERV1 (based on ASHRAE 52.2-2007), located within the cabinet, and accessible from the rear of the unit. A filter clog alarm is included.

**LOCKING DISCONNECT SWITCH** A molded case circuit interrupter disrupts the flow of power to the unit. The electric panel high voltage compartment can only be accessed with the switch in the 'off' position located behind the rear door and filters for access.

**65,000 AMP SHORT CIRCUIT CURRENT RATING (SCCR)** The electrical panel provides a 65k amp SCCR.

**DUAL-FLOAT CONDENSATE PUMP** Capacity of 45 GPH (171l/hr) at 13ft (4m) head. Pump is complete with integral primary and secondary float switches, pump, motor assembly, and reservoir. The secondary float shall send a signal to the local alarm and shut down the unit upon high water condition.





# LIEBERT® CRV

---

## OPTIONAL FEATURES

### 300mm 12(in.) AIR COOLED MODELS

#### **OPTIONAL FEATURES** (Refer to specification sheet for options supplied)

**LIEBERT® INTELLISLOT SITELINK-E CARD (IS-485EXI)** Provides ground fault isolated connection to a Liebert® SiteLink-E for monitoring and management. Compatible with Liebert® SiteScan Web 4.0 or newer version.

**LIEBERT® INTELLISLOT UNITY CARD (IS-UNITY-DP)** Provides ground fault isolated RS-485 Modbus, BACnet IP & Modbus IP network connectivity to Building Management Systems for unit monitoring and management. Also, provides ground fault isolated 10/100 baseT Ethernet connectivity for unit monitoring and management. The supported management interfaces include: SNMP for Network Management Systems, HTTP for web page viewing, SMTP for email, and SMS for mobile messaging. This card can support dual IP and 485 protocols simultaneous.

**FILTER** The optional filters are two deep pleated 2 inch rated MERV8 (based on ASHRAE 52.2-2007) located within the cabinet and accessible from the rear of the unit. A filter clog alarm is included.

**ONE (1) EXTRA COMMON ALARM CONTACT** Provides the customer with a total of two sets of normally open (n/o) contacts for remote indication of unit alarms.

**LIEBERT® LIQUI-TECT SENSOR** Is a solid state water sensor that has no moving parts and is hermetically sealed to keep out dust and dirt. When the sensor detects the presence of moisture the alarm system is activated.

---

## STANDARD FEATURES

### 600mm (24in.) WATER/GLYCOL COOLED MODELS

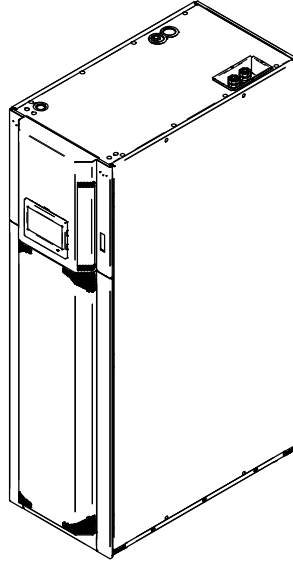

#### **STANDARD FEATURES** (Refer to specification sheet for options supplied)

**DX COOLING COIL** The evaporator coil has 7.25 ft<sup>2</sup> (0.674 m<sup>2</sup>) face area, 4 or 5 rows deep. It is constructed of copper tubes and hydrophilic coated aluminium fins. The hydrophilic coating provides superior water carryover resistance. Two stainless steel condensate drain pans are provided.

**REFRIGERATION SYSTEM** Single refrigeration circuit includes a liquid line filter drier, an adjustable externally equalized expansion valve, and a liquid line solenoid valve.

**COMPRESSOR** The compressor is an R-410A scroll-type with variable capacity operation from 20-100%; commonly known as a Digital Scroll. Compressor solenoid valve unloads the compressor to provide variable capacity operation. The compressor has a suction gas cooled motor, vibration isolators, internal thermal overloads, manual reset high pressure switch, RotoLock service valves, low pressure and high pressure transducer, crankcase heater, internal centrifugal oil pump, and an operating speed of 3500 RPM @ 60Hz (2900RPM @ 50Hz).

**FAN** The unit is equipped with two plug fans: direct driven centrifugal fans with backward curved blades and Electronically Commutated DC motors; commonly referred to as EC plug fans. The fan speed is variable and automatically regulated by the Liebert® iCOM™ control through all modes of operation. Each fan has a dedicated motor and speed controller which provides a level of redundancy. The fans push air through the coil and are located on the rear panel of the unit.

**WATER / GLYCOL CONDENSER** Is an efficient stainless steel brazed-plate condenser. Waterside threaded connections are provided for convenience. Proper filtration must be field supplied when used on open-loop water systems (cooling towers, etc). When operating on a closed-loop, to avoid undesired ice formation in the wintertime, it is advisable to use a water/glycol mixture.

**3-WAY MODULATING VALVE** A 3-way modulating valve controls the water/glycol flow passing through the brazed-plate condenser. The Liebert® iCOM™ control manages the valve actuator movement in order to maintain the desired condensing temperature for various entering water temperatures. The maximum differential pressure across the closed valve is 43.5 PSI (300 kPa). Maximum system pressure is 230 PSI (1586 kPa).



# LIEBERT® CRV

## STANDARD FEATURES

### 600mm (24in.) WATER/GLYCOL COOLED MODELS

**SUPPLY AIR BAFFLE** A field adjustable, modular supply air baffle is located in the discharge air stream. It can be quickly and easily reconfigured to redirect airflow. The angles of the vanes have been optimized to effectively distribute air to heat generating equipment in a wide variety of applications.

**LIEBERT® iCOM™ CONTROL SYSTEM** The Liebert® CRV is controlled by the Liebert® iCOM™ Control System. The standard user interface is a 9 inch color touch screen which presents system information and allows all parameters to be viewed and adjusted. It features a 3-level password protection system. Unit-to-Unit communication with other Liebert® CRVs and two Liebert® IntelliSlot communication card housings are included as standard.

**2T RACK TEMPERATURE SENSORS** Consist of a vented case with two temperature probes. Three (3) 2T rack sensors are standard with each Liebert® CRV. Up to ten (10) 2T housings (20 temperature probes) can be connected to a Liebert® CRV. One (1) 2T housing and both sensor probes are to be attached to a rack the cooling unit is conditioning. The sensors provide real-time, direct feedback to the cooling unit to optimize the amount of cooling and airflow required; increasing energy efficiency and ensuring proper rack inlet air temperatures. The sensor data can also be reported to remote BMS and monitoring systems. The sensor network consists of one CAN wire leaving the cooling unit and connecting to a 2T sensor. Each remaining 2T sensor is connected to the previous sensor; often referred to as a daisy-chain configuration.

**REMOTE SHUTDOWN TERMINAL** Provides the customer with a location to remotely shut down the unit.

**COMMON ALARM CONTACT** Provides the customer with a set of normally open (n/o) contacts for remote indication of unit alarms.

**CABINET** The exterior steel panels are custom powder coated to protect against corrosion. The double wall constructed side panels separate the ½ inch, 2.0 lb/ft<sup>3</sup> insulation from the airstream. The unit is mounted on casters for quick installation and provided with levelling feet. The perforated inlet and outlet panels have 81% open area, and the rear door utilizes a Knürr rack style handle and hinges.

**SERVICE ACCESS** All service and maintenance is performed through the front and rear of the unit; including any component removal. No side access is required. All electrical and piping connections are made through the top and/or bottom of the unit. All units are provided with a Superior Service Access Panel to provide additional access.

**FILTER** The unit is equipped with two deep pleated 4 inch filters rated MERV8 (based on ASHRAE 52.2-2007), located within the cabinet, and accessible from the rear of the unit. A filter clog alarm is included.

**LOCKING DISCONNECT SWITCH** A moulded case circuit interrupter disrupts the flow of power to the unit. The electric panel high voltage compartment can only be accessed with the switch in the 'off' position. Conveniently located behind the Liebert® iCOM™ display door for quick access.

**65,000 AMP SHORT CIRCUIT CURRENT RATING (SCCR)** The electrical panel provides a 65k amp SCCR.

**DUAL-FLOAT CONDENSATE PUMP** It has a capacity of 6 GPM (22.7 l/min) at 30ft. (9m) head. Pump is complete with integral primary and secondary float switches, pump, motor assembly, and reservoir. The secondary float shall send a signal to the local alarm and shut down the unit upon high water condition.



# LIEBERT® CRV

## OPTIONAL FEATURES

### 600mm (24in.) WATER/GLYCOL COOLED MODELS

#### OPTIONAL FEATURES (Refer to specification sheet for options supplied)

**HUMIDIFIER** A steam generating canister humidifier is factory-installed in the cooling unit and is operated by the Liebert® iCOM™ control system. It is complete with disposable cylinder, all supply and drain valves, steam distributor and electronic controls. The need to change the canister is indicated on the Liebert® iCOM™ display. The humidifier is designed to operate with water conductivity from 125-500 (50Hz) or 330-670 (60Hz) microS/cm. System automatically fills and drains as well as maintains the required water level based on conductivity. An air-gap within the humidifier assembly shall prevent backflow of the humidifier supply water. The humidifier is removable from the rear of the cabinet.

**ELECTRIC REHEAT** The electric reheat coils are low watt density, 304 stainless steel fin-tubular construction, protected by thermal safety switches and controlled in one stage.

**LOW NOISE PACKAGE** The Low Noise Package reduces the level of sound emitted from the compressor. The package consists of a 3/8 inch closed cell polymeric 4.5 – 8.5 lbs/ft<sup>3</sup> density compressor sound jacket that encloses the compressor. Additional 1/2 inch closed cell polymeric 3 - 8 lbs/ft<sup>3</sup> density sound deadening material is affixed to the underside of the Superior Service Access Panel located above the compressor and attached to the inner side of the compressor compartment panels that face the hot and cold aisles. All sound deadening material is non-shedding and located outside of the airstream.

**2-WAY MODULATING VALVE** A 2-way modulating valve controls the water/glycol flow passing through the brazed-plate condenser. The iCOM control manages the valve actuator movement in order to maintain the desired condensing temperature for various entering water flow rates and temperatures. The maximum differential pressure across the closed valve is 43.5 PSI (300 kPa). Maximum system pressure is 230 PSI (1586 kPa).

**LIEBERT® INTELLISLOT SITELINK-E CARD (LIEBERT® IS-485EXI)** Provides ground fault isolated connection to a Liebert® SiteLink-E for monitoring and management. Compatible with Liebert® SiteScan Web 4.0 or newer version.

**LIEBERT® INTELLISLOT UNITY CARD (LIEBERT® IS-UNITY-DP)** Provides ground fault isolated RS-485 Modbus, BACnet IP & Modbus IP network connectivity to Building Management Systems for unit monitoring and management. Also provides a ground fault isolated 10/100 baseT Ethernet connectivity for unit monitoring and management. The supported management interfaces include: SNMP for Network Management Systems, HTTP for web page viewing, SMTP for e-mail, and SMS for mobile messaging. This card can support dual IP and 485 protocols simultaneously.

**FILTER** The optional filters are two deep pleated 4 inch rated MERV11 following ASHRAE 52.2 (60-65% by ASHRAE 52.1), located within the cabinet and accessible from the rear of the unit. A filter clog alarm is included.

**REHEAT / HUMIDIFIER LOCKOUT** Includes the necessary relays to disable the reheat and humidifier from an external 24 volt signal.

**ONE (1) EXTRA COMMON ALARM CONTACT** Provides the customer with a total of two sets of normally open (n/o) contacts for remote indication of unit alarms.

**LIEBERT® LIQUI-TECT SENSOR** Is a solid state water sensor that has no moving parts and is hermetically sealed to keep out dust and dirt. When the sensor detects the presence of moisture the alarm system is activated.

---

## STANDARD FEATURES

### 300mm (12in.) WATER/GLYCOL COOLED MODELS

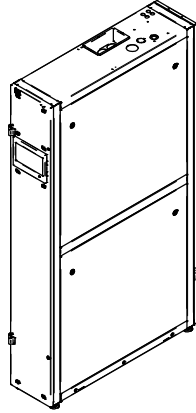

#### STANDARD FEATURES (Refer to specification sheet for options supplied)

**DX COOLING COIL** The evaporator coil has 6.46 ft<sup>2</sup> (0.60 m<sup>2</sup>) face area, 3 rows deep. It is constructed of copper tubes and hydrophilic coated aluminum fins. The hydrophilic coating provides superior water carryover resistance. A stainless steel condensate drain pan is provided.

**REFRIGERATION SYSTEM** Single refrigeration circuit includes a liquid line filter drier and an adjustable externally equalized expansion valve.

**COMPRESSOR** The compressor is an R-410A scroll-type with variable capacity operation from 20-100%; commonly known as a Digital Scroll. Compressor solenoid valve unloads the compressor to provide variable capacity operation. The compressor has a suction gas cooled motor, vibration isolators, internal thermal overloads, manual reset high pressure switch, Rotolock service valves, low pressure and high pressure transducer, crankcase heater, internal centrifugal oil pump, and an operating speed of 3500 RPM @ 60Hz.

**FANS** The unit is equipped with five plug fans: direct driven centrifugal fans with backward curved blades and Electronically Commutated motors; commonly referred to as EC plug fans. The fan speed is variable and automatically regulated by the Liebert® iCOM™ control through all modes of operation. Each fan has a dedicated motor and integrated speed controller which provides a level of redundancy. The fans pull air through the coil and are located in the front of the unit.

**SUPPLY AIR Baffle** Field adjustable, modular supply air baffles are located in the discharge air stream. They can be quickly and easily reconfigured to redirect airflow.

**LIEBERT® iCOM™ CONTROL SYSTEM** The Liebert® CRV is controlled by the Liebert® iCOM™ Control System. The standard user interface is a 9 inch color touch screen which presents system information and allows all parameters to be viewed and adjusted. It features a 3-level password protection system. Unit-to-Unit communication with other Liebert® CRVs and two Liebert® Intellislot communication card housings are included as standard.

**WATER / GLYCOL CONDENSER** Is an efficient stainless steel brazed-plate condenser. Waterside threaded connections are provided for convenience. Proper filtration must be field supplied when used on open-loop water systems (cooling towers, etc). When operating on a closed-loop, to avoid undesired ice formation in the wintertime, it is advisable to use a water/glycol mixture.

**3-WAY MODULATING VALVE** A 3-way modulating valve controls the water/glycol flow passing through the brazed-plate condenser. The Liebert® iCOM™ control manages the valve actuator movement in order to maintain the desired condensing temperature for various entering water temperatures. The maximum differential pressure across the closed valve is 43.5 PSI (300 kPa). Maximum system pressure is 230 PSI (1586 kPa).



# LIEBERT® CRV

## STANDARD FEATURES

### 300mm (12in.) WATER/GLYCOL COOLED MODELS

**2T RACK TEMPERATURE SENSORS** Consist of a vented case with two temperature probes. Three (3) 2T rack sensors are standard with each Liebert® CRV. Up to ten (10) 2T housings (20 temperature probes) can be connected to a Liebert® CRV300. One (1) 2T housing and both sensor probes are to be attached to a rack the cooling unit is conditioning. The sensors provide real-time, direct feedback to the cooling unit to optimize the amount of cooling and airflow required; increasing energy efficiency and ensuring proper rack inlet air temperatures. The sensor data can also be reported to remote BMS and monitoring systems. The sensor network consists of one CAN wire leaving the cooling unit and connecting to a 2T sensor. Each remaining 2T sensor is connected to the previous sensor; often referred to as a daisy-chain configuration.

**REMOTE SHUTDOWN TERMINAL** Provides the customer with a location to remotely shut down the unit.

**COMMON ALARM CONTACT** Provides the customer with a set of normally open (n/o) contacts for remote indication of unit alarms.

**CABINET** The exterior steel panels are custom powder coated to protect against corrosion. The unit is mounted on casters for quick installation and provided with leveling feet. The perforated inlet and outlet panels have 81% open area, the front door is hinged and the rear door is liftoff.

**SERVICE ACCESS** All service and maintenance is performed through the front and rear of the unit; including any component removal. No side access is required. Piping connection locations must be ordered top or bottom. Electrical connections are made through the top or bottom of the unit.

**FILTER** The unit is equipped with two 1/2 inch filters rated MERV1 (based on ASHRAE 52.2-2007), located within the cabinet, and accessible from the rear of the unit. A filter clog alarm is included.

**LOCKING DISCONNECT SWITCH** A molded case circuit interrupter disrupts the flow of power to the unit. The electric panel high voltage compartment can only be accessed with the switch in the 'off' position located behind the rear door and filters for access.

**65,000 AMP SHORT CIRCUIT CURRENT RATING (SCCR)** The electrical panel provides a 65k amp SCCR.

**DUAL-FLOAT CONDENSATE PUMP** Capacity of 45 GPH (171l/hr) at 13ft (4m) head. Pump is complete with integral primary and secondary float switches, pump, motor assembly, and reservoir. The secondary float shall send a signal to the local alarm and shut down the unit upon high water condition.



# LIEBERT® CRV

## OPTIONAL FEATURES

### 300mm (12in.) WATER/GLYCOL COOLED MODELS

**OPTIONAL FEATURES** (Refer to specification sheet for options supplied)

**LIEBERT® INTELLISLOT SITELINK-E CARD (IS-485EXI)** Provides ground fault isolated connection to a Liebert® SiteLink-E for monitoring and management. Compatible with Liebert® SiteScan Web 4.0 or newer version.

**LIEBERT® INTELLISLOT UNITY CARD (IS-UNITY-DP)** Provides ground fault isolated RS-485 Modbus, BACnet IP & Modbus IP network connectivity to Building Management Systems for unit monitoring and management. Also, provides ground fault isolated 10/100 baseT Ethernet connectivity for unit monitoring and management. The supported management interfaces include: SNMP for Network Management Systems, HTTP for web page viewing, SMTP for email, and SMS for mobile messaging. This card can support dual IP and 485 protocols simultaneous.

**FILTER** The optional filters are two deep pleated 2 inch rated MERV8 (based on ASHRAE 52.2-2007) located within the cabinet and accessible from the rear of the unit. A filter clog alarm is included.

**ONE (1) EXTRA COMMON ALARM CONTACT** Provides the customer with a total of two sets of normally open (n/o) contacts for remote indication of unit alarms.

**LIEBERT® LIQUI-TECT SENSOR** Is a solid state water sensor that has no moving parts and is hermetically sealed to keep out dust and dirt. When the sensor detects the presence of moisture the alarm system is activated.

**2-WAY MODULATING VALVE** A 2-way modulating valve controls the water/glycol flow passing through the brazed-plate condenser. The Liebert® iCOM™ control manages the valve actuator movement in order to maintain the desired condensing temperature for various entering water flow rates and temperatures. The maximum differential pressure across the closed valve is 43.5 PSI (300 kPa). Maximum system pressure is 230 PSI (1586 kPa).

---

## STANDARD FEATURES

### 600mm (24in.) CHILLED WATER MODELS

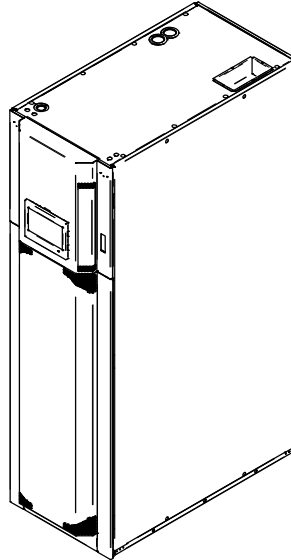

#### **STANDARD FEATURES** (Refer to specification sheet for options supplied)

**CW COOLING COIL** The evaporator coil has 7.25 ft<sup>2</sup> (0.674 m<sup>2</sup>) face area, 6 rows deep. It is constructed of copper tubes and hydrophilic coated aluminium fins. The hydrophilic coating provides superior water carryover resistance. Two stainless steel condensate drain pans are provided.

**CHILLED WATER SYSTEM** The water circuit includes a 3-way modulating valve. The Liebert® iCOM™ control positions the valve in response to room conditions. Cooling capacity will be controlled by bypassing chilled water around the coil.

**FAN** The unit is equipped with two plug fans: direct driven centrifugal fans with backward curved blades and Electronically Commutated DC motors; commonly referred to as EC plug fans. The fan speed is variable and automatically regulated by the iCOM control through all modes of operation. Each fan has a dedicated motor and speed controller which provides a level of redundancy. The fans push air through the coil and are located on the rear panel of the unit.

**3-WAY MODULATING VALVE** A 3-way modulating valve controls the chilled water flow passing through the cooling coil. The iCOM control manages the valve actuator movement in order to provide the desired amount of cooling for various entering water temperatures. Cooling capacity is regulated by bypassing chilled water around the coil. The maximum differential pressure across the closed valve is 200 PSI (1379 kPa). Maximum system pressure is 325 PSI (2241 kPa).

**SUPPLY AIR BAFFLE** A field adjustable, modular supply air baffle is located in the discharge air stream. It can be quickly and easily reconfigured to redirect airflow. The angles of the vanes have been optimized to effectively distribute air to heat generating equipment in a wide variety of applications.

**LIEBERT® iCOM™ CONTROL SYSTEM** The Liebert® CRV is controlled by the Liebert® iCOM™ Control System. The standard user interface is a 9 inch color touch screen which presents system information and allows all parameters to be viewed and adjusted. It features a 3-level password protection system. Unit-to-Unit communication with other Liebert® CRVs and two Liebert® IntelliSlot communication card housings are included as standard.





# LIEBERT® CRV

---

## STANDARD FEATURES

### 600mm (24in.) CHILLED WATER MODELS

**2T RACK TEMPERATURE SENSORS** Consist of a vented case with two temperature probes. Three (3) 2T rack sensors are standard with each Liebert® CRV. Up to ten (10) 2T housings (20 temperature probes) can be connected to a Liebert® CRV. One (1) 2T housing and both sensor probes are to be attached to a rack the cooling unit is conditioning. The sensors provide real-time, direct feedback to the cooling unit to optimize the amount of cooling and airflow required; increasing energy efficiency and ensuring proper rack inlet air temperatures. The sensor data can also be reported to remote BMS and monitoring systems. The sensor network consists of one CAN wire leaving the cooling unit and connecting to a 2T sensor. Each remaining 2T sensor is connected to the previous sensor; often referred to as a daisy-chain configuration.

**REMOTE SHUTDOWN TERMINAL** Provides the customer with a location to remotely shut down the unit.

**COMMON ALARM CONTACT** Provides the customer with a set of normally open (n/o) contacts for remote indication of unit alarms.

**CABINET** The exterior steel panels are custom powder coated to protect against corrosion. The double wall constructed side panels separate the ½ inch, 2.0 lb/ft<sup>3</sup> insulation from the airstream. The unit is mounted on casters for quick installation and provided with levelling feet. The perforated inlet and outlet panels have 81% open area, and the rear door utilizes a Knürr rack style handle and hinges.

**SERVICE ACCESS** All service and maintenance is performed through the front and rear of the unit; including any component removal. No side access is required. All electrical and piping connections are made through the top and/or bottom of the unit. All units are provided with a Superior Service Access Panel to provide additional access.

**FILTER** The unit is equipped with two deep pleated 4 inch filters rated MERV8 (based on ASHRAE 52.2-2007), located within the cabinet, and accessible from the rear of the unit. A filter clog alarm is included.

**LOCKING DISCONNECT SWITCH** A moulded case circuit interrupter disrupts the flow of power to the unit. The electric panel high voltage compartment can only be accessed with the switch in the 'off' position. Conveniently located behind the Liebert® iCOM™ display door for quick access.

**65,000 AMP SHORT CIRCUIT CURRENT RATING (SCCR)** The electrical panel provides a 65k amp SCCR.

**DUAL-FLOAT CONDENSATE PUMP** It has a capacity of 6 GPM (22.7 l/min) at 30ft. (9m) head. Pump is complete with integral primary and secondary float switches, pump, motor assembly, and reservoir. The secondary float shall send a signal to the local alarm and shut down the unit upon high water condition.



# LIEBERT® CRV

## OPTIONAL FEATURES

### 600mm (24in.) CHILLED WATER MODELS

**OPTIONAL FEATURES** (Refer to specification sheet for options supplied)

**HUMIDIFIER** A steam generating canister humidifier is factory-installed in the cooling unit and is operated by the Liebert® iCOM™ control system. It is complete with disposable cylinder, all supply and drain valves, steam distributor and electronic controls. The need to change the canister is indicated on the Liebert® iCOM™ display. The humidifier is designed to operate with water conductivity from 125-500 (50Hz) or 330-670 (60Hz) microS/cm. System automatically fills and drains as well as maintains the required water level based on conductivity. An air-gap within the humidifier assembly shall prevent backflow of the humidifier supply water. The humidifier is removable from the rear of the cabinet.

**ELECTRIC REHEAT** The electric reheat coils are low watt density, 304 stainless steel fin-tubular construction, protected by thermal safety switches and controlled in one stage.

**2-WAY MODULATING VALVE** A 2-way modulating valve controls the chilled water flow passing through the cooling coil. The Liebert® iCOM™ control manages the valve actuator movement in order to provide the desired amount of cooling for various entering water temperatures. Cooling capacity is regulated by varying the chilled water flow. The maximum differential pressure across the closed valve is 200 PSI (1379 kPa). Maximum system pressure is 325 PSI (2241 kPa).

**LIEBERT® INTELLISLOT SITELINK-E CARD (LIEBERT® IS-485EXI)** Provides ground fault isolated connection to a Liebert® SiteLink-E for monitoring and management. Compatible with Liebert® SiteScan Web 4.0 or newer version.

**LIEBERT® INTELLISLOT UNITY CARD (LIEBERT® IS-UNITY-DP)** Provides ground fault isolated RS-485 Modbus, BACnet IP & Modbus IP network connectivity to Building Management Systems for unit monitoring and management. Also provides a ground fault isolated 10/100 baseT Ethernet connectivity for unit monitoring and management. The supported management interfaces include: SNMP for Network Management Systems, HTTP for web page viewing, SMTP for e-mail, and SMS for mobile messaging. This card can support dual IP and 485 protocols simultaneously.

**FILTER** The optional filters are two deep pleated 4 inch rated MERV11 following ASHRAE 52.2 (60-65% by ASHRAE 52.1), located within the cabinet and accessible from the rear of the unit. A filter clog alarm is included.

**REHEAT / HUMIDIFIER LOCKOUT** Includes the necessary relays to disable the reheat and humidifier from an external 24 volt signal.

**ONE (1) EXTRA COMMON ALARM CONTACT** Provides the customer with a total of two sets of normally open (n/o) contacts for remote indication of unit alarms.

**LIEBERT® LIQUI-TECT SENSOR** Is a solid state water sensor that has no moving parts and is hermetically sealed to keep out dust and dirt. When the sensor detects the presence of moisture the alarm system is activated.

---

## STANDARD FEATURES

### 300mm (12in.) CHILLED WATER MODELS

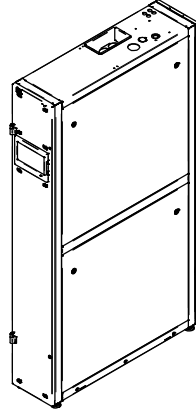

#### STANDARD FEATURES (Refer to specification sheet for options supplied)

**CW COOLING COIL** The 300 series evaporator coil is 3 rows deep with the 32kW model having 7.8ft<sup>2</sup> (0.72m<sup>2</sup>) of face area. It is constructed of copper tubes and hydrophilic coated aluminum fins. The hydrophilic coating provides superior water carryover resistance. A stainless steel condensate drain pan is provided.

**CHILLED WATER SYSTEM** The water circuit includes a characterized 3-way modulating ball valve. The Liebert® iCOM™ control positions the valve in response to room conditions. Cooling capacity will be controlled by bypassing chilled water around the coil. The maximum differential pressure across the closed valve is 200 PSI (1379 kPa). Maximum system pressure is 325 PSI (2241 kPa).

**FANS** The unit is equipped with six plug fans: direct driven centrifugal fans with backward curved blades and Electronically Commutated motors; commonly referred to as EC plug fans. The fan speed is variable and automatically regulated by the Liebert® iCOM™ control through all modes of operation. Each fan has a dedicated motor and integrated speed controller which provides a level of redundancy. The fans pull air through the coil and are located in the front of the unit.

**SUPPLY AIR BAFFLE** Field adjustable, modular supply air baffles are located in the discharge air stream. They can be quickly and easily reconfigured to redirect airflow.

**LIEBERT® iCOM™ CONTROL SYSTEM** The Liebert® CRV is controlled by the Liebert® iCOM™ Control System. The standard user interface is a 9 inch color touch screen which presents system information and allows all parameters to be viewed and adjusted. It features a 3-level password protection system. Unit-to-Unit communication with other Liebert® CRVs and two Liebert® IntelliSlot communication card housings are included as standard.

**2T RACK TEMPERATURE SENSORS** Consist of a vented case with two temperature probes. Three (3) 2T rack sensors are standard with each Liebert® CRV. Up to ten (10) 2T housings (20 temperature probes) can be connected to a Liebert® CRV300. One (1) 2T housing and both sensor probes are to be attached to a rack the cooling unit is conditioning. The sensors provide real-time, direct feedback to the cooling unit to optimize the amount of cooling and airflow required; increasing energy efficiency and ensuring proper rack inlet air temperatures. The sensor data can also be reported to remote BMS and monitoring systems. The sensor network consists of one CAN wire leaving the cooling unit and connecting to a 2T sensor. Each remaining 2T sensor is connected to the previous sensor; often referred to as a daisy-chain configuration.

**REMOTE SHUTDOWN TERMINAL** Provides the customer with a location to remotely shut down the unit.

**COMMON ALARM CONTACT** Provides the customer with a set of normally open (n/o) contacts for remote indication of unit alarms.



# LIEBERT® CRV

---

## STANDARD FEATURES

### 300mm (12in.) CHILLED WATER MODELS

**CABINET** The exterior steel panels are custom powder coated to protect against corrosion. The unit is mounted on casters for quick installation and provided with leveling feet. The perforated inlet and outlet panels have 81% open area, the front door is hinged and the rear door is liftoff.

**SERVICE ACCESS** All service and maintenance is performed through the front and rear of the unit; including any component removal. No side access is required. All electrical and piping connections are made through the top and/or bottom of the unit.

**FILTER** The unit is equipped with two 1/2 inch filters rated MERV1 (based on ASHRAE 52.2-2007), located within the cabinet, and accessible from the rear of the unit. A filter clog alarm is included.

**LOCKING DISCONNECT SWITCH** A molded case circuit interrupter disrupts the flow of power to the unit. The electric panel high voltage compartment can only be accessed with the switch in the 'off' position located behind the rear door and filters for access.

**SHORT CIRCUIT CURRENT RATING (SCCR)** The electrical panel provides a 65k amp SCCR for 208V & 460V units, and 5k amp SCCR rating for 120V units.

**DUAL-FLOAT CONDENSATE PUMP** Capacity of 45 GPH (171l/hr) at 13ft (4m) head. Pump is complete with integral primary and secondary float switches, pump, motor assembly, and reservoir. The secondary float shall send a signal to the local alarm and shut down the unit upon high water condition.



# LIEBERT® CRV

---

## OPTIONAL FEATURES

### 300mm (12in.) CHILLED WATER MODELS

**OPTIONAL FEATURES** (Refer to specification sheet for options supplied)

**2-WAY MODULATING VALVE** A 2-way modulating valve controls the chilled water flow passing through the cooling coil. The Liebert® iCOM™ control manages the valve actuator movement in order to provide the desired amount of cooling for various entering water temperatures. Cooling capacity is regulated by varying the chilled water flow. The maximum differential pressure across the closed valve is 200 PSI (1379 kPa). Maximum system pressure is 325 PSI (2241 kPa).

**LIEBERT® INTELLISLOT SITELINK-E CARD (IS-485EXI)** Provides ground fault isolated connection to a Liebert® SiteLink-E for monitoring and management. Compatible with Liebert® SiteScan Web 4.0 or newer version.

**LIEBERT® INTELLISLOT UNITY CARD (IS-UNITY-DP)** Provides ground fault isolated RS-485 Modbus, BACnet IP & Modbus IP network connectivity to Building Management Systems for unit monitoring and management. Also, provides ground fault isolated 10/100 baseT Ethernet connectivity for unit monitoring and management. The supported management interfaces include: SNMP for Network Management Systems, HTTP for web page viewing, SMTP for email, and SMS for mobile messaging. This card can support dual IP and 485 protocols simultaneous.

**FILTER** The optional filters are two deep pleated 2 inch rated MERV8 (based on ASHRAE 52.2-2007) located within the cabinet and accessible from the rear of the unit. A filter clog alarm is included.

**ONE (1) EXTRA COMMON ALARM CONTACT** Provides the customer with a total of two sets of normally open (n/o) contacts for remote indication of unit alarms.

**LIEBERT® LIQUI-TECT SENSOR** Is a solid state water sensor that has no moving parts and is hermetically sealed to keep out dust and dirt. When the sensor detects the presence of moisture the alarm system is activated.

## COMPONENT LOCATION DIAGRAM 600mm (24in.) MODELS

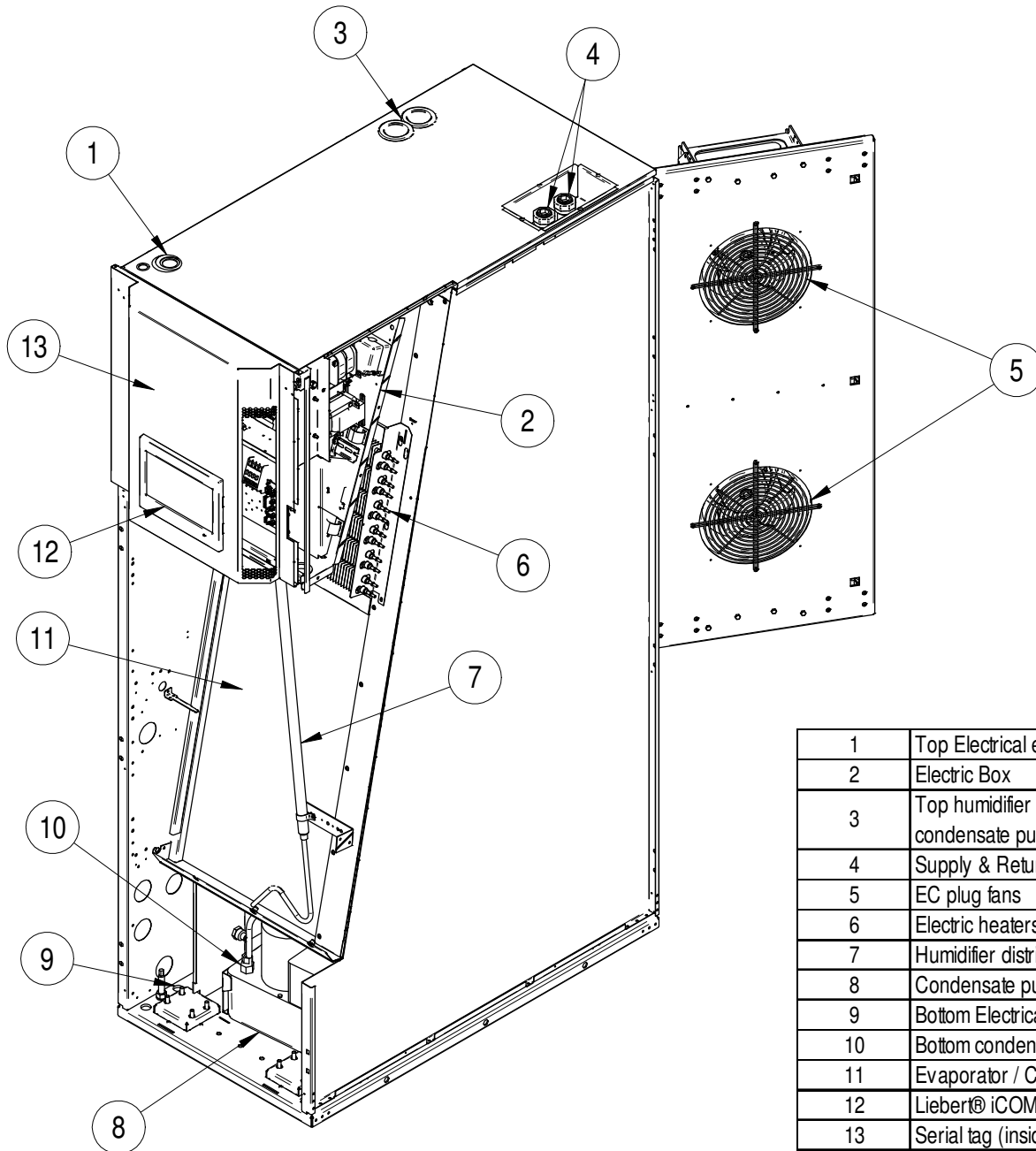

1	Top Electrical entrance
2	Electric Box
3	Top humidifier water supply, condensate pump drain
4	Supply & Return connections
5	EC plug fans
6	Electric heaters
7	Humidifier distributor
8	Condensate pump
9	Bottom Electrical entrance
10	Bottom condensate pump drain
11	Evaporator / CW coil
12	Liebert® iCOM™ Display
13	Serial tag (inside door)

## COMPONENT LOCATION

### 300mm (12in.) AIR COOLED MODELS

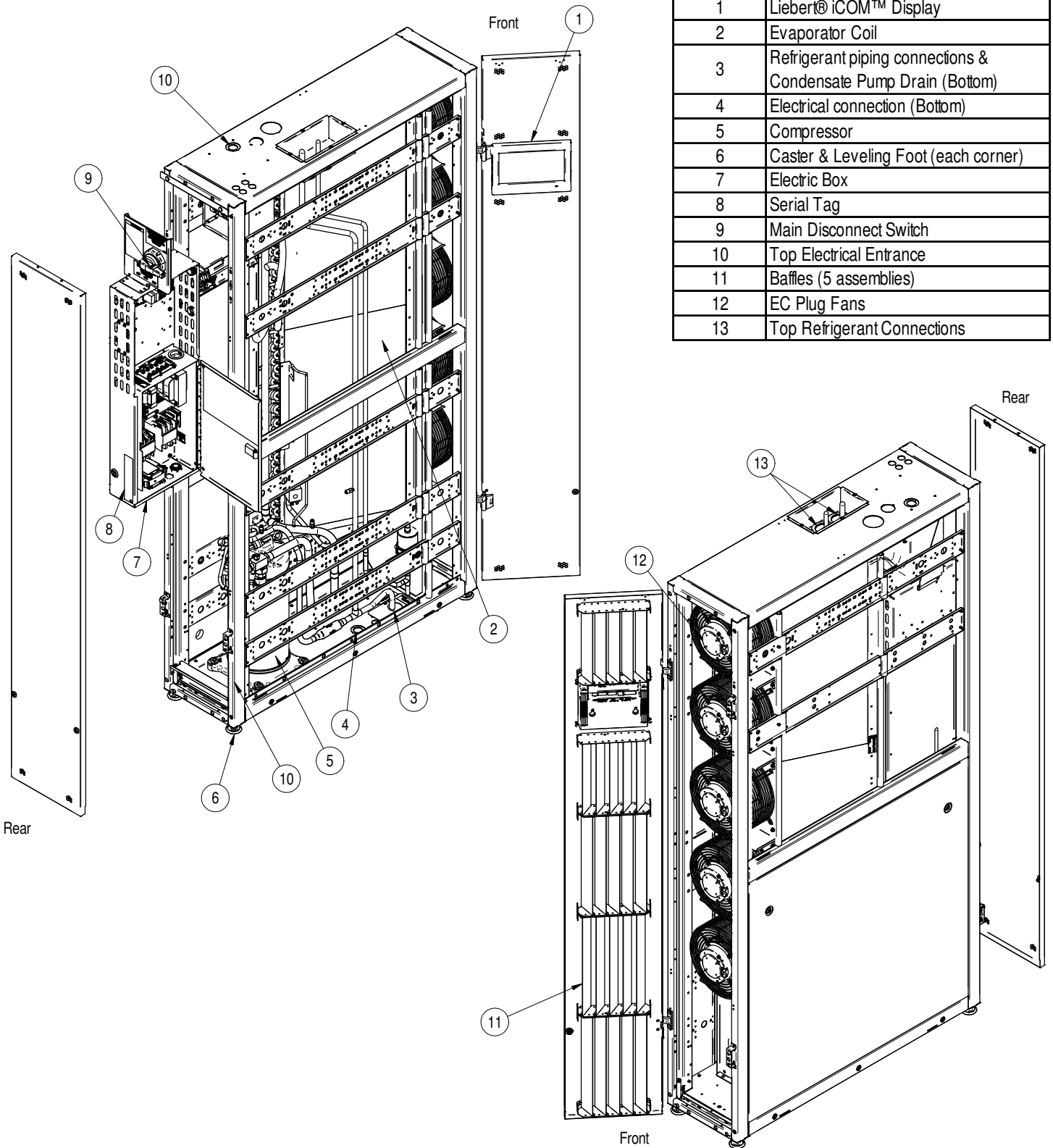

1	Liebert® iCOM™ Display
2	Evaporator Coil
3	Refrigerant piping connections & Condensate Pump Drain (Bottom)
4	Electrical connection (Bottom)
5	Compressor
6	Caster & Leveling Foot (each corner)
7	Electric Box
8	Serial Tag
9	Main Disconnect Switch
10	Top Electrical Entrance
11	Baffles (5 assemblies)
12	EC Plug Fans
13	Top Refrigerant Connections

## COMPONENT LOCATION

### 300mm (12in.) WATER GLYCOL COOLED MODELS

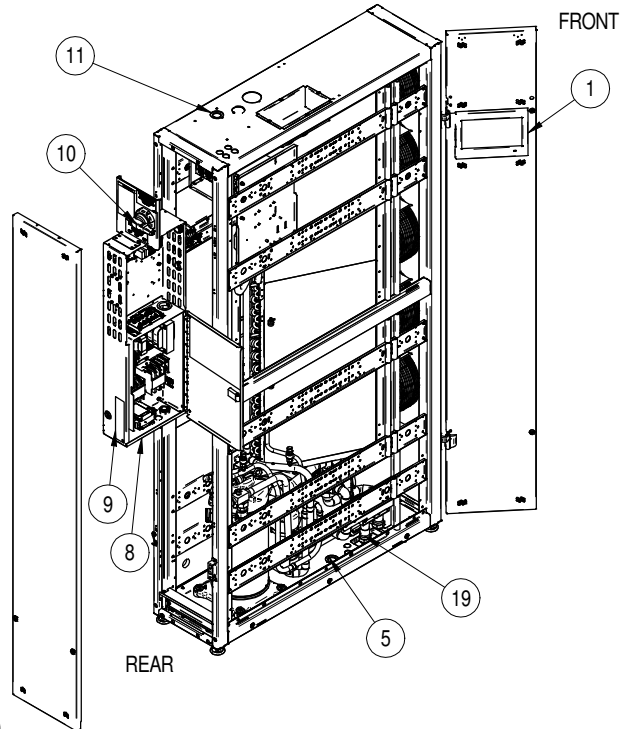
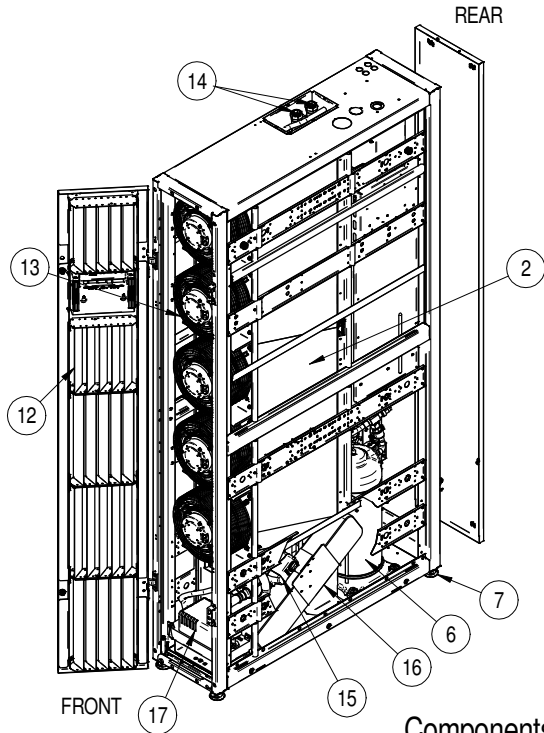
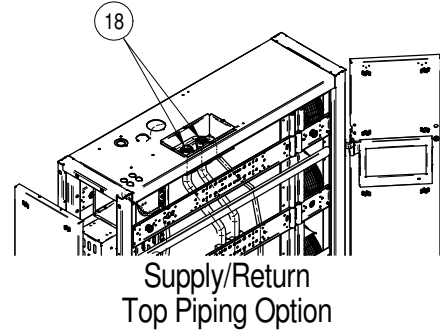
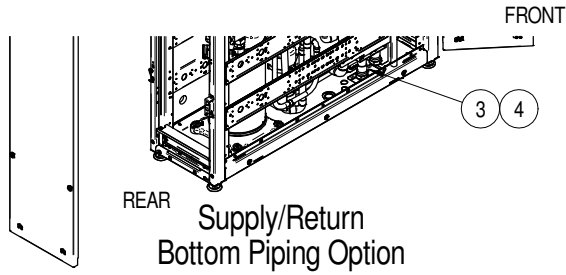

Components common to  
Top and Bottom Piping Options

1	Liebert® iCOM™ Display	11	Top Electrical Entrance
2	Evaporator Coil	12	Baffles (5 assemblies)
3	Supply/Return Connections (Bottom Piping Option)	13	EC Plug Fans (5 typ.)
4	Knockouts for Supply/Return (Bottom Piping Option)	14	Condensate Pump Drain Top Connection
5	Bottom Electrical Entrance	15	Control Valve
6	Compressor	16	Heat Exchanger (Plate)
7	Caster & Leveling Foot (Each Corner)	17	Condensate Pump
8	Electric Box	18	Supply/Return Connections (Top Piping Option)
9	Serial Tag	19	Condensate Pump Drain Bottom Connection
10	Main Disconnect Switch		



## COMPONENT LOCATION 30mm (12in.) CHILLED WATER MODELS

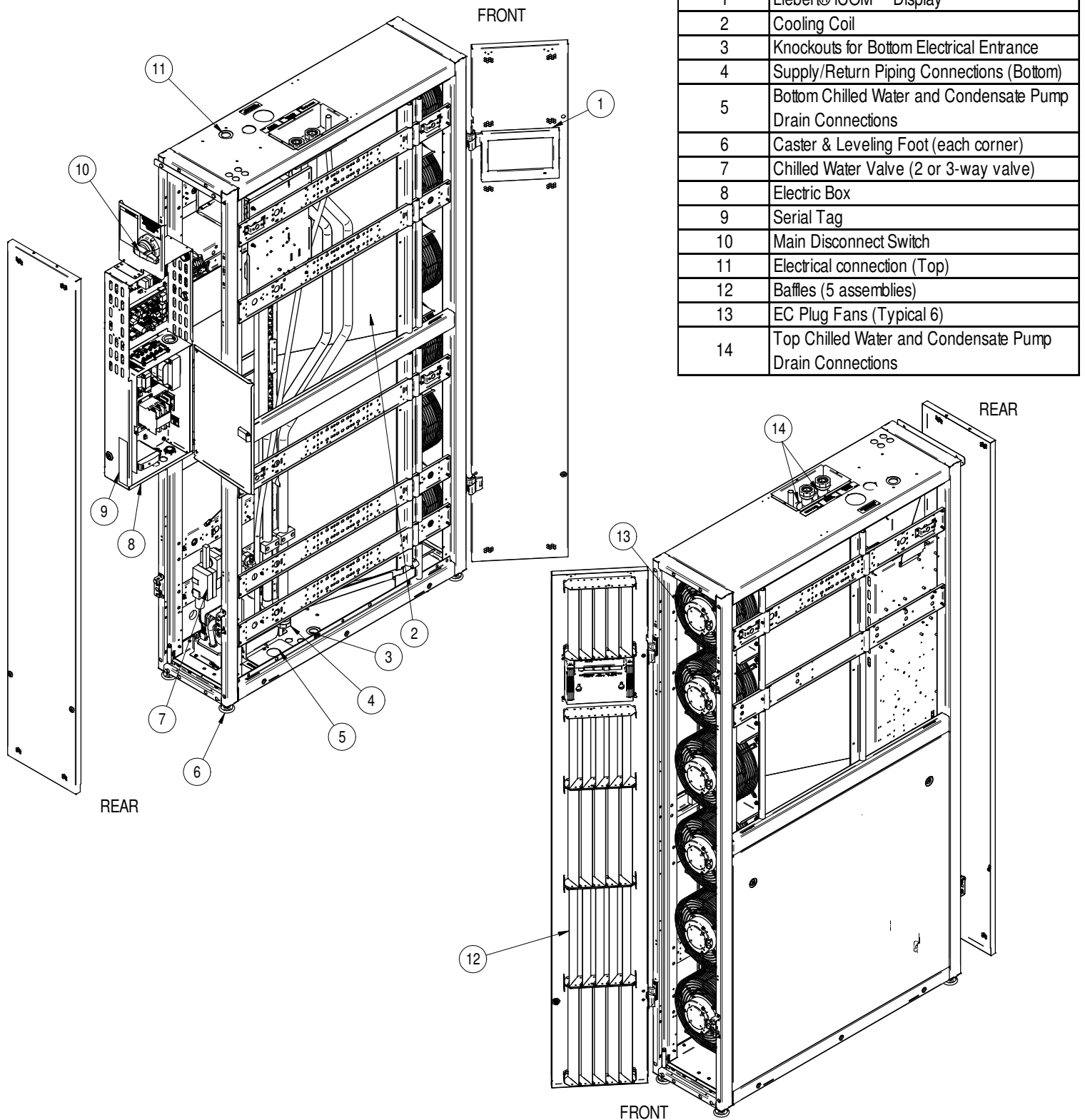

## CABINET DIMENSIONAL DATA 600mm (24in.) MODELS

ACCESS REQUIRED TO SERVICE THE LIEBERT® CRV UNIT WITHIN THE ROW  
REAR SERVICE AREA IS S+B OR S+A WHEN B IS NOT AVAILABLE

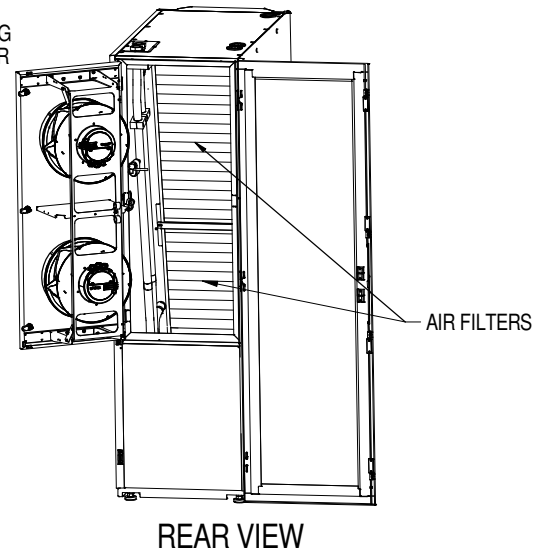
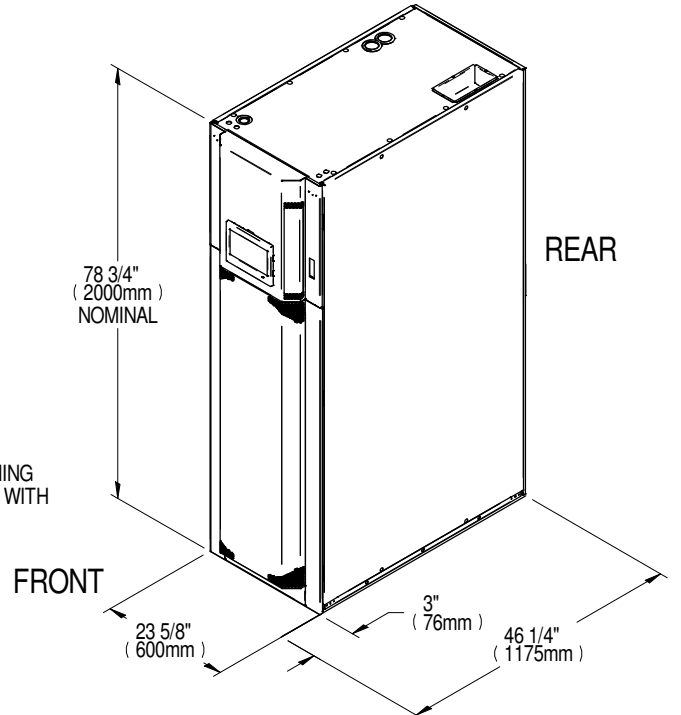
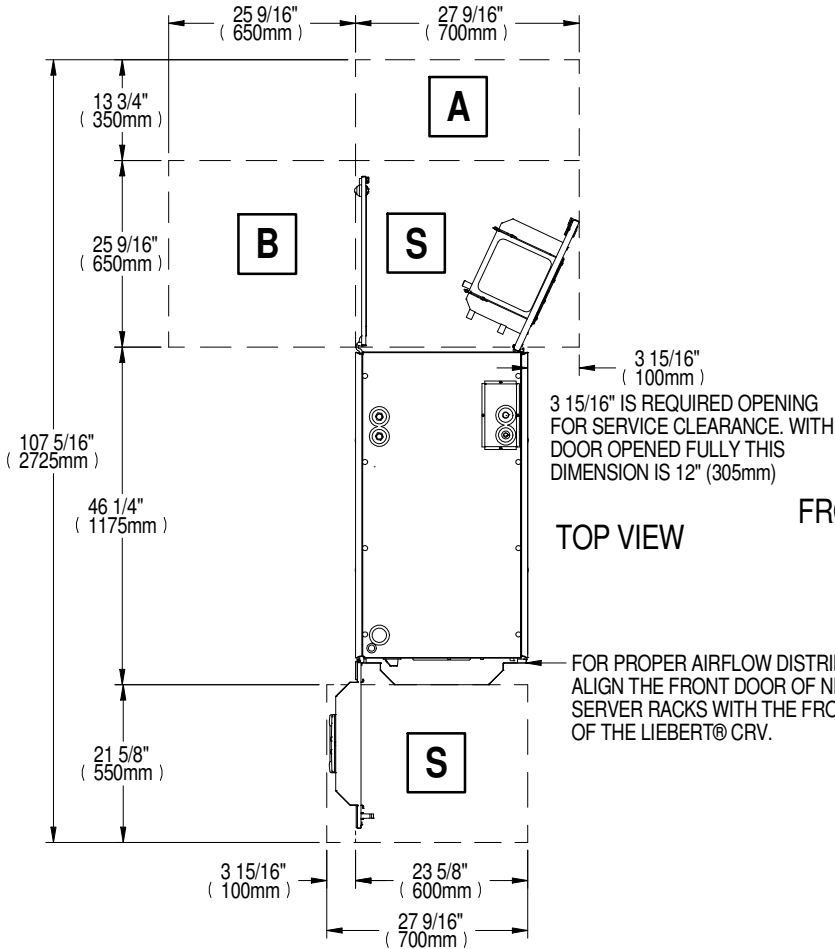

ACCESS REQUIRED FOR INSTALLATION OF THE LIEBERT® CRV UNIT WITHIN THE ROW.

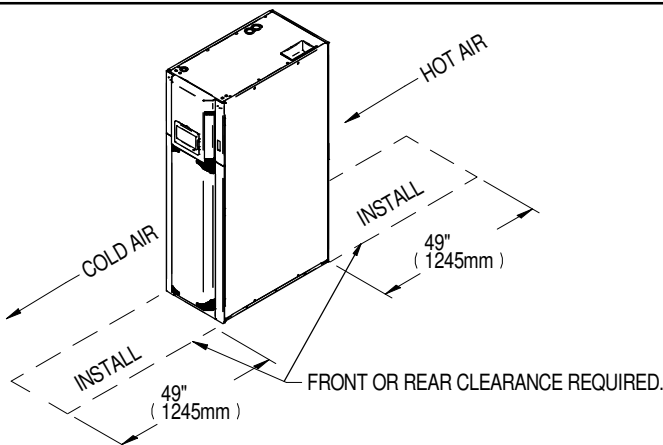

DRY WEIGHT ±5% - Lbs (kg)			
MODEL	AIR COOLED	WATER/GLYCOL	CHILLED WATER
CR020R	739 (335)	772 (350)	N/A
CR035R	805 (365)	849 (385)	
CR040R	N/A	N/A	728 (330)

## CABINET DIMENSIONAL DATA 300mm (12in.) MODELS

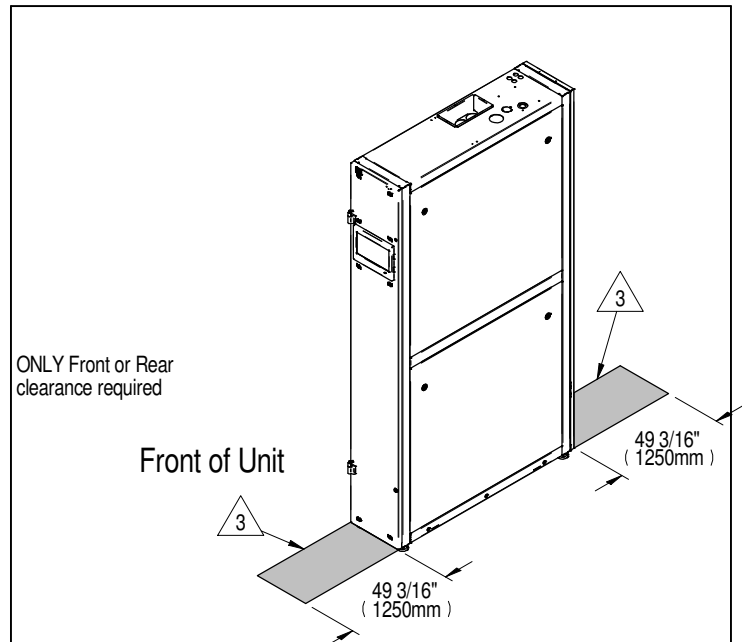
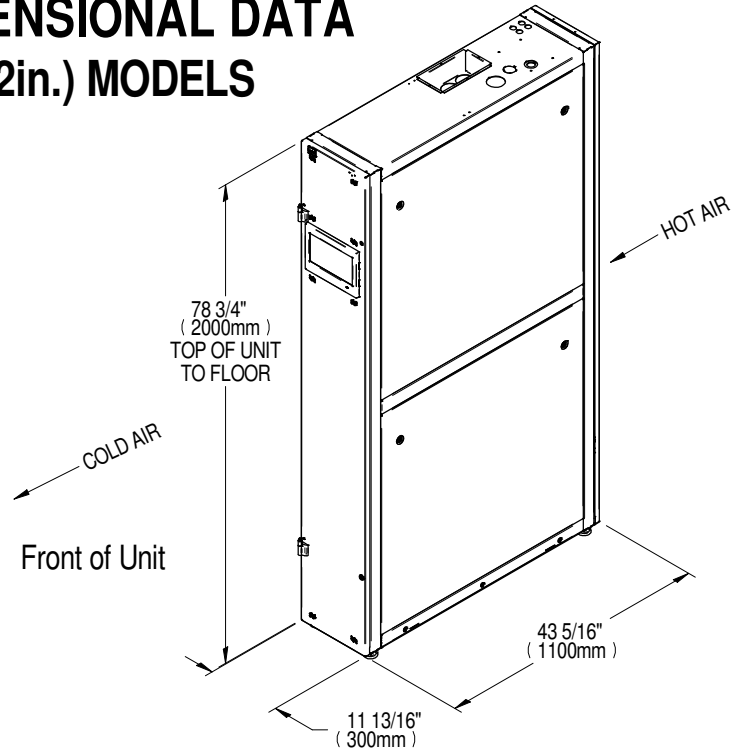
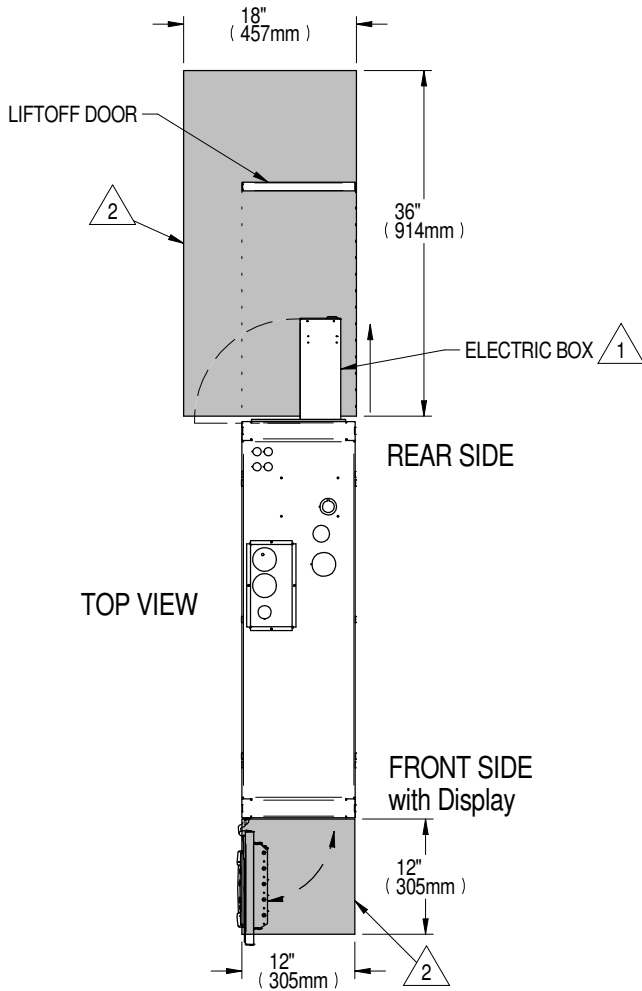

**NOTES:**

1. ELECTRIC BOX IS IN REAR OF UNIT (SHOWN FULLY EXTENDED). FOR SERVICE ACCESS TO ELECTRIC BOX REMOVE REAR DOOR. SLIDE ELECTRIC BOX REARWARD IN DIRECTION OF ARROW. ELECTRIC BOX DOOR SWINGS OPEN AS SHOWN. REAR EDGE OF UNIT MUST BE FLUSH WITH ADJACENT CABINET WITH REAR DOOR INSTALLED.
2. SHADED AREAS INDICATE ACCESS REQUIRED TO SERVICE THE ELECTRICAL AND MECHANICAL COMPONENTS OF THE UNIT BETWEEN EXISTING RACKS WITHIN THE ROW.
3. SHADED AREAS INDICATE ACCESS REQUIRED TO INSTALL THE UNIT BETWEEN EXISTING RACKS WITHIN THE ROW.

Cooling System	Dry Weight, +/- 5% lbs (kg)
AIR	507 (230)
WTR/GLY	545 (247)
CW	418 (190)

## GENERAL ARRANGEMENT DIAGRAM 600mm (24in.) AIR COOLED W/ LIEBERT® MC MODELS

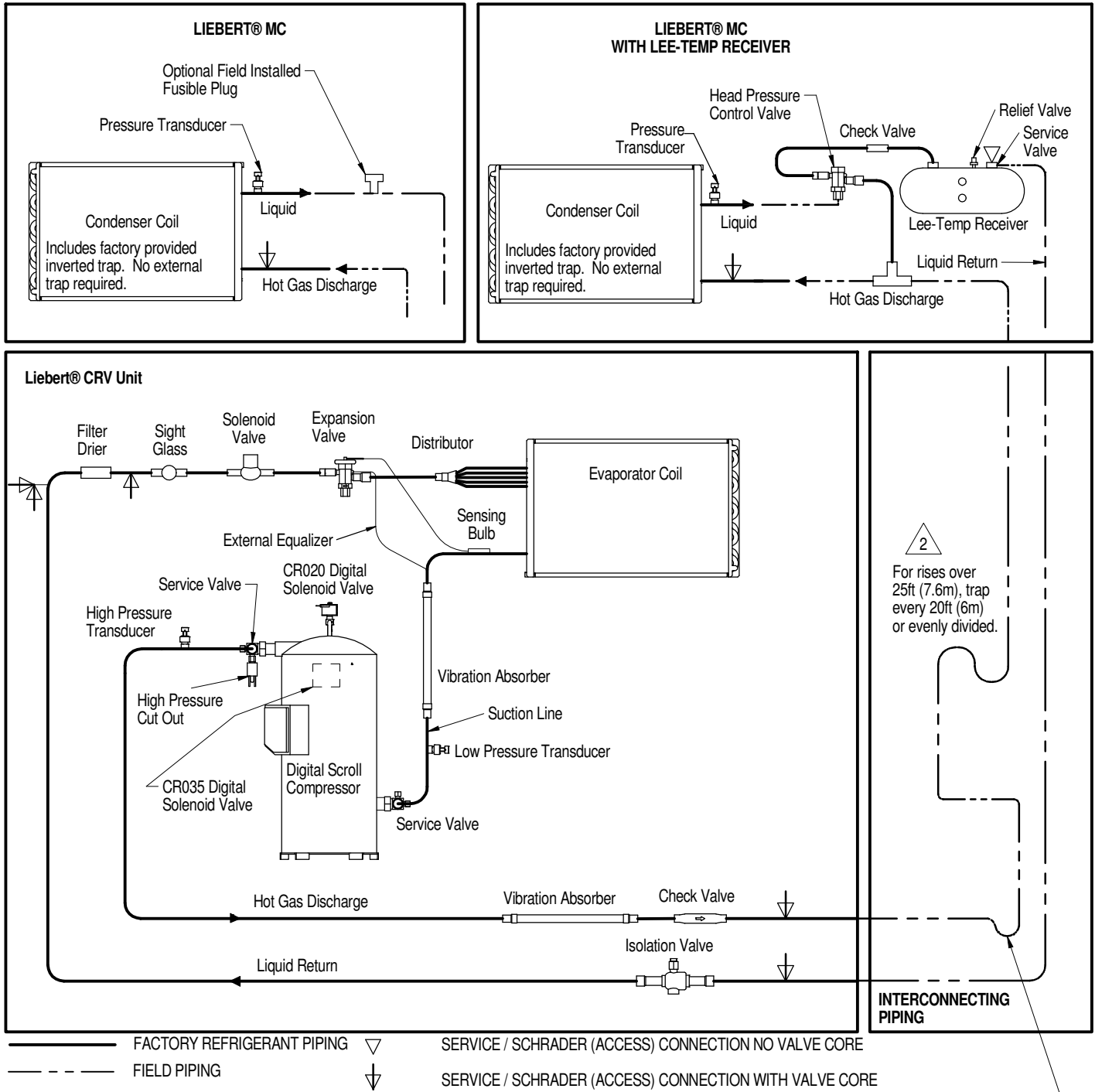

**Notes:**

1. Schematic representation shown. Do not use for specific connection locations.
2. Components are not supplied by Vertiv™, but are required for proper circuit operation and maintenance. Liebert® CRV has an internal trap at the base of the unit. For field piping the discharge line vertical rise starts at the base of the unit and not the top of the unit.
3. Do not isolate any refrigerant circuit from over pressurization protection.
4. Traps must be installed and horizontal lines pitched to ensure proper oil return and to reduce liquid floodback to compressor. Pitch horizontal hot gas piping at a minimum of 1/2" per 10 feet (42mm per 10m) so that gravity will aid in moving oil in the direction of the refrigeration flow.

## GENERAL ARRANGEMENT DIAGRAM 300mm (12in.) AIR COOLED W/ LIEBERT® MC MODELS

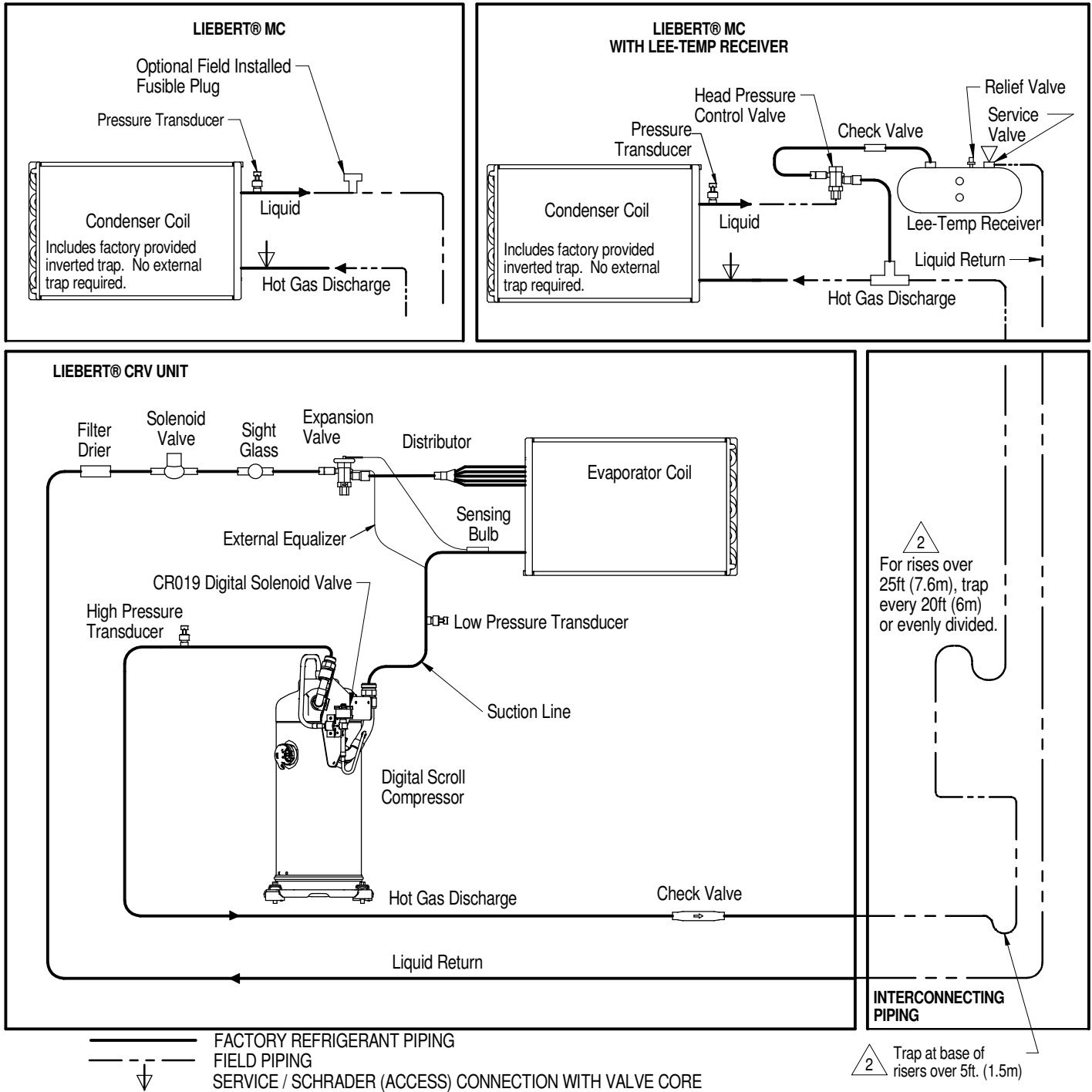

**Notes:**

1. Schematic representation shown. Do not use for specific connection locations.

2. Components are not supplied by Vertiv™, but are required for proper circuit operation and maintenance. Liebert® CRV has an internal trap at the base of the unit. For field piping, the discharge line vertical rise starts at the base of the unit and not at the top.

3. Do not isolate any refrigerant circuit from over pressurization protection.

4. Traps must be installed and horizontal lines pitched to ensure proper oil return and to reduce liquid floodback to compressor. Pitch horizontal hot gas piping at a minimum of 1/2" per 10 feet (42mm per 10m) so that gravity will aid in moving oil in the direction of the refrigeration flow.

## PRIMARY CONNECTION LOCATIONS CR020RA & CR035RA AIR COOLED MODELS

**Notes:**

- Piping and electrical connections available at the top and bottom of unit.  
Attention: Air cooled systems may require additional oil to be added in the field in order to allow for sufficient compressor lubrication. Please see the user manual for details.

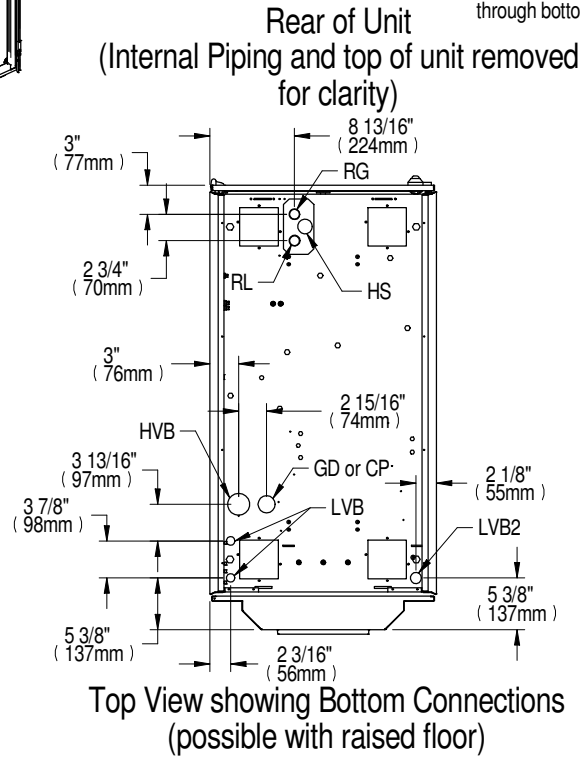
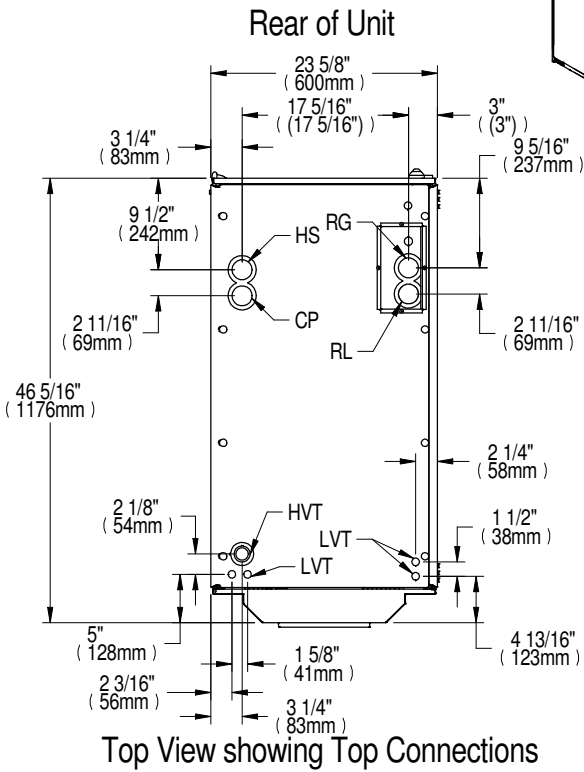
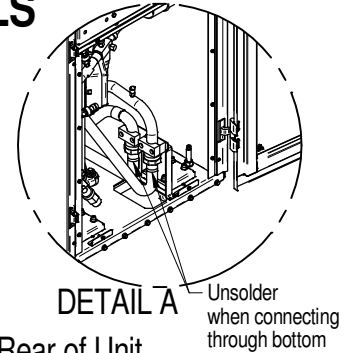
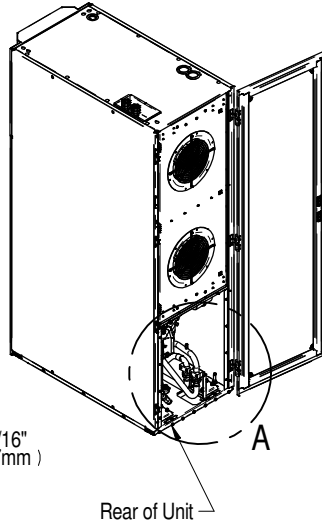

Unit Connections		CR20RA	CR35RA
RL	Refrigerant Liquid Line Inlet	1/2" O.D. Cu	5/8" O.D. Cu
RG	Refrigerant Gas Line Outlet	5/8" O.D. Cu	7/8" O.D. Cu
GD	Gravity Coil Pan Drain	1" MPT	
CP	Condensate Pump	1/2" NPT Female	
HS	Humidifier Supply	1/2" NPT Female (top connection) 1/4" Compression Fitting (bottom connection)	
HVT	High Voltage	Combination Knockout Hole Diameter 35mm (1-3/8"), 45mm (1-3/4") and 64mm (2-1/2")	
HVB	High Voltage Bottom Entrance (feed through bottom of unit)	Hole Diameter 64mm (2-1/2")	
LVT	Low Voltage	Hole Diameter 22mm (7/8") 2 places	
LVB	Low Voltage Bottom Entrance	Hole Diameter 28mm (1-1/8") 2 places	
LVB2	(feed through bottom of unit)	Hole Diameter 45mm (1-3/4") 1 place	

## PRIMARY CONNECTION LOCATIONS 300mm (12in.) AIR COOLED MODELS

PIPING AND ELECTRICAL CONNECTIONS AVAILABLE AT THE TOP AND BOTTOM OF UNIT.

ATTENTION, AIR COOLED SYSTEMS MAY REQUIRE ADDITIONAL OIL TO BE ADDED IN THE FIELD IN ORDER TO ALLOW FOR SUFFICIENT COMPRESSOR LUBRICATION. SEE UNIT USER MANUAL FOR DETAILS.

Front of Unit  
(Internal Piping and top of unit removed for clarity)

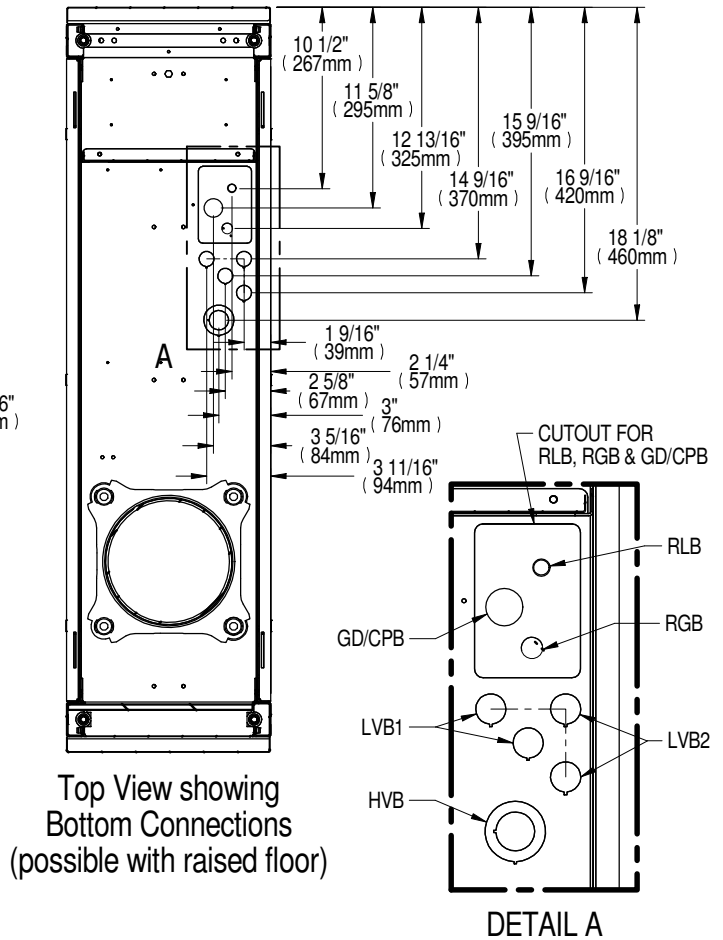
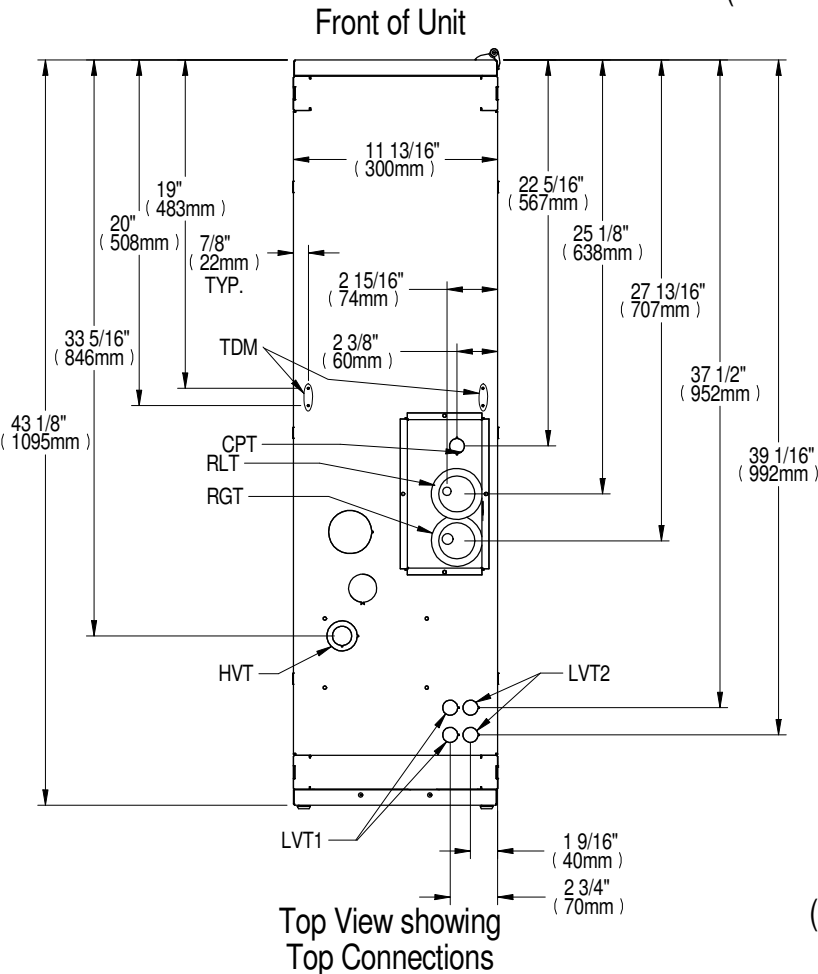

Unit Top Connections		CR019 (60Hz)	Unit Bottom Connections		CR019 (60Hz)
RLT	Refrigerant Liquid Line Inlet	1/2" O.D. Cu	RLB	Refrigerant Liquid Line Inlet	1/2" O.D. Cu
RGT	Refrigerant Gas Line Outlet	5/8" O.D. Cu	RGB	Refrigerant Gas Line Outlet	5/8" O.D. Cu
CPT	Condensate Pump	Knockout Hole Ø1-3/8" (35mm)	GD	Gravity Coil Pan Drain	Knockout Hole Diameter 1-3/4" (44mm)
HVT	High Voltage Top Connection	Combination Knockout Ø1-1/8" (29mm) & Ø1-3/4" (44mm)	CPB	Condensate Pump	
LVT1	Low Voltage (Twisted Pair)	Knockout Hole Ø7/8" (22mm) 2 places	HVB	High Voltage Bottom Entrance (feed through the base of the unit)	Combination Knockout 1-1/8" (29mm) & 1-3/4"
LVT2	Low Voltage (Shielded Cable)	Knockout Hole Ø7/8" (22mm) 2 places	LVB1	Low Voltage (Twisted Pair)	Knockout Hole Ø7/8" (22mm) 2 places
TDM	Tie Down (Top) Mounting	Hole Ø1/8" (3mm) 4 places	LVB2	Low Voltage (Shielded Cable)	

## AIR COOLED PIPING SCHEMATIC CONDENSER ABOVE INDOOR UNIT

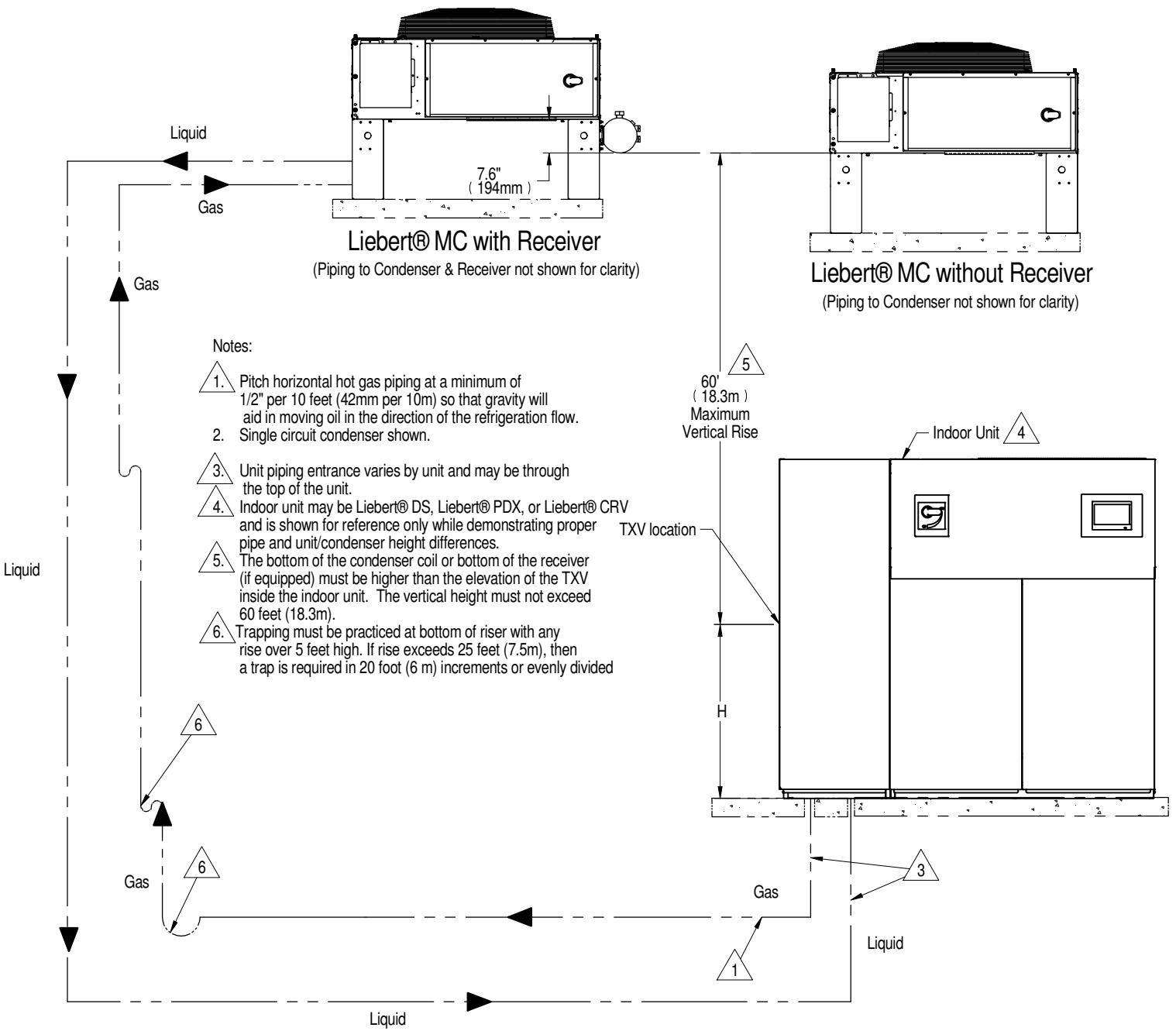

- Notes:
1. Pitch horizontal hot gas piping at a minimum of 1/2" per 10 feet (42mm per 10m) so that gravity will aid in moving oil in the direction of the refrigeration flow. Single circuit condenser shown.
  2. Unit piping entrance varies by unit and may be through the top of the unit.
  3. Indoor unit may be Liebert® DS, Liebert® PDX, or Liebert® CRV and is shown for reference only while demonstrating proper pipe and unit/condenser height differences.
  4. The bottom of the condenser coil or bottom of the receiver (if equipped) must be higher than the elevation of the TXV inside the indoor unit. The vertical height must not exceed 60 feet (18.3m).
  5. Trapping must be practiced at bottom of riser with any rise over 5 feet high. If rise exceeds 25 feet (7.5m), then a trap is required in 20 foot (6 m) increments or evenly divided

Internal TXV Height	H in. (mm)
Liebert® PDX Downflow	44 (1118)
Liebert® PDX Upflow	20 (508)
Liebert® DS	43 (1092)
Liebert® CRV - CR019	45 (1143)
Liebert® CRV - CR020/CR035	27 (686)



## AIR COOLED PIPING SCHEMATIC CONDENSER AND INDOOR UNIT AT SAME LEVEL

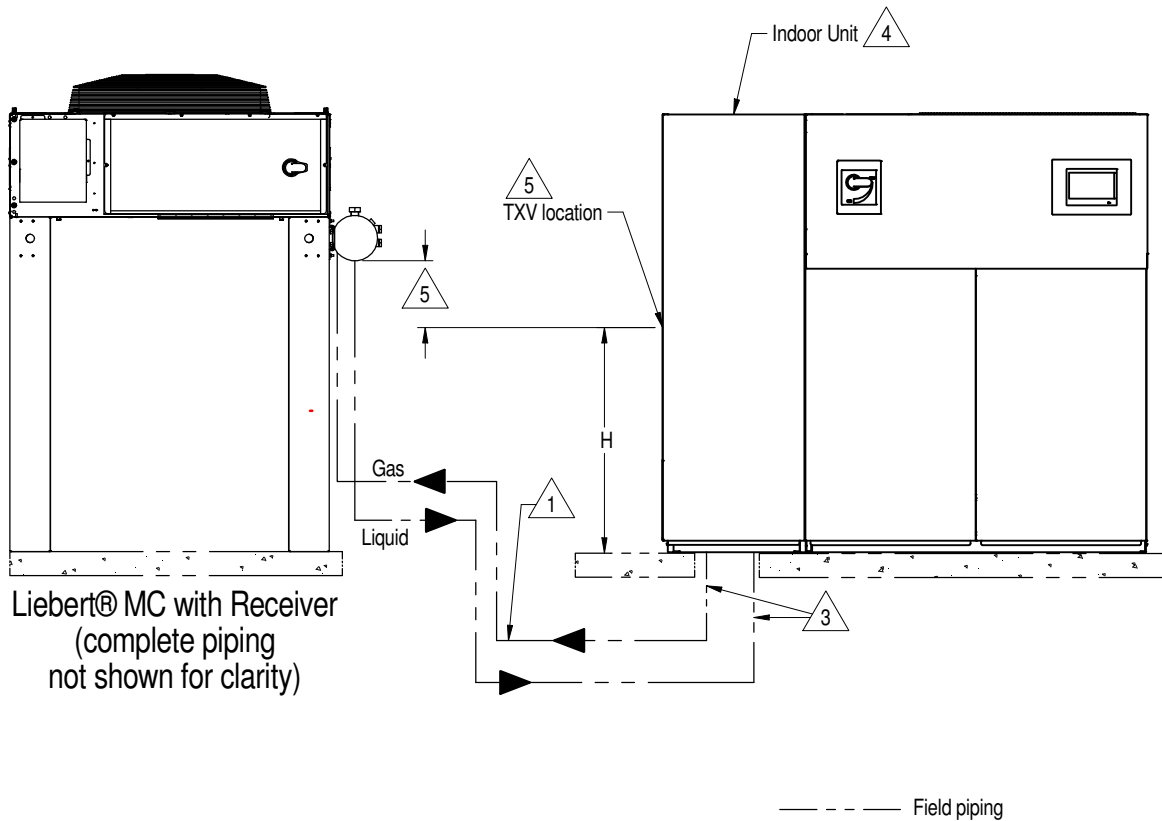

Liebert® MC with Receiver  
(complete piping  
not shown for clarity)

Notes:

1. Pitch horizontal hot gas piping at a minimum of 1/2" per 10 feet (42mm per 10m) so that gravity will aid in moving oil in the direction of the refrigeration flow.
2. Single circuit condenser shown.
3. Unit piping entrance varies by unit and may be through the top of the unit.
4. Indoor unit may be Liebert® DS, Liebert® PDX, or Liebert® CRV and is shown for reference only.
5. The bottom of the receiver must be higher than the elevation of the TXV inside the indoor unit, otherwise extended legs or a field piped subcooler needs to be utilized. Contact your Vertiv sales representative for additional information.

Internal TXV Height	H in. (mm)
Liebert® PDX Downflow	44 (1118)
Liebert® PDX Upflow	20 (508)
Liebert® DS	43 (1092)
Liebert® CRV - CR019	45 (1143)
Liebert® CRV - CR020/CR035	27 (686)

## AIR COOLED PIPING SCHEMATIC CONDENSER AND INDOOR UNIT AT SAME LEVEL

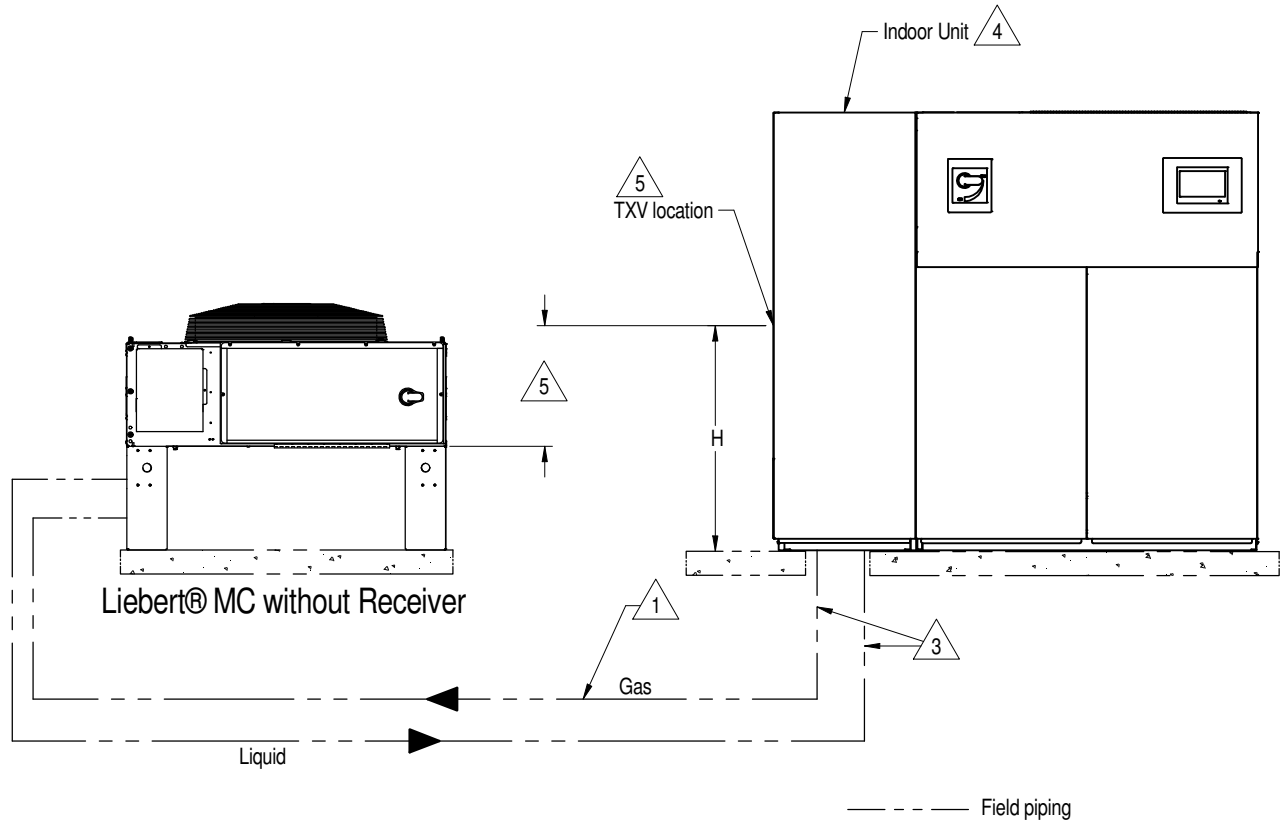

**Notes:**

1. Pitch horizontal hot gas piping at a minimum of 1/2" per 10 feet (42mm per 10m) so that gravity will aid in moving oil in the direction of the refrigeration flow.
2. Single circuit condenser shown.
3. Unit piping entrance varies by unit and may be through the top of the unit.
4. Indoor unit may be Liebert® DS, Liebert® PDX, or Liebert® CRV and is shown for reference only.
5. The bottom of the coil must be less than 15' (4.6m) below the elevation of the TXV inside the indoor unit.  
Contact your Vertiv sales representative for additional information.

Internal TXV Height	H in. (mm)
Liebert® PDX Downflow	44 (1118)
Liebert® PDX Upflow	20 (508)
Liebert® DS	43 (1092)
Liebert® CRV - CR019	45 (1143)
Liebert® CRV - CR020/CR035	27 (686)

## AIR COOLED PIPING SCHEMATIC CONDENSER BELOW INDOOR UNIT

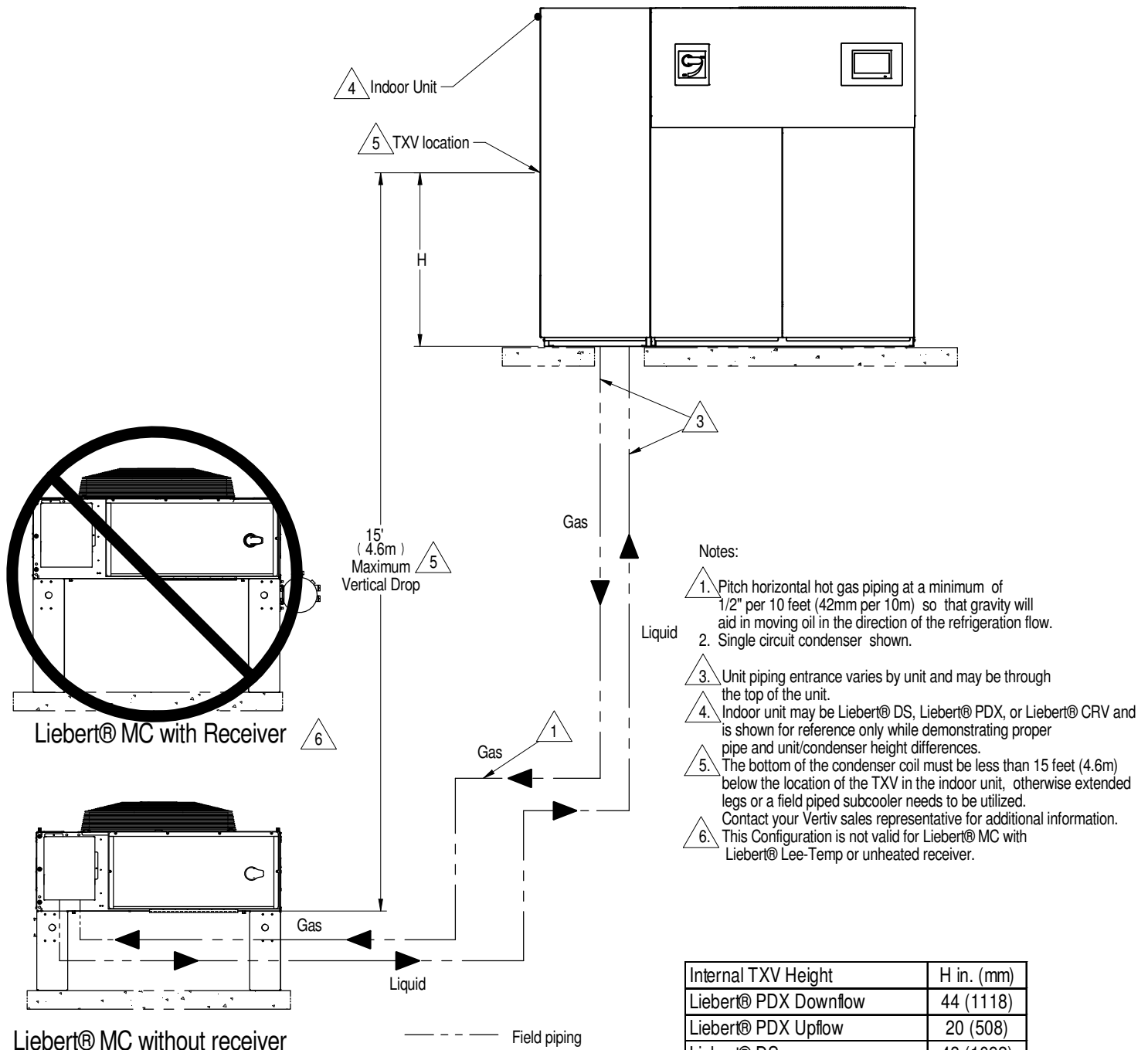

Internal TXV Height	H in. (mm)
Liebert® PDX Downflow	44 (1118)
Liebert® PDX Upflow	20 (508)
Liebert® DS	43 (1092)
Liebert® CRV - CR019	45 (1143)
Liebert® CRV - CR020/CR035	27 (686)

## GENERAL ARRANGEMENT DIAGRAM 600mm WATER/GLYCOL COOLED MODELS

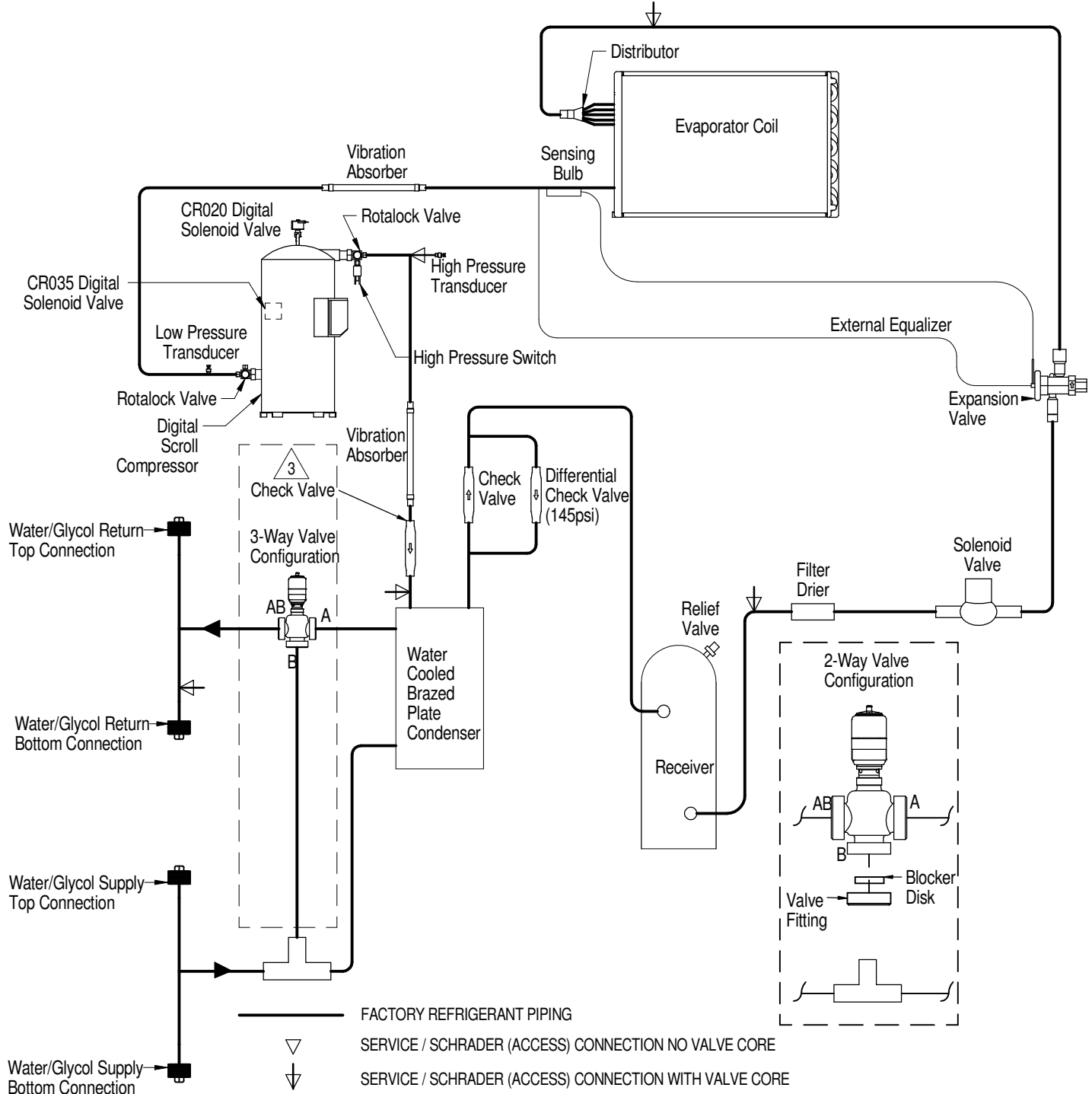

**NOTES:**

1. Schematic representation shown. Do not use for specific connection locations.
2. Install a 20 mesh strainer, in an easily accessible location, on the Water/Glycol Supply to prevent particles from entering the Heat Exchanger. Strainer Bypass Valves are recommended to allow the strainer to be cleaned while maintaining flow to the cooling unit.
3. Check Valve supplied only on CR020RW units.



## GENERAL ARRANGEMENT DIAGRAM 300mm (12in.) WATER/GLYCOL COOLED MODELS

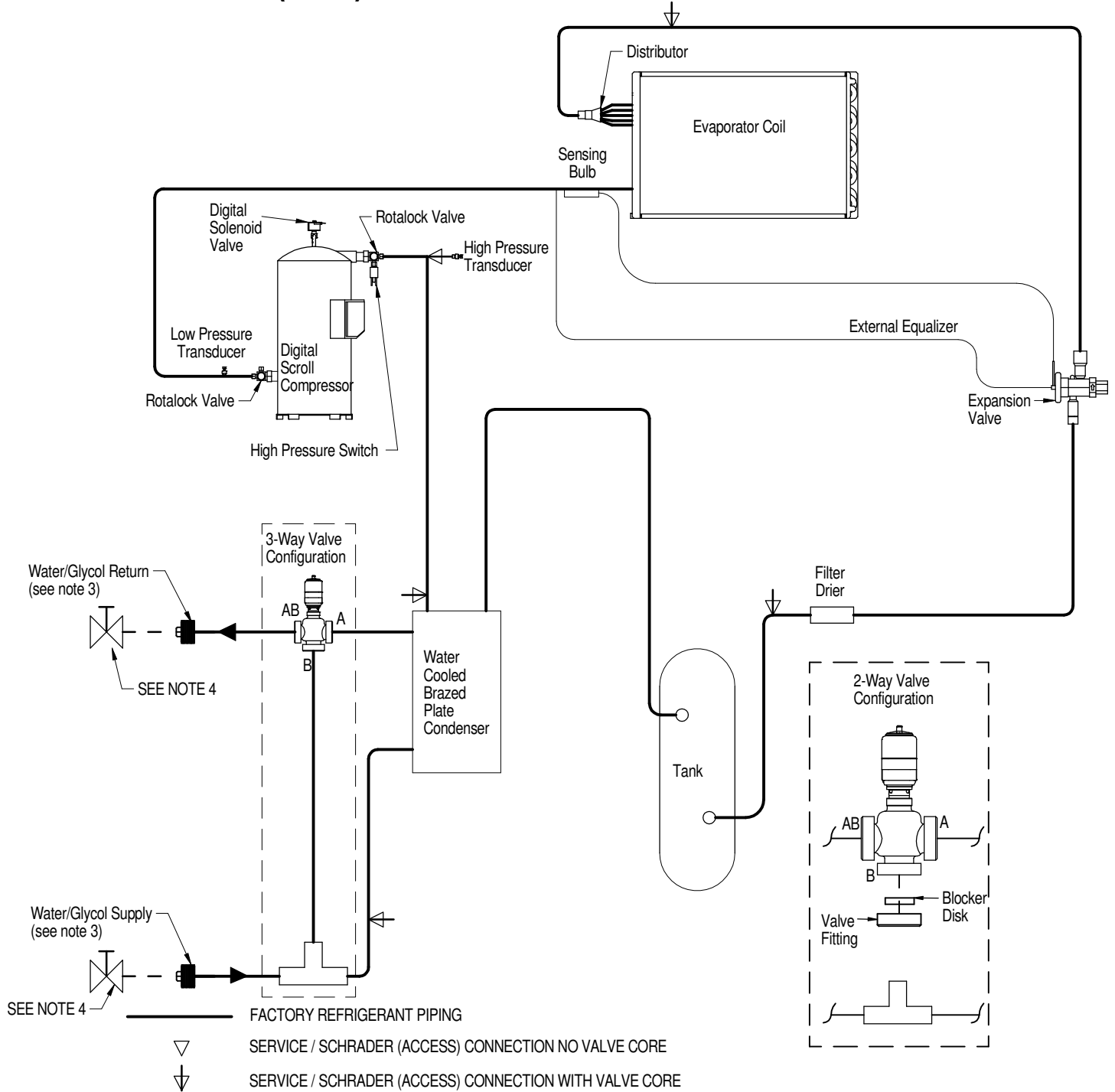

**NOTES:**

1. SCHEMATIC REPRESENTATION SHOWN. DO NOT USE FOR SPECIFIC CONNECTION LOCATIONS.
2. INSTALL A 20 MESH STRAINER, IN AN EASILY ACCESSIBLE LOCATION, ON THE WATER/GLYCOL SUPPLY TO PREVENT PARTICLES FROM ENTERING THE HEAT EXCHANGER. STRAINER BYPASS VALVES ARE RECOMMENDED TO ALLOW THE STRAINER TO BE CLEANED WHILE MAINTAINING FLOW TO THE COOLING UNIT.
3. UNIT CONNECTIONS MAY BE ORDERED TOP OR BOTTOM.
4. VALVE NOT PROVIDED BY VERTIV™ BUT ARE REQUIRED FOR PROPER CIRCUIT OPERATION AND MAINTENANCE. THEY SHOULD BE LOCATED NEAR THE LIEBERT® CRV300 UNIT.

**PRIMARY CONNECTION LOCATIONS**  
**CR020RW & CR035RW WATER/GLYCOL MODELS** Rear View  
 (components removed for clarity)

Notes:

1. Piping and Electrical connections available at the top & bottom of unit.
2. Install a 35 mesh strainer, in an easily accessible location, on the Water/Glycol Supply to prevent particles from entering the heat exchanger. Strainer bypass valves are recommended to allow the strainer to be cleaned while maintaining flow to the cooling unit.

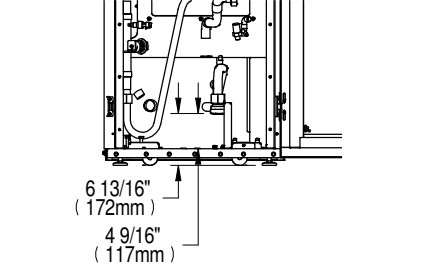
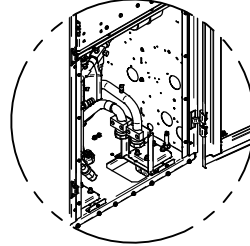
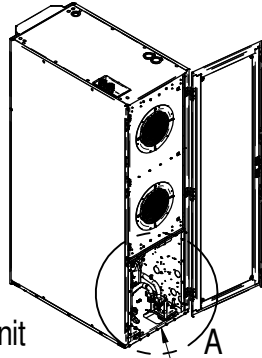

Rear of Unit

DETAIL A

Rear of Unit

(Internal Piping and top of unit removed for clarity)

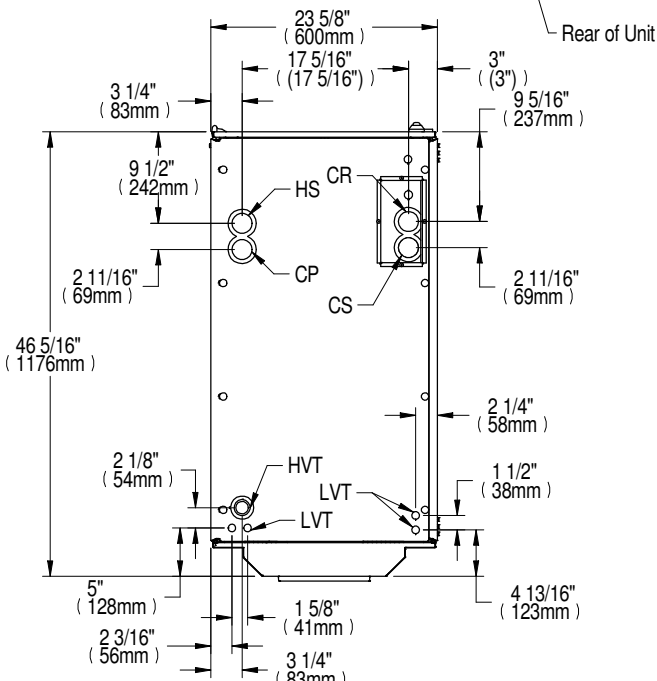

Top View showing Top Connections

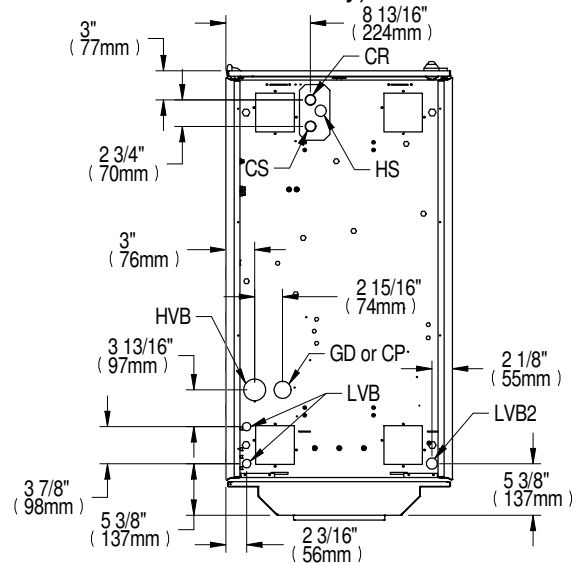

Top View showing Bottom Connections  
 (possible with raised floor)

Unit Connections		CR020RW	CR035RW
CS	Water/Glycol Coolant Supply	1-1/4 NPT Female	
CR	Water/ Glycol Coolant Return		
GD	Gravity/Coil Pan Drain	1" NPT Male	
HS	Humidifier Supply	1/2" NPT Female (top connection) 1/4" Compression Fitting (bottom connection)	
CP	Condensate Pump	1/2" NPT Female	
HVT	High Voltage Top Connection	Combination Knockout Hole Diameter 35mm (1-3/8"), 45mm (1-3/4" and 64mm (2-1/2"))	
HVB	High Voltage Bottom Connection (feed through base of unit)	Knockout Hole Diameter 64mm (2-1/2")	
LVT	Low Voltage Top Connection	Knockout Hole Diameter 22mm (7/8") 4 places	
LVB	Low Voltage Bottom Entrance	Knockout Hole Diameter 28mm (1-1/8") 2 places	
LVB2	(feed through base of unit)	Knockout Hole Diameter 45mm (1-3/4") 1 place	

## PRIMARY CONNECTION LOCATIONS 300mm (12in.) WATER/GLYCOL COOLED MODELS

PIPING CONNECTION LOCATIONS MUST BE ORDERED TOP OR BOTTOM.  
ELECTRICAL CONNECTIONS AVAILABLE TOP OR BOTTOM OF UNIT.

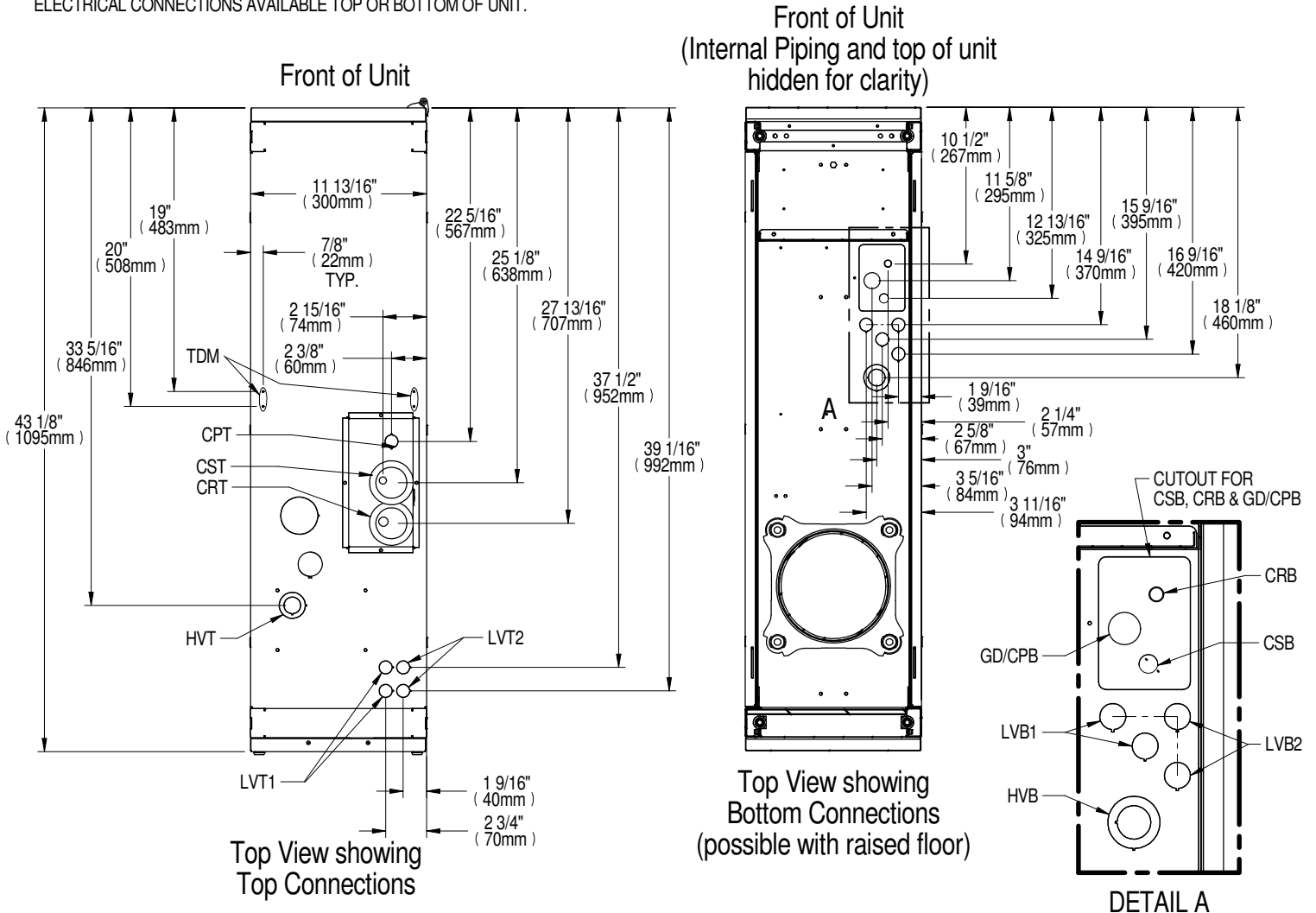

Unit Top Connections		CR019 (60Hz)	Unit Bottom Connections		CR019 (60 Hz)
CST	Water/Glycol Coolant Supply	1-1/4" NPT Female	CSB	Water/Glycol Coolant Supply	1-1/4" NPT Female
CRT	Water/Glycol Coolant Return		CRB	Water/Glycol Coolant Return	
CPT	Condensate Pump	Knockout Hole Ø1-3/8" (35mm)	GD	Gravity Coil Pan Drain	Knockout Hole Ø1-3/4" (44mm)
HVT	High Voltage	Combination Knockout Ø1-1/8" (29mm) & Ø1-3/4" (44mm)	CPB	Condensate Pump	
LVT1	Low Voltage (Twisted Pair)	Knockout Hole Ø7/8" (22mm) 2 plcs.	HVB	High Voltage Bottom Entrance (feed through the bottom of unit)	Combination Knockout Ø1-1/8" (29mm) & Ø1-3/4" (44mm)
LVT2	Low Voltage (Shielded Cable)		LVB1	Low Voltage (Twisted Pair)	Knockout Hole Ø7/8" (22mm) 2 plcs.
TDM	Tie Down (Top) Mounting	Hole Ø1/8" (3mm) 4 plcs.	LVB2	Low Voltage (Shielded Cable)	

## GENERAL ARRANGEMENT DIAGRAM 600mm (24in.) CHILLED WATER MODELS

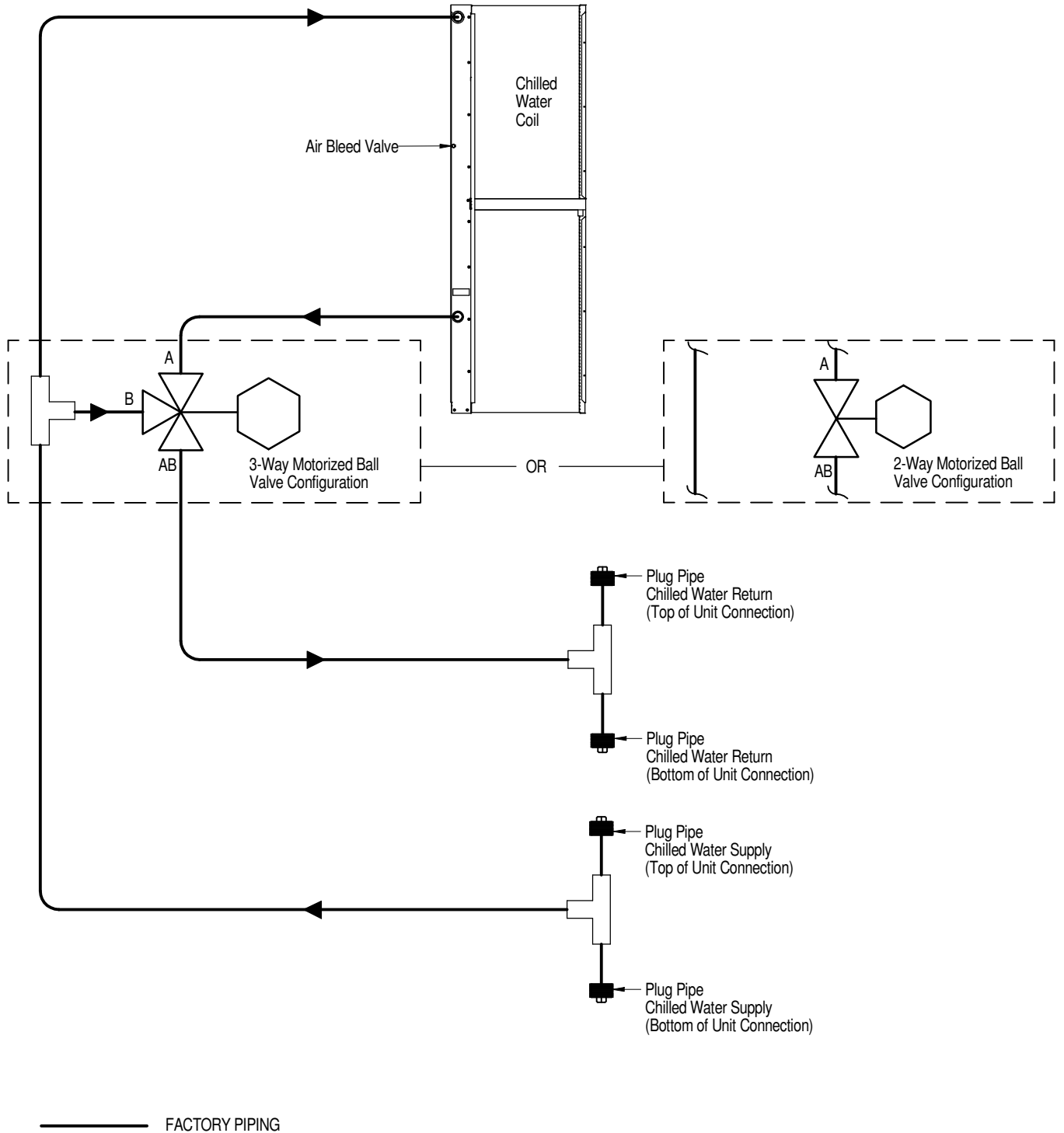

NOTE: SCHEMATIC REPRESENTATION SHOWN. DO NOT USE FOR SPECIFIC CONNECTION LOCATIONS.



## GENERAL ARRANGEMENT DIAGRAM 300mm (12in.) CHILLED WATER MODELS

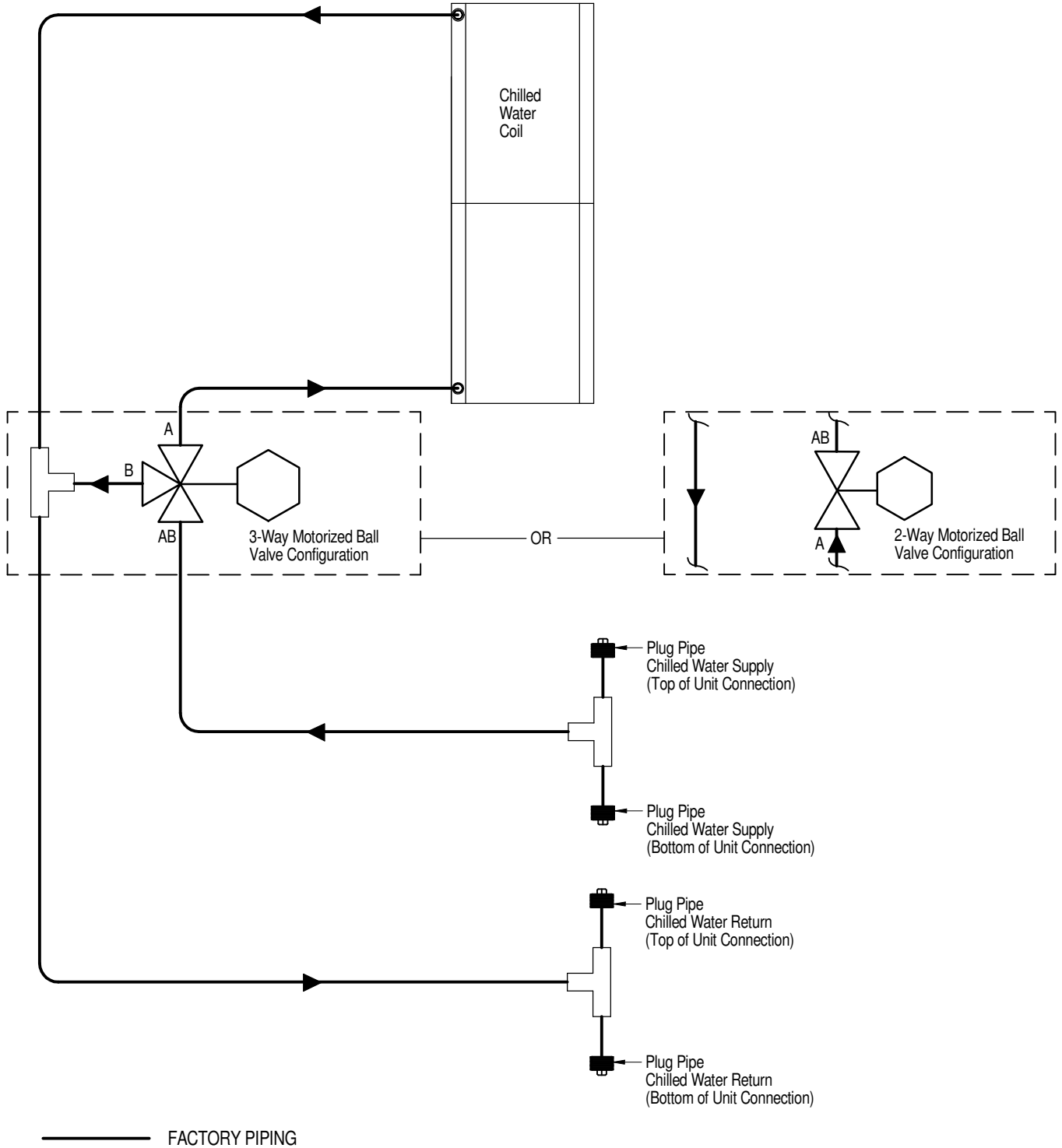

NOTE: SCHEMATIC REPRESENTATION SHOWN. DO NOT USE FOR SPECIFIC CONNECTION LOCATIONS.

**PRIMARY CONNECTION LOCATIONS  
CR040 CHILLED WATER MODELS**

Notes:  
1. Piping and Electrical connections available at the top & bottom of unit.

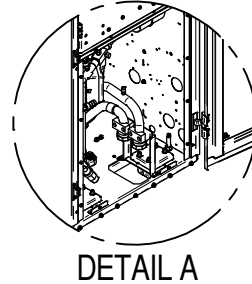
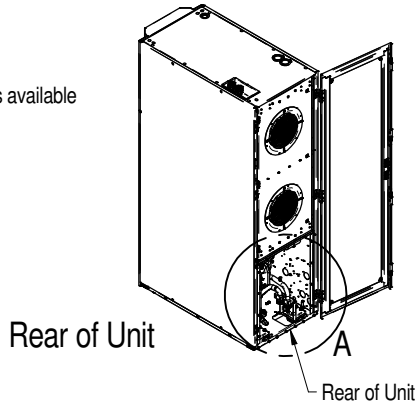

Rear View  
(components removed for clarity)

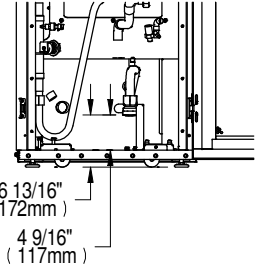

Rear of Unit  
(Internal Piping and top of unit removed for clarity)

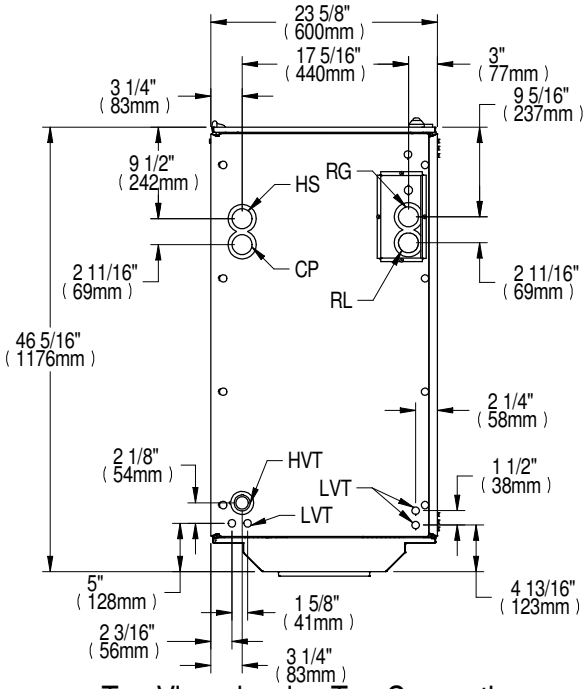
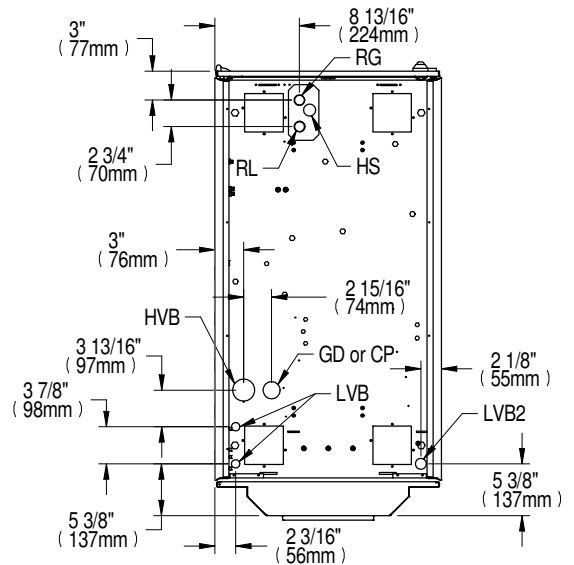

Top View showing Top Connections

Top View showing Bottom Connections  
(possible with raised floor)

Unit Connections		CR040
CS	Chilled Water Supply	1-1/4 NPT Female
CR	Chilled Water Return	
GD	Gravity/Coil Pan Drain	1" NPT Male
HS	Humidifier Supply	1/2" NPT Female (top connection) 1/4" Compression Fitting (bottom connection)
CP	Condensate Pump	1/2" NPT Female
HVT	High Voltage Top Connection	Combination Knockout Hole Diameter 35mm (1-3/8"), 45mm (1-3/4" and 64mm (2-1/2"))
HVB	High Voltage Bottom Connection (feed through base of unit)	Knockout Hole Diameter 64mm (2-1/2")
LVT	Low Voltage Top Connection	Knockout Hole Diameter 22mm (7/8") 4 places
LVB	Low Voltage Bottom Entrance (feed through base of unit)	Knockout Hole Diameter 28mm (1-1/8") 2 places
LVB2		Knockout Hole Diameter 45mm (1-3/4") 1 place

## PRIMARY CONNECTION LOCATIONS 300mm (12in.) CHILLED WATER MODELS

PIPING AND ELECTRICAL CONNECTIONS AVAILABLE AT THE TOP AND BOTTOM OF UNIT.

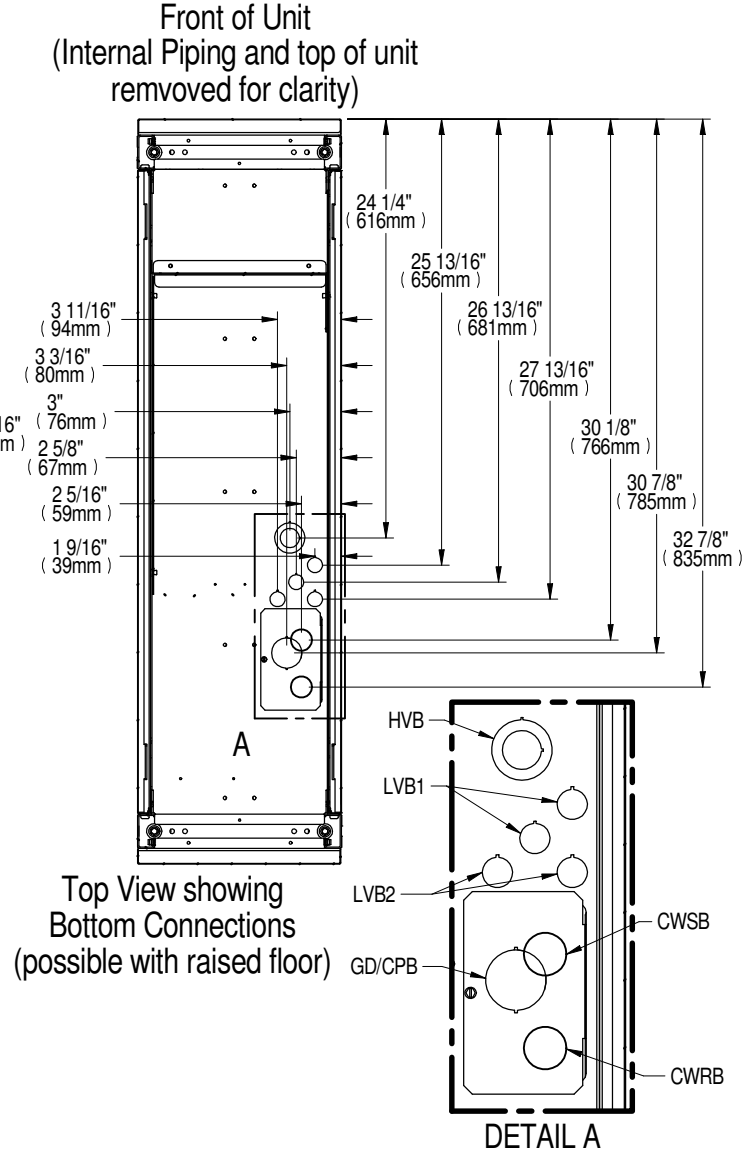
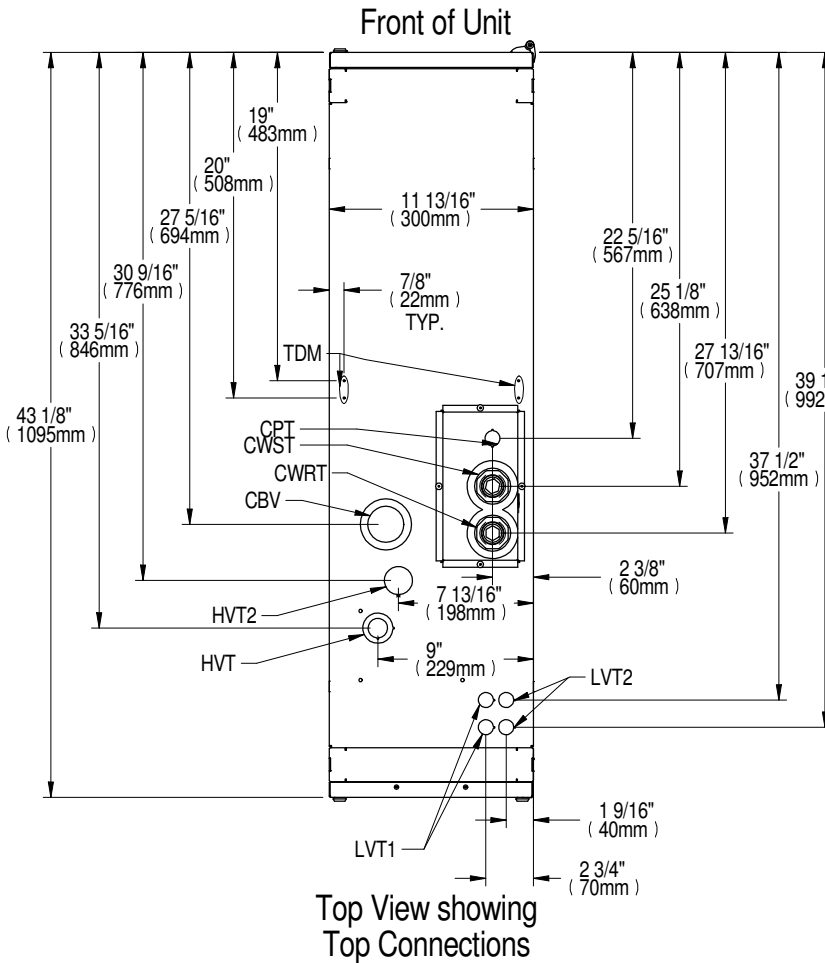

Unit Top Connections		CR032RC (60Hz)	Unit Bottom Connections		CR032RC (60Hz)
CWST	Chilled Water Supply	1-1/4" NPT Female	CWSB	Chilled Water Supply	1-1/4" NPT Female
CWRT	Chilled Water Return		CWRB	Chilled Water Return	
CPT	Condensate Pump	Knockout Ø1-3/8" (35mm)	GD	Gravity Coil Pan Drain	Knockout Ø1-3/4" (44mm)
CBV	Coil Bleeder (Schrader Valve Access)	Rubber Plug Ø2" (51mm)	CPB	Condensate Pump	
HVT	High Voltage	Combination Knockout Ø1-1/8" (29mm) & 1-3/4"	HVB	High Voltage Bottom Entrance (feed through bottom of unit)	Combination Knockout Ø1-1/8" (29mm) & Ø1-3/4"
HVT2	High Voltage (120V Units)	Knockout Ø1-3/4" (44mm)	LVB1	Low Voltage (Twisted Pair)	Knockout Ø7/8" (22mm) 2 plcs.
LVT1	Low Voltage (Twisted Pair)	Knockout Ø7/8" (22mm) 2 plcs.	LVB2	Low Voltage (Shielded Cable)	
LVT2	Low Voltage (Shielded Cable)				
TDM	Tie Down (Top) Mounting	Hole Ø1/8" (3mm)			



## ELECTRICAL FIELD CONNECTIONS DESCRIPTIONS 600mm (24in.) MODELS

### STANDARD ELECTRICAL CONNECTIONS

- 1) **High voltage connection through the bottom of the electric panel** – 1-3/8" (34.9mm), 1-3/4" (44.5mm) & 2-1/2" (64mm) diameter concentric knockout.
- 2) **Low voltage connection through the bottom of the electric panel** - Quantity (2) 7/8" (22mm) diameter knockouts.
- 3) **High voltage connection through the top of the unit** – 1-3/8" (34.9mm), 1-3/4" (44.5mm) & 2-1/2" (64mm) diameter concentric knockout.
- 4) **Low voltage connection through the top of the unit** - Quantity (4) 7/8" (22mm) diameter knockouts.
- 5) **Three phase electrical service** – Connect to terminals on disconnect switch. Three phase service not by Liebert®. (see page 2 for an important note regarding unit electrical service)
- 6) **Factory Installed locking Disconnect Switch**
- 7) **Earth ground** - Terminal for field supplied earth grounding wire.
- 8) **Remote unit shutdown** - Replace existing jumper between terminals 37 & 38 with field supplied normally closed switch having a minimum 75VA, 24VAC rating. Use field supplied Class 1 wiring.
- 9) **Customer alarm inputs** - Terminals for field supplied, normally closed contacts, having a minimum 75VA, 24VAC rating, between terminals 3 & 50, 2 & 51, 5 & 55, or 3 & 56. Use field supplied Class 1 wiring. Terminal 3 & 56 are used for humidifier alarm when a humidifier is installed. The remaining terminals are available for customer alarm inputs, such as; smoke sensors and building fire alarms.
- 10) **Common alarm** - On any alarm, normally open dry contact is closed across terminals 75 & 76 for remote indication. 1 AMP, 24VAC max load. Use Class 1 field supplied wiring.
- 11) **Heat rejection interlock** - On any call for compressor operation, normally open dry contact is closed across terminals 70 & 71 to heat rejection equipment. 1 AMP, 24VAC max load. Use Class 1 field supplied wiring.

### STANDARD ELECTRICAL CONNECTIONS

- 12) **CANbus Connector** – Terminal block with terminals 49-1 (CAN-H) and 49-3 (CAN-L) + SH (shield connection). The terminals are used to connect the CANbus communication cable (provided by others) from the indoor unit to the Liebert® MC.
- 13) **CANbus Cable** – CANbus cable provided by others to connect to the outdoor condenser. No special considerations are required when the total external cable connection between the indoor unit and outdoor unit(s) is less than 450FT (137M). For total external cable connections greater than 450FT (137M) but less than 800FT (243M) a CANbus isolator is required. Contact the Factory.  
Cable must have the following specifications:  
Braided shield or foil shield with drain wire
  - Shield must be wired to ground at indoor unit
  - 22-18AWG stranded tinned copper
  - Twisted pair (minimum 4 twists per foot)
  - Low Capacitance (15pF/FT or less)
  - Must be rated to meet local codes and conditions
  - EXAMPLES BELDEN 89207 (PLENUM RATED), OR ALPHA WIRE 6454 CATEGORY 5, 5E, OR HIGHER
- 14) Do not run in same conduit, raceway, or chase as high voltage wiring.
- 15) For CANbus network lengths greater than 450FT (137M) call Factory.



# LIEBERT® CRV

---

## ELECTRICAL FIELD CONNECTIONS DESCRIPTIONS

### 600mm (24in.) MODELS

#### ELECTRICAL CONNECTIONS FOR OPTIONAL FEATURES

- 16) **Condensate pump high water alarm** (available when optional pump is installed) - On pump high water indication, normally open dry contact is closed across terminals 88 & 89 for remote indication. 1 AMP, 24VAC max load. Use Class 1 field supplied wiring.
- 17) **Liebert® LiquiTect shutdown and dry contact** (available when optional Liebert® LiquiTect sensor is installed) – On Liebert® LiquiTect activation, normally open dry contact is closed across terminals 58 & 59 for remote indication. The Liebert® LiquiTect sensor notifies Liebert® iCOM™ of indication through terminals 60 & 61. 1 AMP, 24VAC max load. Use Class 1 field supplied wiring.
- 18) **Reheat and humidifier lockout** – Remote 24VAC required at terminals 82 & 83 for lockout of reheat and humidifier.
- 19) **Additional Common Alarm** - On any alarm, one additional normally open dry contact is closed across terminals 94 & 95 for remote indication. 1 AMP, 24VAC max load. Use Class 1 field supplied wiring.

NOTE: Refer to specification sheet for total unit full load amps, wire size amps and max overcurrent protective device size.

#### Important note for 460V rated Liebert® CRV units (CR\*\*\*\*\*A)

The electronically commutated (EC) motors included in the Liebert® CRV unit are suitable for connection to an electrical service providing input power to the unit with 300V or less line to ground potential only.

Acceptable unit input electrical service for 460V (480V) nominal units

- 480V wye with solidly grounded neutral and 277V line to ground

Un-acceptable unit input electrical service for 460V (480V) nominal units

- wye with high resistance (or impedance) ground
- delta without ground or with floating ground
- delta with corner ground
- delta with grounded center tap

## ELECTRICAL FIELD CONNECTIONS DESCRIPTIONS

### 600mm (24in.) MODELS

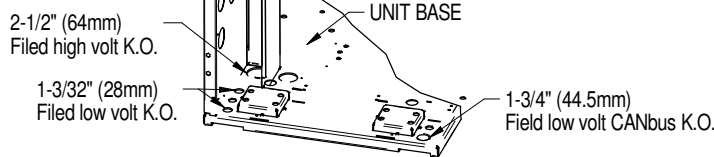
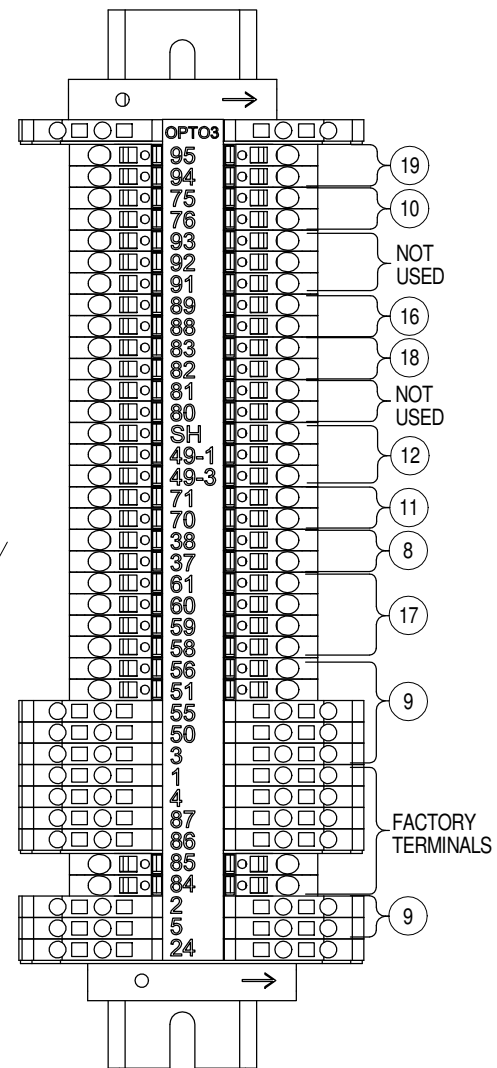
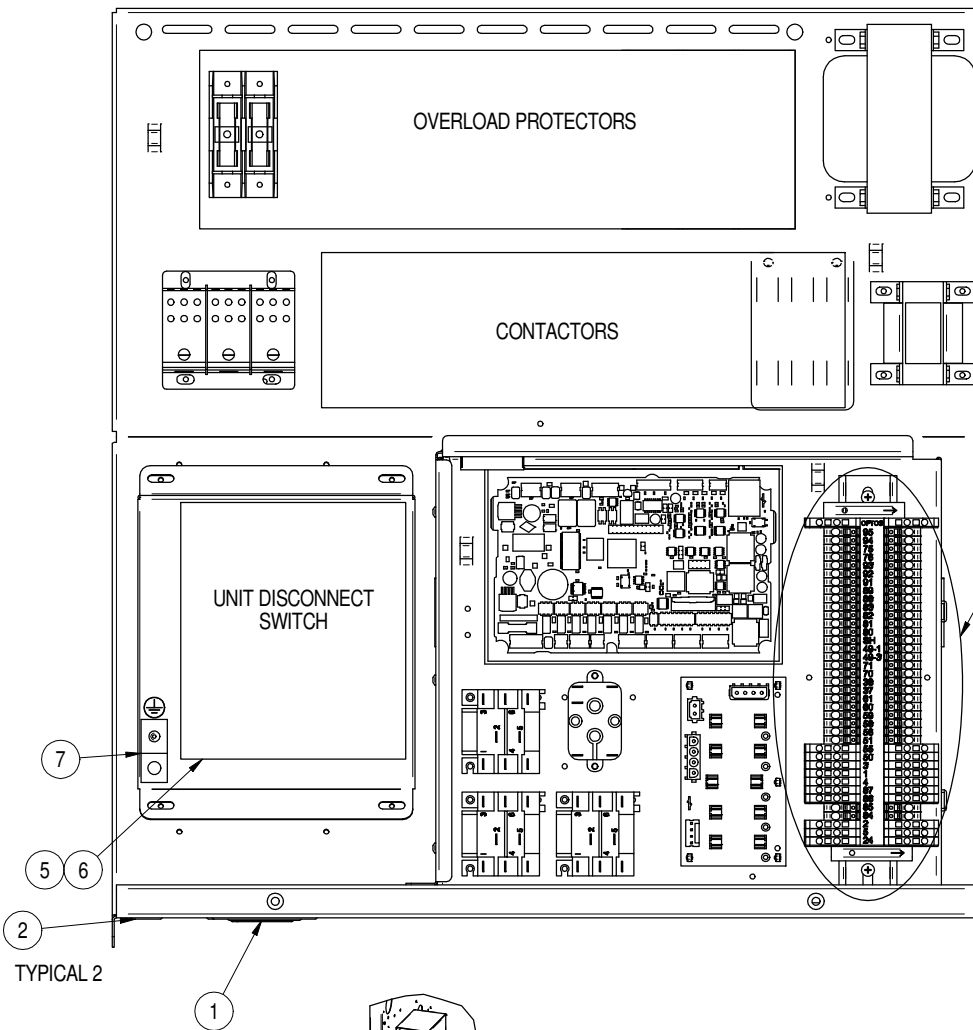
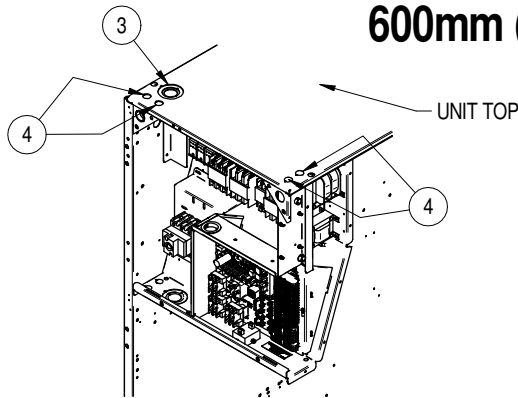

## CANbus & INTERLOCK CONNECTIONS BETWEEN 600mm (24in.) UNIT & LIEBERT® MC (PREMIUM)

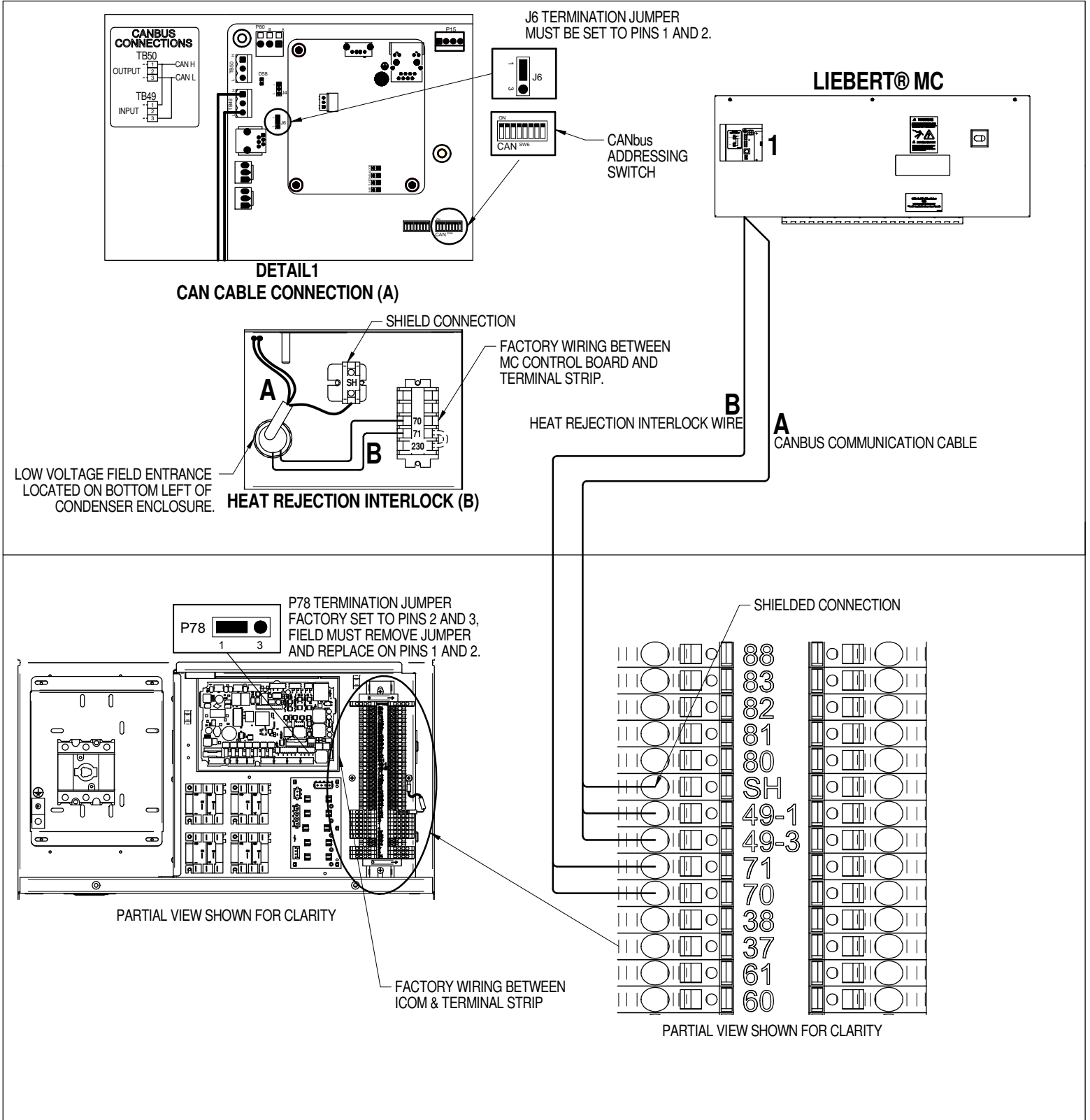



# LIEBERT® CRV

---

## CANbus & INTERLOCK CONNECTIONS BETWEEN 600mm (24in.) UNIT & LIEBERT® MC (PREMIUM)

### COMPONENT NOTES:

1. COMPONENT APPEARANCE, ORIENTATION, AND POSITION MAY VARY  
TERMINAL NAMES AND CALLOUTS REMAIN CONSTANT.
2. ALL CIRCUITS TO THESE CONNECTION POINTS ARE CLASS 2.

### CAN & CABLE NOTES (A):

1. CABLE MUST HAVE THE FOLLOWING SPECIFICATIONS:
  - BRAIDED SHIELD OR FOIL SHIELD WITH DRAIN WIRE
  - SHIELD MUST BE WIRED TO GROUND AT INDOOR UNIT
  - 22-18AWG STRANDED TINNED COPPER
  - TWISTED PAIR (MINIMUM 4 TWISTS PER FOOT)
  - LOW CAPACITANCE (15pF/FT OR LESS)
  - MUST BE RATED TO MEET LOCAL CODES AND CONDITIONS.
  - EXAMPLES BELDEN 89207 (PLENUM RATED), OR ALPHA WIRE 6454 CATEGORY 5, 5E, OR HIGHER.
2. DO NOT RUN IN SAME CONDUIT, RACEWAY, OR CHASE AS HIGH VOLTAGE WIRING.
3. FOR CANBUS NETWORK LENGTHS GREATER THAN 450FT(137M), CONTACT FACTORY.

### INTERLOCK WIRE NOTES (B):

1. FIELD SUPPLIED WIRE
  - 2 CONDUCTOR 18AWG OR GREATER
  - RATED 600V
2. RUN FIELD SUPPLIED WIRES BETWEEN THE INDOOR UNIT AND THE CONDENSER.



## CONNECTION PATHS INTELLISLOT CABLE FOR 600mm (24 in.)

Cable Connection Entry

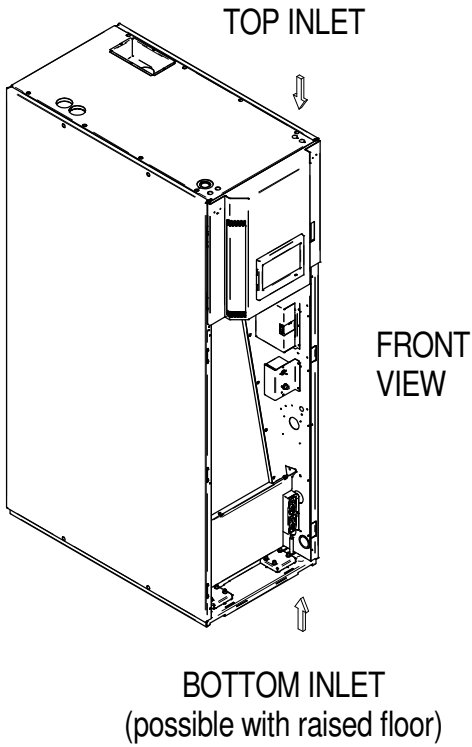

TOP INLET PATH

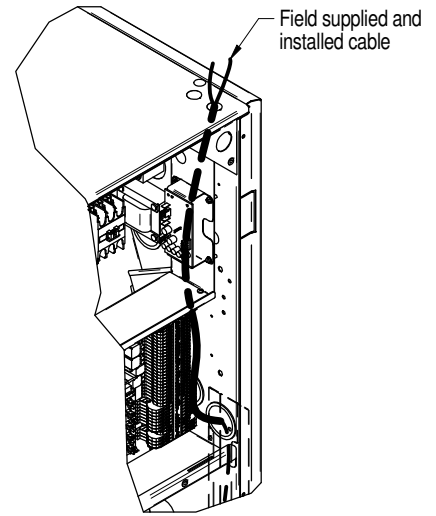

BOTTOM INLET PATH  
(possible with raised floor)

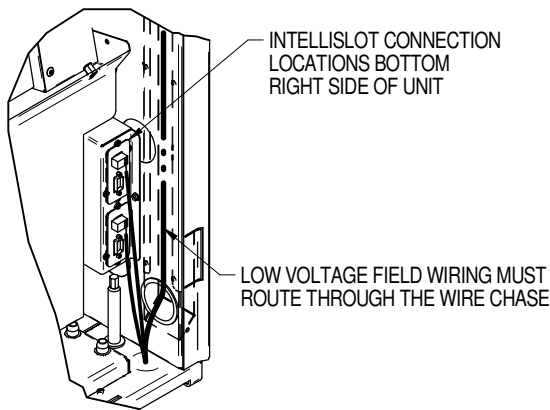

Notes:

1. All wiring connections must be made per local codes.

## UNIT TO UNIT NETWORK CONNECTIONS WITHIN NETWORK GROUP (FOR 3+ UNITS) 600MM (24in.) UNITS

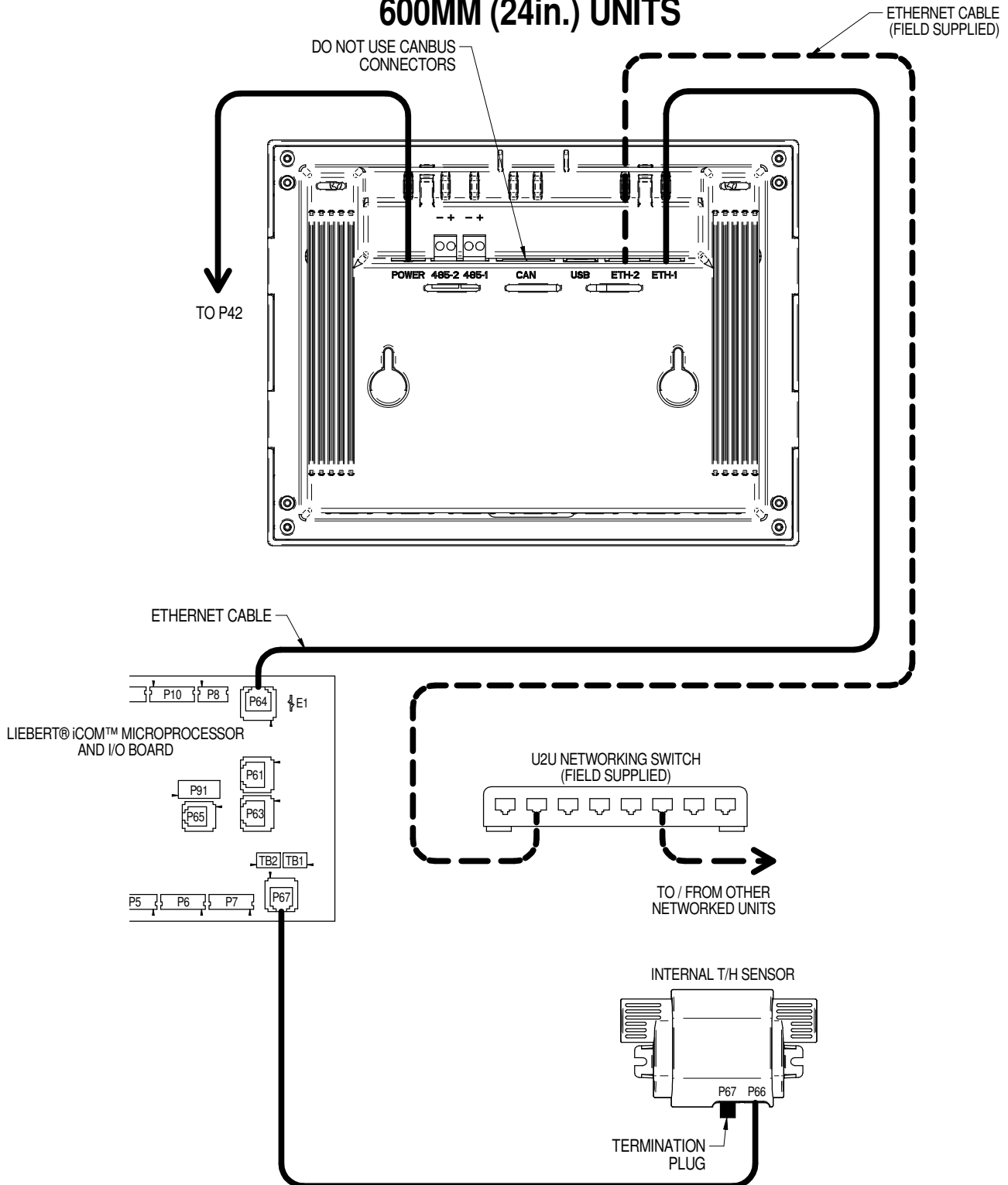

## UNIT TO UNIT NETWORK CONNECTIONS WITHIN NETWORK GROUP FOR DUAL-UNITS 600MM (24in.) UNITS

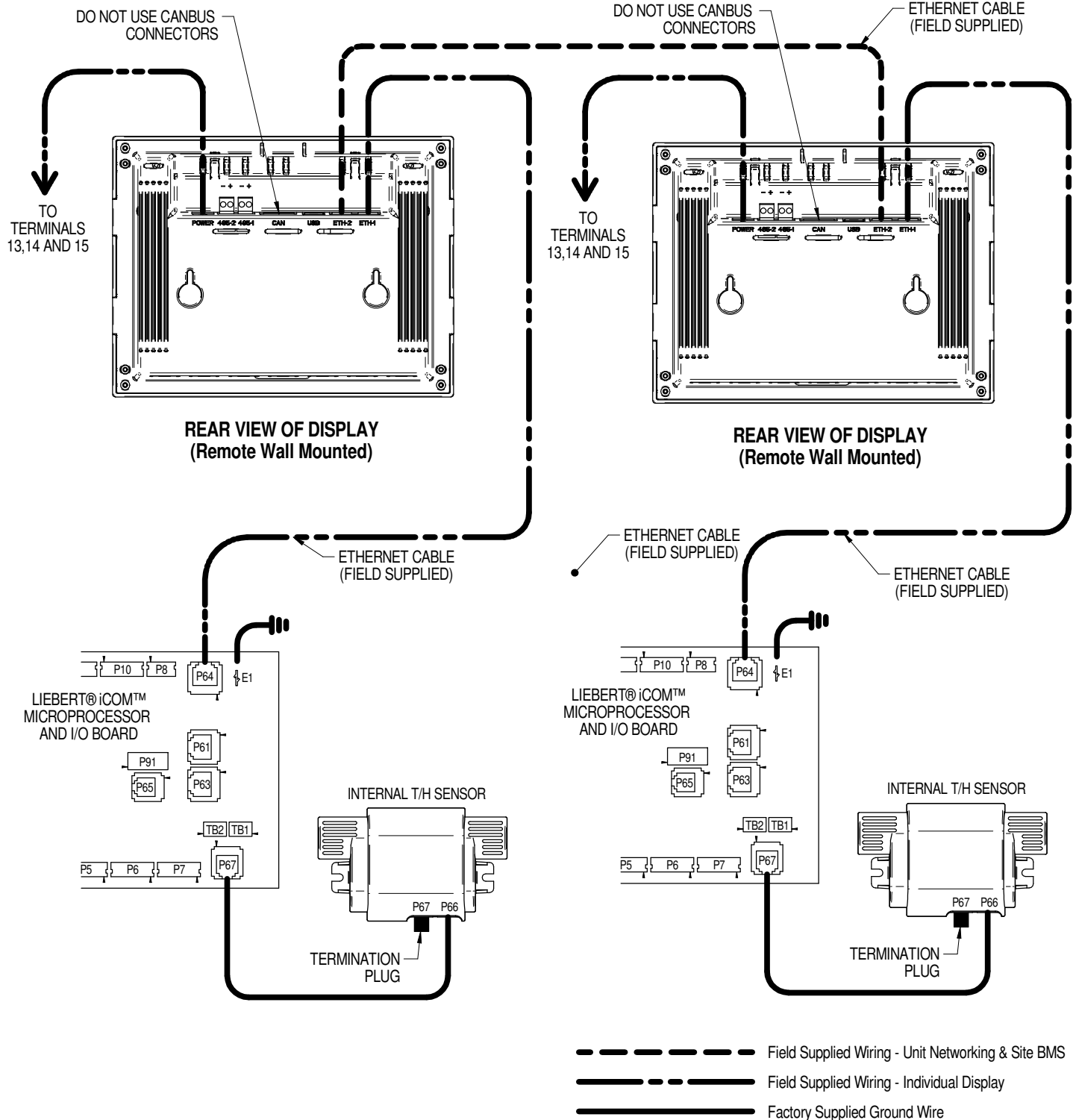



# LIEBERT® CRV

## ELECTRICAL FIELD CONNECTIONS DESCRIPTIONS 300mm (12in.) MODELS

### SAFETY INSTRUCTIONS: READ ALL SAFETY MESSAGES IN USER MANUAL BEFORE STARTING ELECTRICAL CONNECTIONS

#### STANDARD ELECTRICAL CONNECTIONS (See unit views for item callouts)

- 1) **High voltage connection through the rear of the disconnect switch box** – 1-1/8" (28.6mm) & 1-3/4" (44.5mm) diameter concentric knockout.
- 2) **High voltage connection through the top of the unit** – 1-1/4" (32mm) & 1-3/4" (44mm) diameter concentric knockout.
- 3) **Electrical service (hard wired)** – Refer to serial tag information for unit electrical service requirement.  
**Three phase** – 208/230V 60Hz  
**Three phase with Neutral** – 460V 60Hz Wye (5 wire: 3 phase + neutral + ground).  
**Single phase** – 208/230V 60Hz (Chilled Water only).  
Connect to terminals on disconnect switch. Electrical service not by Liebert®. Use copper conductors only, Wire per local codes. Refer to specification sheet for total unit full load amps, wire size amps and max over current protective device size.
- 4) **Electrical service (cord connected)** – Refer to serial tag information for unit electrical service requirement.  
**Single phase** – 120V 60Hz (Chilled Water only). 1-3/4" (44mm) diameter knockout provided in the top and bottom of the unit for the power cord to exit the unit. The power cord is Liebert® supplied with a L5-20 plug.
- 5) **Factory installed locking Disconnect Switch**
- 6) **Earth ground** - Terminal for field supplied earth grounding wire.
- 7) **Low voltage connection through the bottom of the unit** - Quantity (2) 7/8" (22mm) diameter knockouts, not shown.
- 8) **Low voltage connection through the top of the unit** - Quantity (2) 7/8" (22mm) diameter knockouts.
- 9) **Remote unit shutdown** - Replace existing jumper between terminals 37 & 38 with field supplied normally closed switch having a minimum 75VA, 24VAC rating. Use field supplied Class 1 wiring.
- 10) **Customer alarm inputs** - Terminals for field supplied, normally closed contacts, having a minimum 75VA, 24VAC rating, between terminals 3 & 50, 2 & 51, 5 & 55, or 3 & 56. Use field supplied Class 1 wiring. Terminals 5 & 55 not available when optional Condensate Pump is installed.
- 11) **Common alarm** - On any alarm, normally open dry contact is closed across terminals 75 & 76 for remote indication. 1 AMP, 24VAC max load. Use Class 1 field supplied wiring.
- 12) **Heat rejection interlock** - On any call for compressor operation, normally open dry contact is closed across terminals 70 & 71 to heat rejection equipment. 1 AMP, 24VAC max load. Use Class 1 field supplied wiring.

#### CANbus ELECTRICAL CONNECTIONS

- 13) **CANbus connector** – Terminal block with terminals 49-1 (CAN-H) and 49-3 (CAN-L) + SH (shield connection). The terminals are used to connect the CANbus communication cable (provided by others) from the indoor unit to the Liebert® MC.
- 14) **CANbus cable** – CANbus cable provided by others to connect to the outdoor condenser. No special considerations are required when the total external cable connection between the indoor unit and outdoor unit(s) is less than 450FT (137M). For total external cable connections greater than 450FT (137M) but less than 800FT (243M) a CANbus isolator is required. Contact the Factory.  
Cable must have the following specifications:
  - Braided shield or foil shield with drain wire
  - Shield must be wired to ground at indoor unit
  - 22-18AWG stranded tinned copper
  - Twisted pair (minimum 4 twists per foot)
  - Low Capacitance (15pF/FT or less)
  - Must be rated to meet local codes and conditions
  - EXAMPLES BELDEN 89207 (PLENUM RATED), OR ALPHA WIRE 6454 CATEGORY 5, 5E, OR HIGHER
- 15) Do not run in same conduit, raceway, or chase as high voltage wiring.
- 16) For CANbus network lengths greater than 450FT (137M) call Factory.



# LIEBERT® CRV

---

## ELECTRICAL FIELD CONNECTIONS DESCRIPTIONS

### 300mm (12in.) MODELS

**SAFETY INSTRUCTIONS: READ ALL SAFETY MESSAGES IN USER MANUAL  
BEFORE STARTING ELECTRICAL CONNECTIONS**

**ELECTRICAL CONNECTIONS FOR OPTIONAL FEATURES** (See unit views for item callouts)

- 17) **Condensate pump high water alarm** (available when optional pump is installed) - On pump high water indication, normally open dry contact is closed across terminals 88 & 89 for remote indication. 1 AMP, 24VAC max load. Use Class 1 field supplied wiring.
- 18) **Liebert® LiquiTect shutdown and dry contact** (available when optional Liebert® LiquiTect sensor is installed) – On Liebert® LiquiTect activation, normally open dry contact is closed across terminals 58 & 59 for remote indication. The Liebert® LiquiTect sensor notifies Liebert® iCOM™ of indication through terminals 60 & 61. 1 AMP, 24VAC max load. Use Class 1 field supplied wiring.
- 19) **Additional Common Alarm** – On any alarm, one additional normally open dry contact is closed across terminals 94 & 95 for remote indication. 1 AMP, 24VAC max load. Use Class 1 field supplied wiring.

## ELECTRICAL FIELD CONNECTIONS DESCRIPTIONS 300mm (12in.) MODELS

See page 4 for Disconnect Views

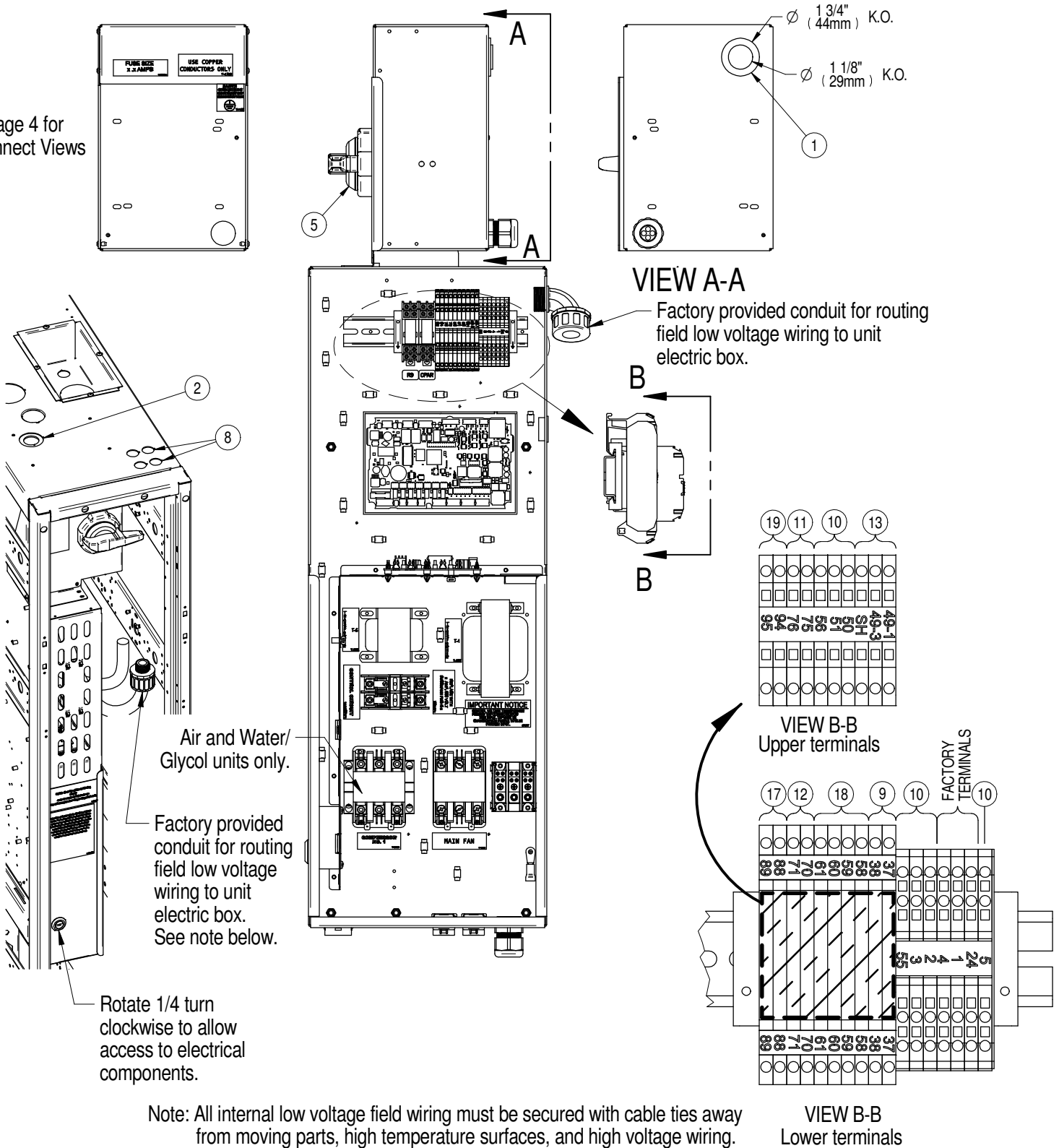

Note: All internal low voltage field wiring must be secured with cable ties away from moving parts, high temperature surfaces, and high voltage wiring.

## ELECTRICAL FIELD CONNECTIONS DESCRIPTIONS

### 300mm (12in.) MODELS

#### DISCONNECT VIEWS

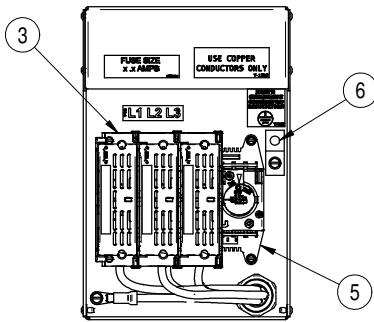

208/230V 3 phase

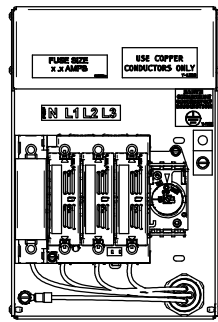

460V wye  
(3 phase + neutral + ground)

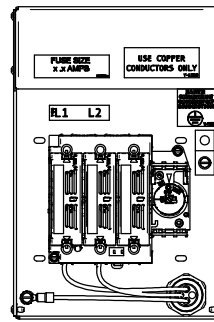

208/230V 1 phase  
(CW only)

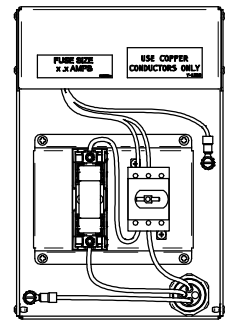

120V cord connected  
(CW only)

#### POWER SUPPLY REQUIREMENTS FOR 460V CRV 300 mm (12in.) UNITS

460V Wye Power Supply Connection  
(3 phase + Neutral + Ground)

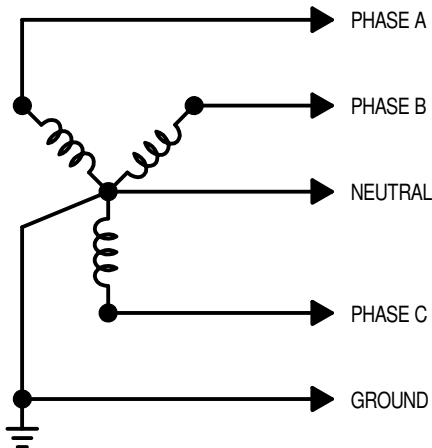

460V Delta Power Supply Connection

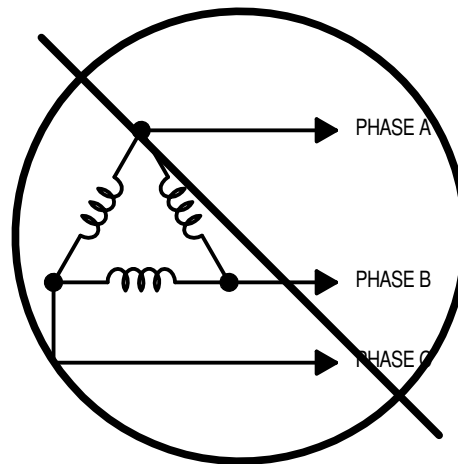

**NOTE**

The 460 volt Liebert® CRV 300 mm (12in.) unit is designed to operate with Wye-connected power with a solidly grounded neutral. It will not operate properly with Wye-connected power with high-resistance (or impedance) ground or with Delta-connected power.

**Acceptable Power Supplies—480V Nominal Units**

- 480V wye with solidly grounded neutral and 277V line-to-neutral

**Unacceptable Power Supplies— 480V Nominal Units**

- Wye with high-resistance (or impedance) ground
- Delta without ground or with floating ground
- Delta with corner ground
- Delta with grounded center tap

## ELECTRICAL FIELD CONNECTIONS DESCRIPTIONS 300mm (12in.) MODELS

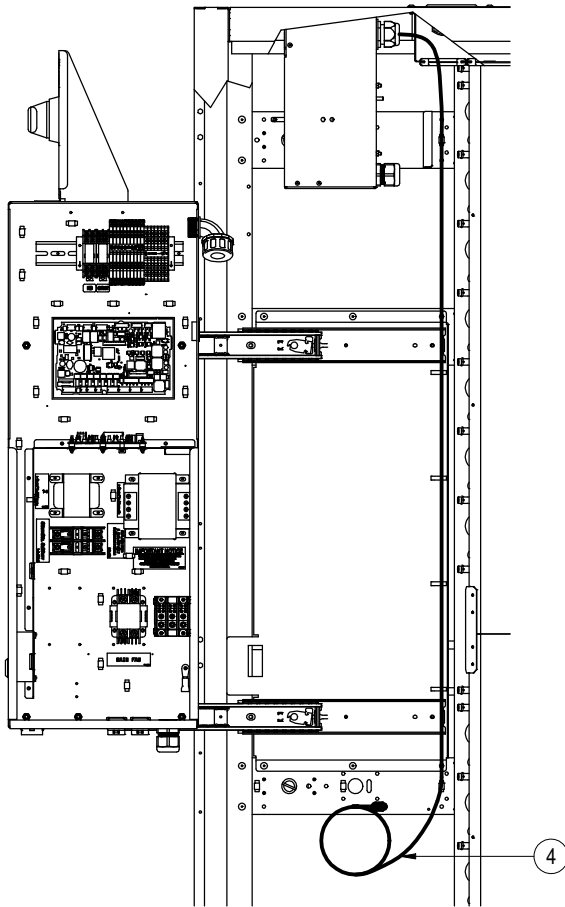

MAIN POWER CORD ROUTING - 120V CW UNITS

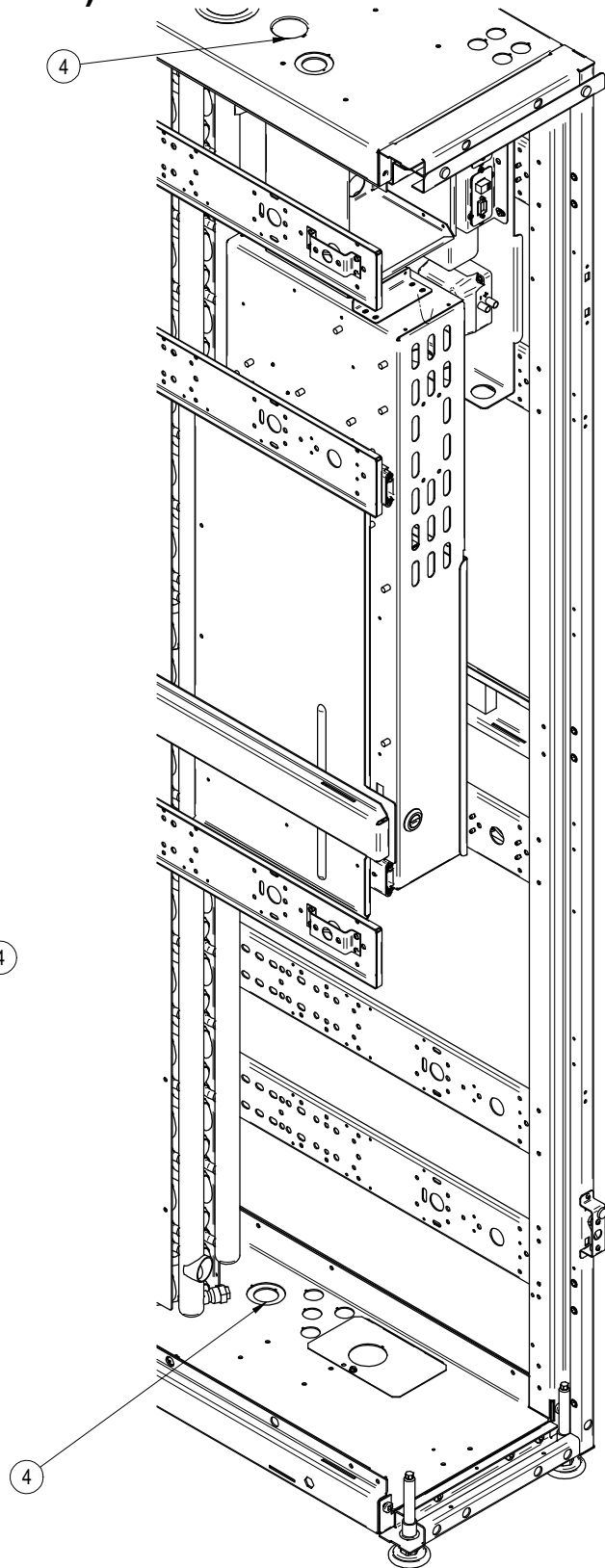



## CANbus & INTERLOCK CONNECTIONS BETWEEN 300mm (12in.) UNIT & LIEBERT® MC (PREMIUM)

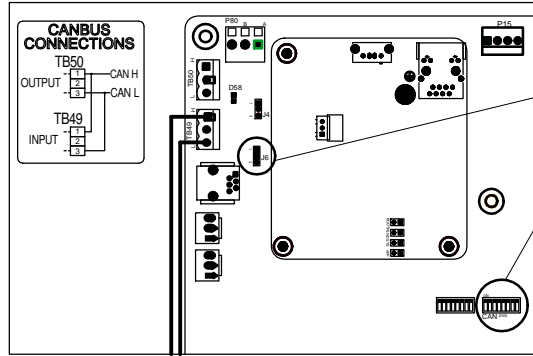

**DETAIL1  
CAN CABLE CONNECTION (A)**



J6 TERMINATION JUMPER  
MUST BE SET TO PINS 1 AND 2.



CANbus  
ADDRESSING  
SWITCH

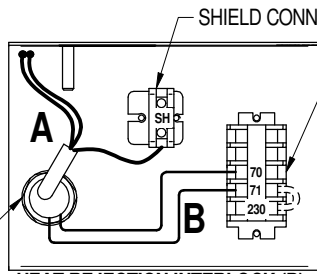
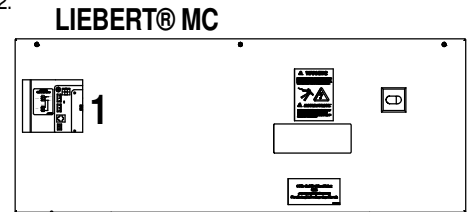

LOW VOLTAGE FIELD ENTRANCE  
LOCATED ON BOTTOM LEFT OF  
CONDENSER ENCLOSURE.

**HEAT REJECTION INTERLOCK (B)**

**LIEBERT® MC**

**1**

**A** CANbus CABLE CONNECTION

**B**  
HEAT REJECTION INTERLOCK

**COMPONENT NOTES:**

1. COMPONENT APPEARANCE, ORIENTATION AND POSITIONING MAY VARY. TERMINAL NAMES AND CALLOUTS REMAIN CONSTANT.
2. ALL CIRCUITS TO THESE CONNECTION POINTS ARE CLASS 2.

**CAN & CABLE NOTES (A):**

1. CABLE MUST HAVE THE FOLLOWING SPECIFICATIONS:
  - BRAIDED SHIELD OR FOIL SHIELD WITH DRAIN WIRE
  - SHIELD MUST BE WIRED TO GROUND AT INDOOR UNIT
  - 22-18AWG STRANDED TINNED COPPER
  - TWISTED PAIR (MINIMUM 4 TWISTS PER FOOT)
  - LOW CAPACITANCE (15pF/FT OR LESS)
  - MUST BE RATED TO MEET LOCAL CODES AND CONDITIONS.
  - EXAMPLES BELDEN 89207 (PLENUM RATED), OR ALPHA WIRE 6454 CATEGORY 5, 5E, OR HIGHER.
2. DO NOT RUN IN SAME CONDUIT, RACEWAY, OR CHASE AS HIGH VOLTAGE WIRING.
3. FOR CANBUS NETWORK LENGTHS GREATER THAN 450FT(137M) CONTACT FACTORY.

**INTERLOCK WIRE NOTES (B):**

1. FIELD SUPPLIED WIRE
  - 2 CONDUCTOR 18AWG OR GREATER
  - RATED 600V
2. RUN FIELD SUPPLIED WIRES BETWEEN THE INDOOR UNIT AND THE CONDENSER.

**CRV300 INDOOR UNIT**

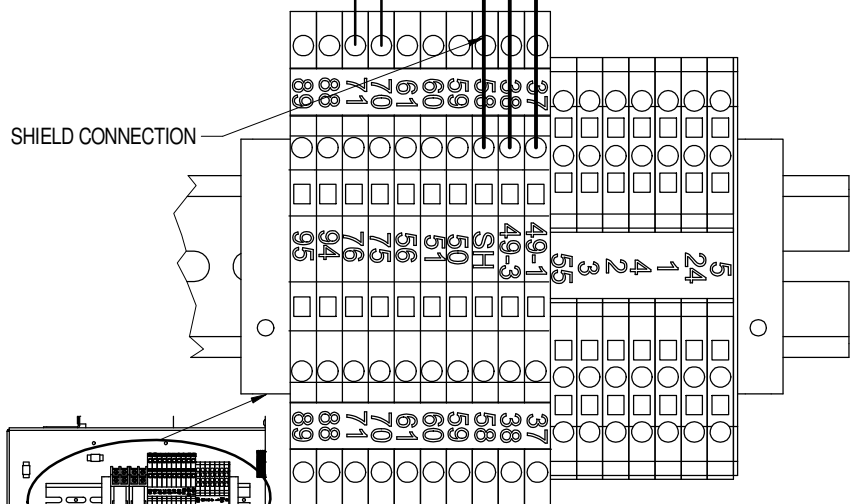

PARTIAL VIEW SHOWN FOR CLARITY

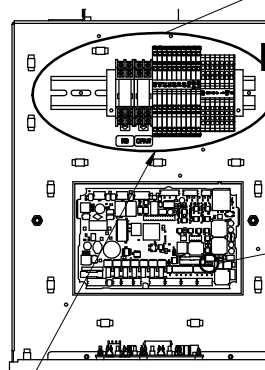

FACTORY WIRING BETWEEN ICOM AND TERMINAL STRIP.

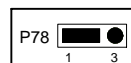

P78 TERMINATION JUMPER  
FACTORY SET TO PINS 2 AND 3,  
FIELD MUST REMOVE JUMPER  
AND REPLACE ON PINS 1 AND 2.

## LOW VOLTAGE FIELD WIRING ROUTING 300mm (12in.) ALL MODELS

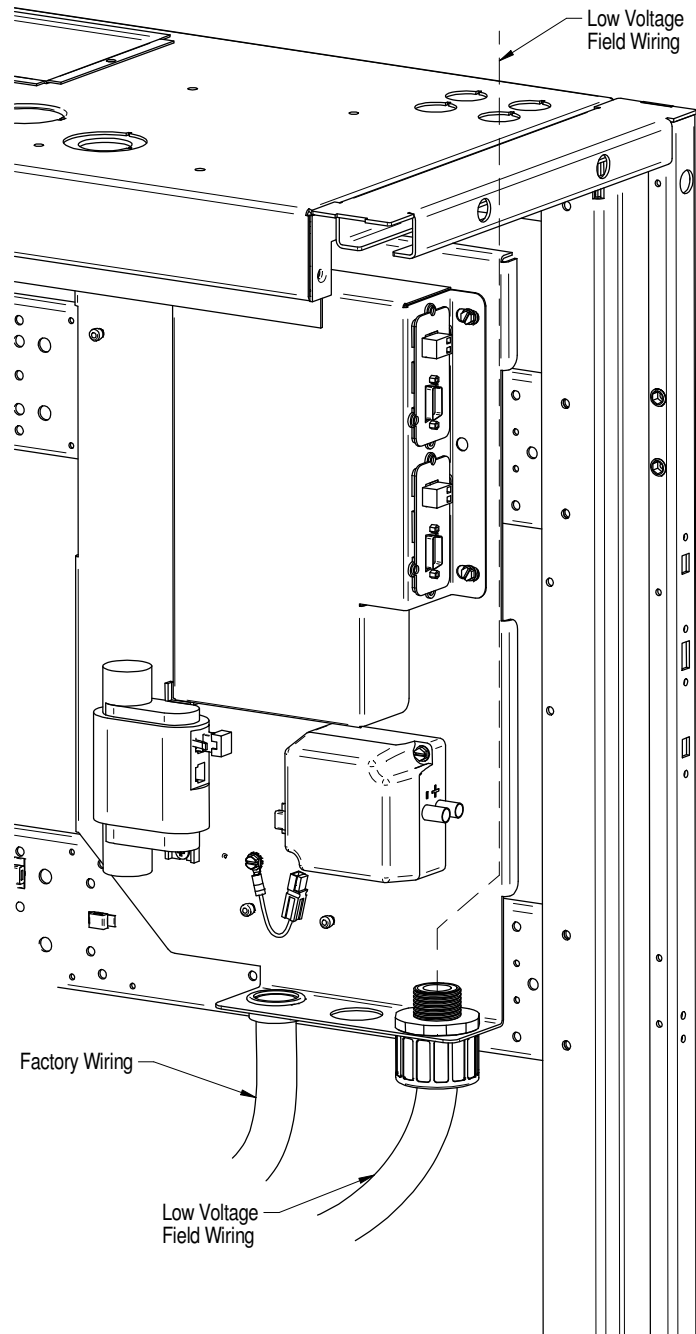

## POWER CABLE ROUTING BOTTOM ENTRY 300mm (12in.) AIR COOLED & WATER GLYCOL COOLED MODELS

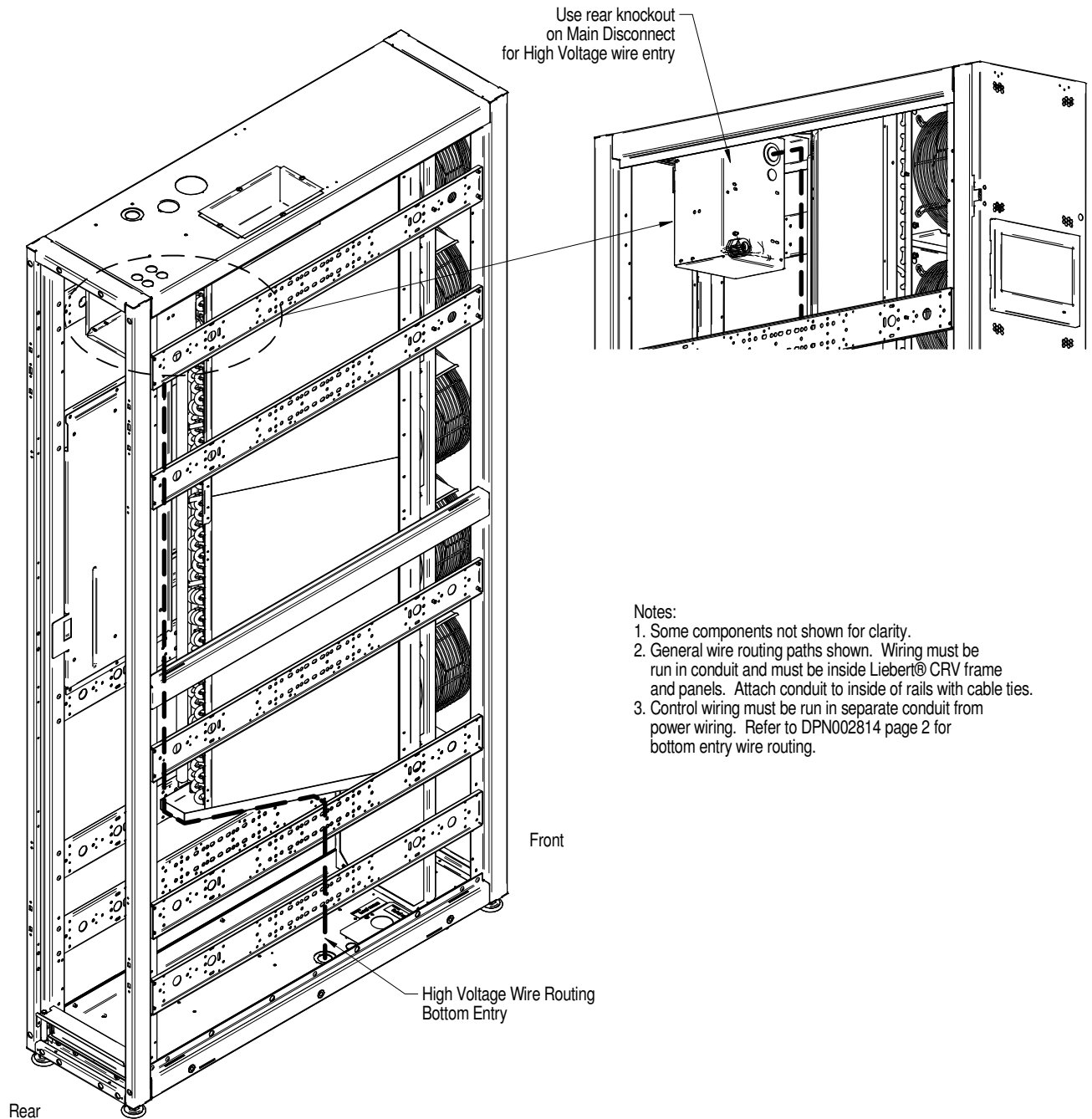

Notes:

1. Some components not shown for clarity.
2. General wire routing paths shown. Wiring must be run in conduit and must be inside Liebert® CRV frame and panels. Attach conduit to inside of rails with cable ties.
3. Control wiring must be run in separate conduit from power wiring. Refer to DPN002814 page 2 for bottom entry wire routing.

## POWER CABLE ROUTING BOTTOM ENTRY 300mm (12in.) CHILLED WATER MODELS

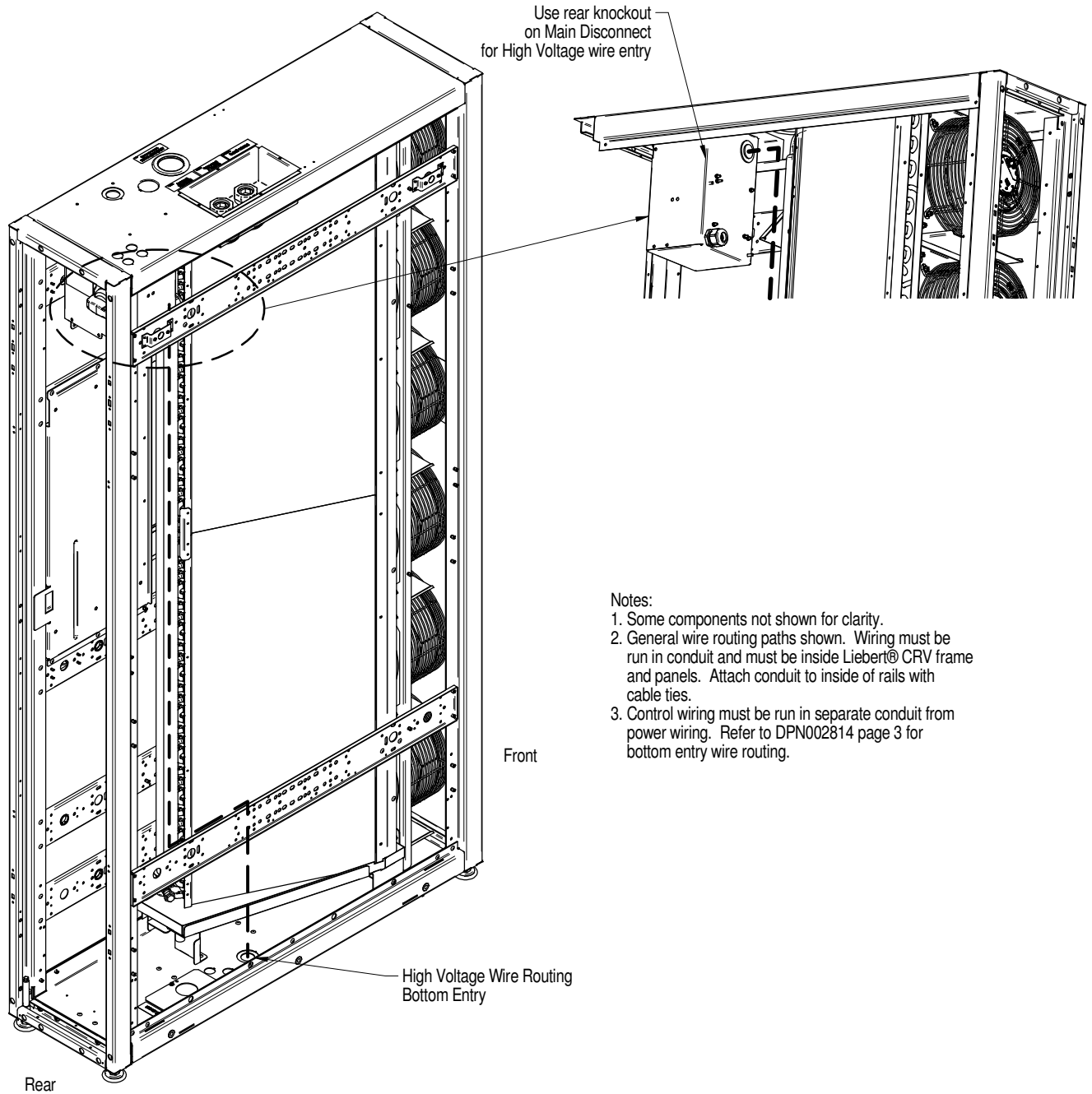

## LIEBERT® INTELLISLOT CABLE CONNECTION PATHS LIEBERT® INTELLISLOT WIRE ROUTING TOP OF UNIT 300mm (12in.) ALL MODELS

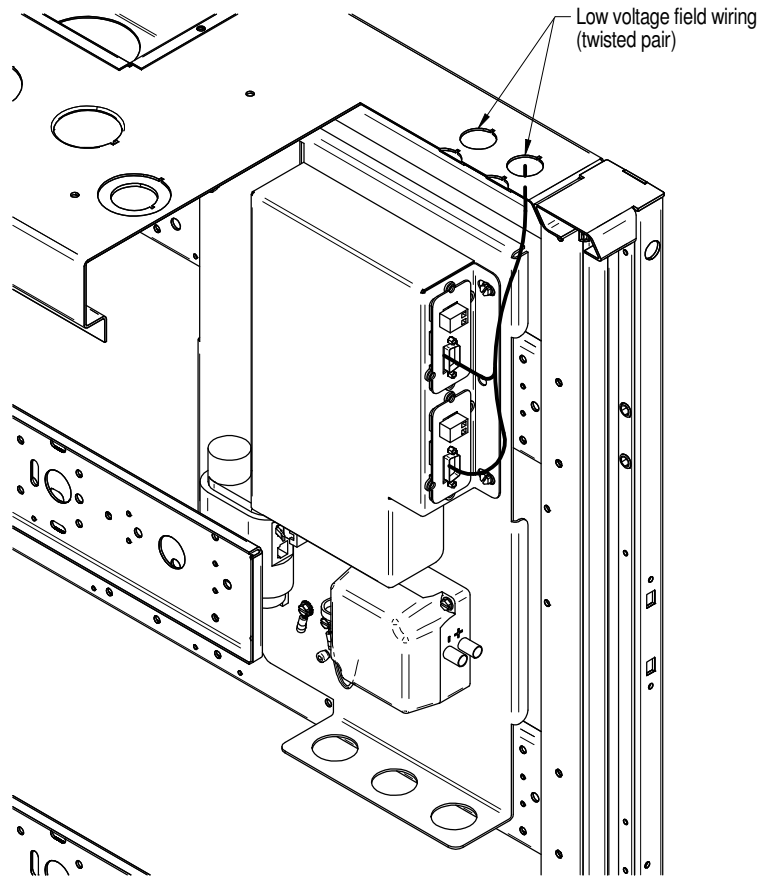
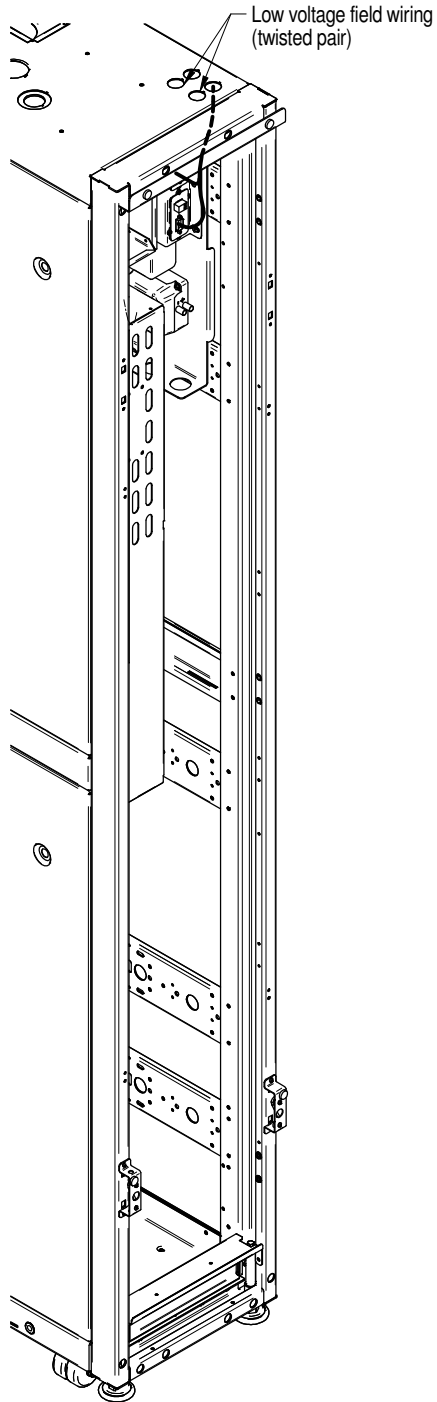

**LIEBERT® INTELLISLOT CABLE CONNECTION PATHS  
LIEBERT® INTELLISLOT WIRE ROUTING BOTTOM OF UNIT  
300mm (12in.) AIR, WATER/GLYCOL COOLED MODELS**

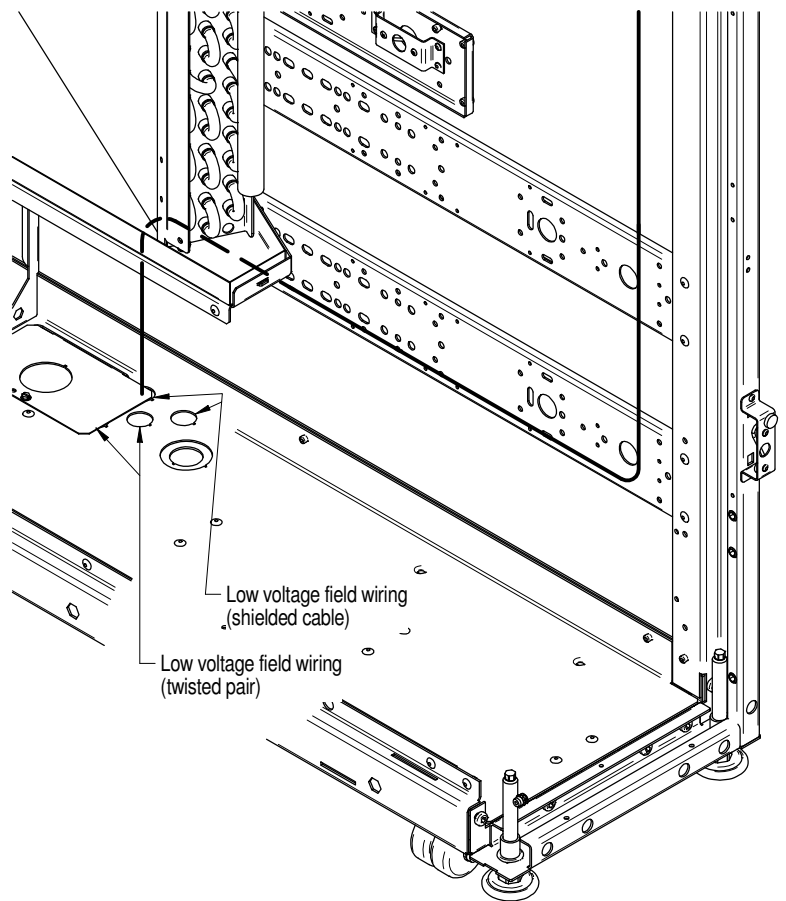
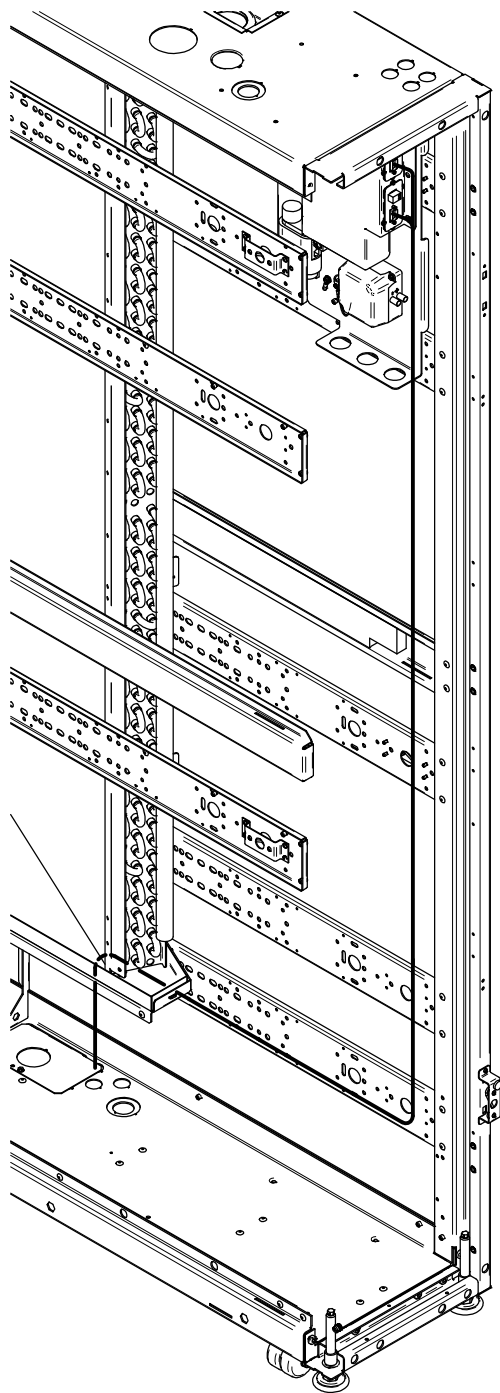

Secure tie the field wiring shielded cable to the rail. Route the shielded cable up toward the Intellislots and fasten to the side rails as needed.

## LIEBERT® INTELLISLOT CABLE CONNECTION PATHS LIEBERT® INTELLISLOT WIRE ROUTING BOTTOM OF UNIT 300mm (12in.) CHILLED WATER MODELS

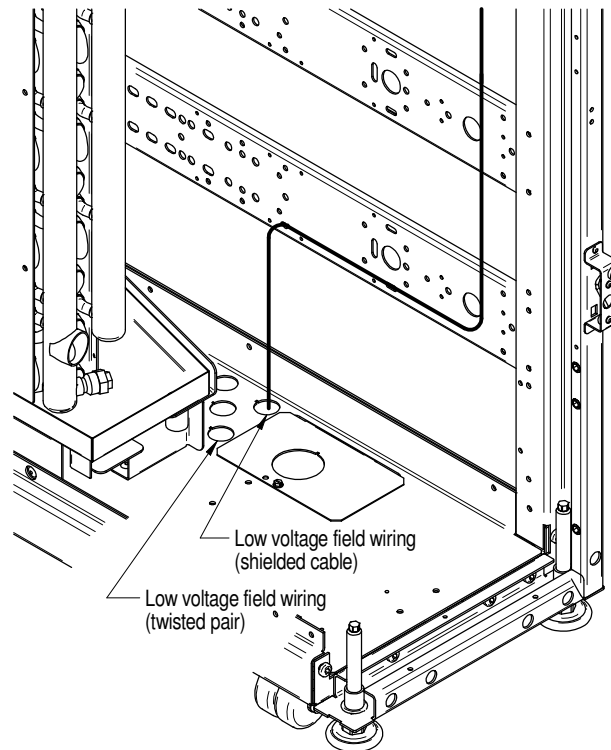
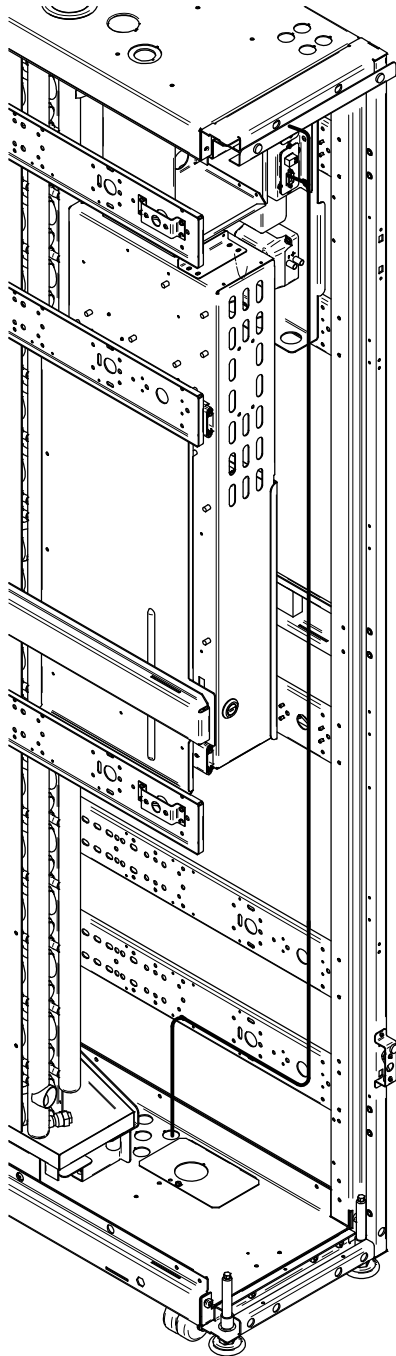

Secure the shielded cable to the rail. Route the shielded cable up toward the Intellislots and fasten to the side rails as needed.

## UNIT TO UNIT NETWORK CONNECTIONS WITHIN NETWORK GROUP (FOR 3+ UNITS)

### 300MM (12in.) UNITS

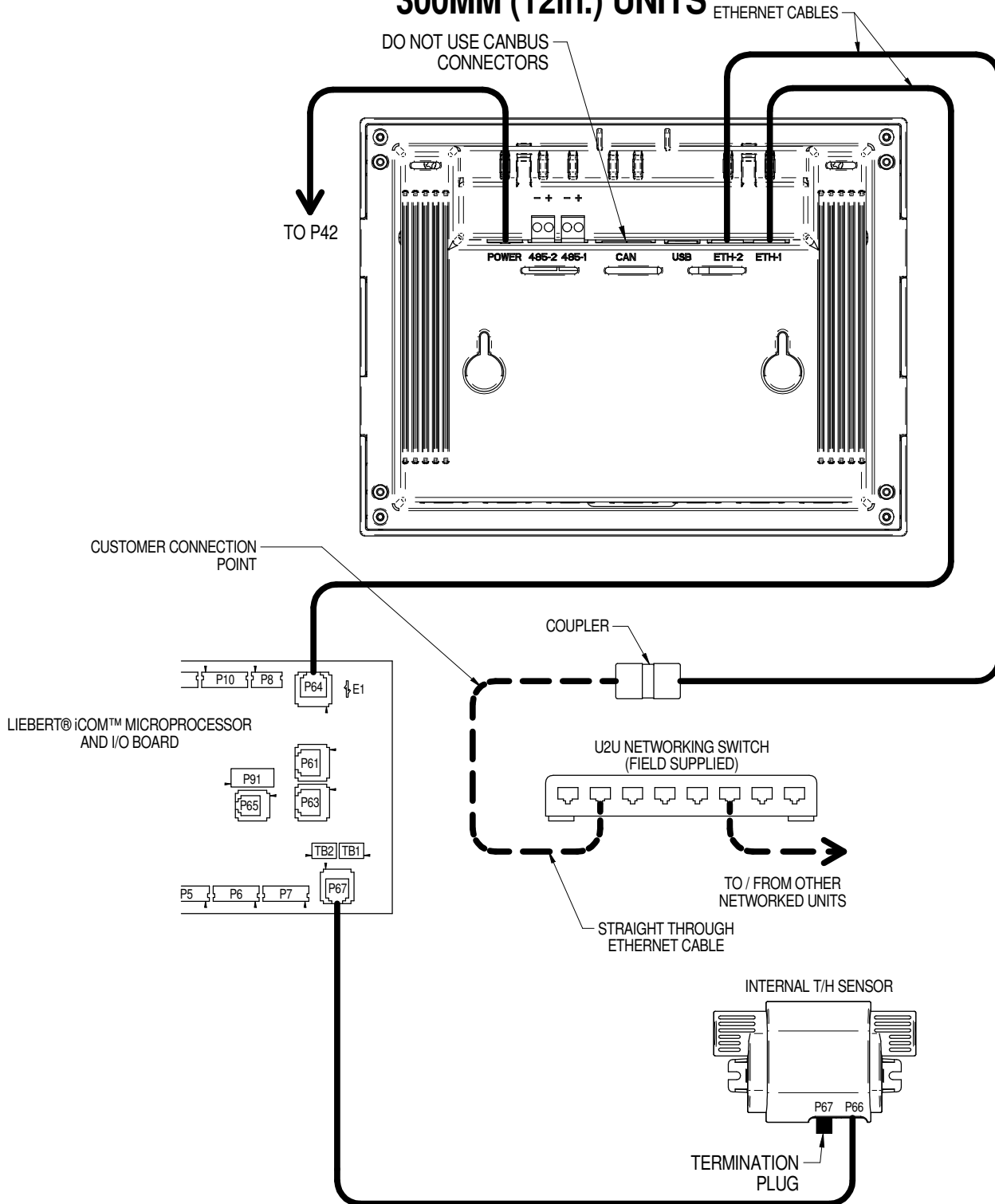



## UNIT TO UNIT NETWORK CONNECTIONS WITHIN NETWORK GROUP (FOR DUAL-UNITS) 300MM (12in.) UNITS

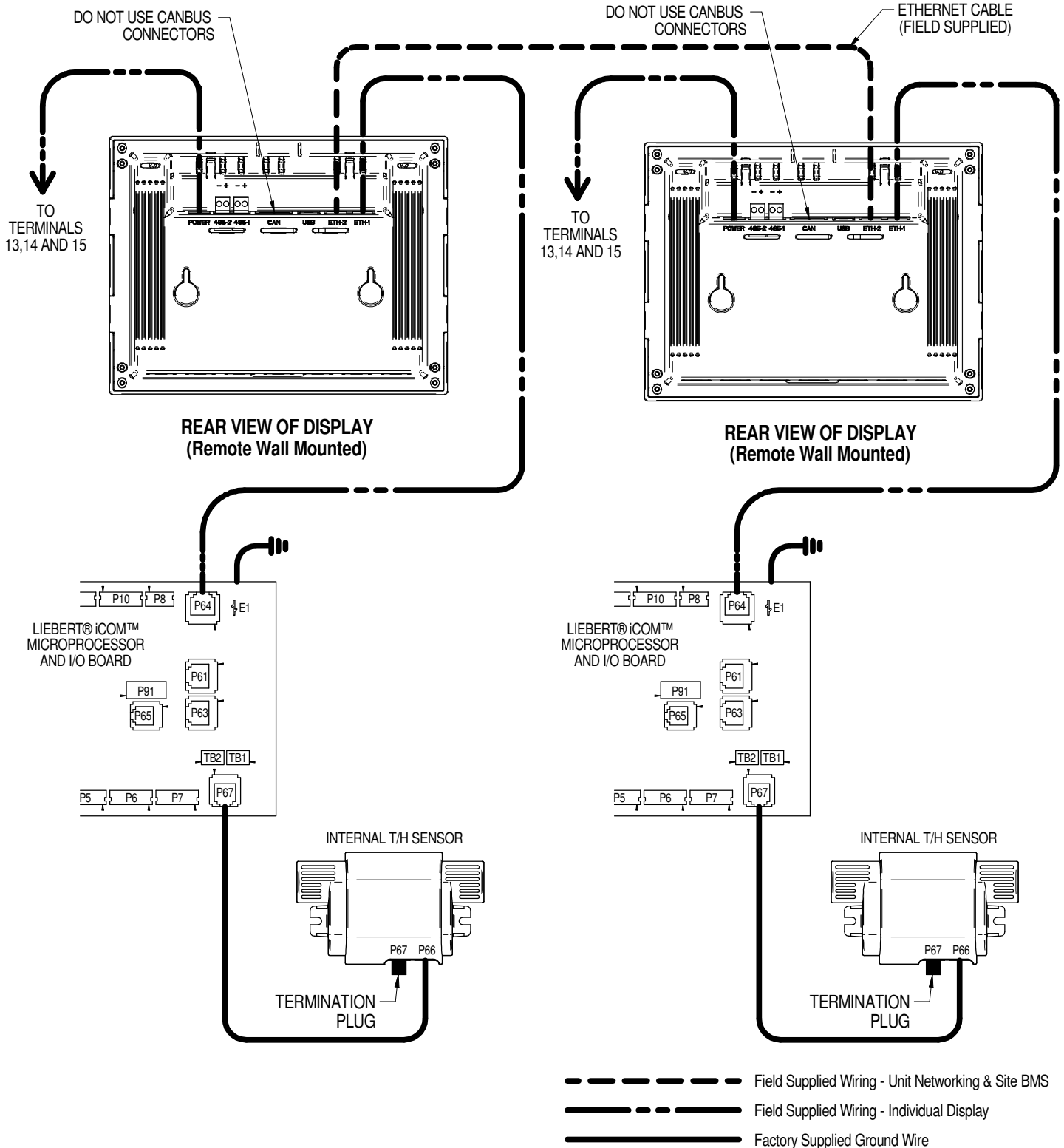

**CABINET & ANCHOR DIMENSIONAL DATA**  
**1 FAN (MCS028, MCM040, MCL055)**

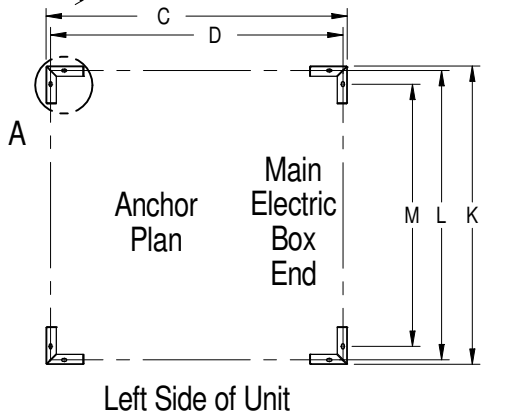
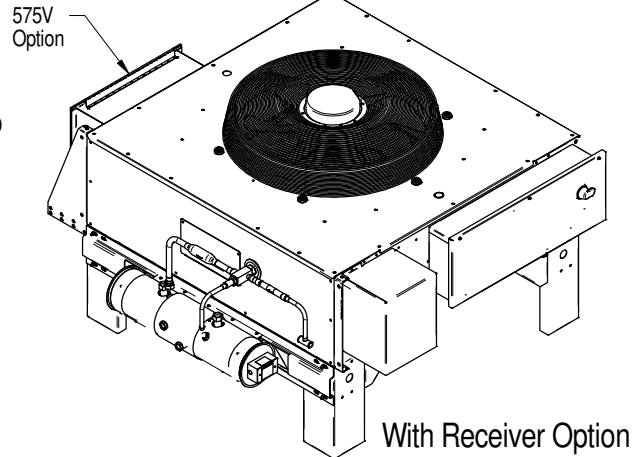
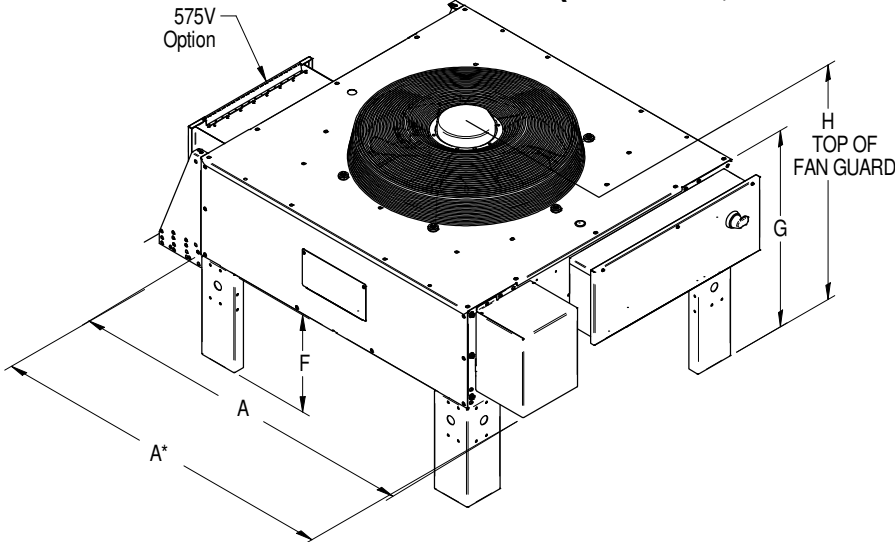

Left Side of Unit

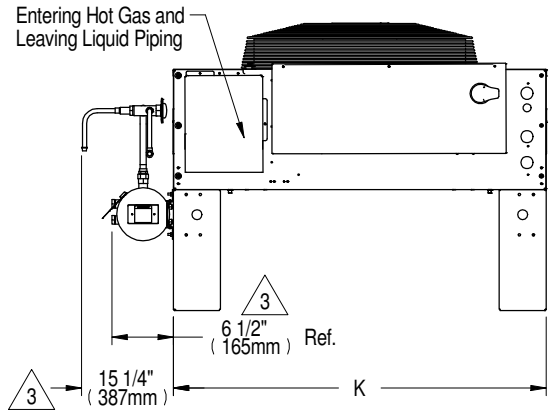

Front View (Liebert® Lee-Temp Shown)

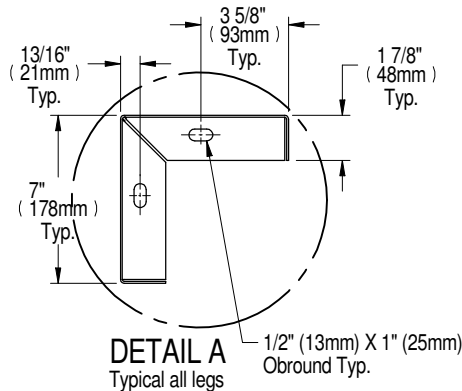

DETAIL A  
Typical all legs

MODEL NUMBER	F in. (mm) (LEG HEIGHT DIMENSIONS) <sup>2</sup>			
	18 (457)	36 (914)	48 (1219)	60 (1524)
MCS028				
MCM040				
DIM "G"	31-5/8 (803)	49-5/8 (1260)	61-5/8 (1565)	73-5/8 (1870)
DIM "H"	39-5/8 (1006)	57-5/8 (1464)	69-5/8 (1768)	81-5/8 (2073)
MCL055				
DIM "G"	35-7/8 (911)	53-7/8 (1368)	65-7/8 (1673)	77-7/8 (1978)
DIM "H"	43-5/8 (1108)	61-5/8 (1565)	73-5/8 (1870)	85-5/8 (2175)

Note:

- Vertiv recommends a clearance of 36" (915mm) on each side for proper operation and component access.
- <sup>2</sup> Cross Bracing required for legs longer than 18" (457.2mm). Quantity varies per model & options selected.
- <sup>3</sup> For Liebert® PDX w/EEV systems & unheated refrigerant receivers, 6-1/2" (165mm) is 9-1/4" (235mm) and 15-1/4" (387) is not applicable.

MODEL NUMBER	A in (mm)	A* in (mm) (575V ONLY)	C in (mm)	D in (mm)	K in (mm)	L in (mm)	M in (mm)
MCS028	50-5/8 (1287)	58-7/8 (1495)	44-1/8 (1120)	42-1/2 (1080)	42-1/2 (1080)	40-7/8 (1038)	35-7/8 (910)
MCM040	57-3/16 (1453)	65-3/8 (1661)	48 (1219)	46-5/16 (1177)	46 (1168)	44-3/8 (1127)	39-5/16 (999)
MCL055	68 (1727)	77 (1956)	56 (1422)	54-3/8 (1381)	55-1/2 (1410)	53-7/8 (1368)	48-3/4 (1238)

## CABINET & ANCHOR DIMENSIONAL DATA 2 FAN (MCS056, MCM080, MCL110) DUAL CIRCUIT

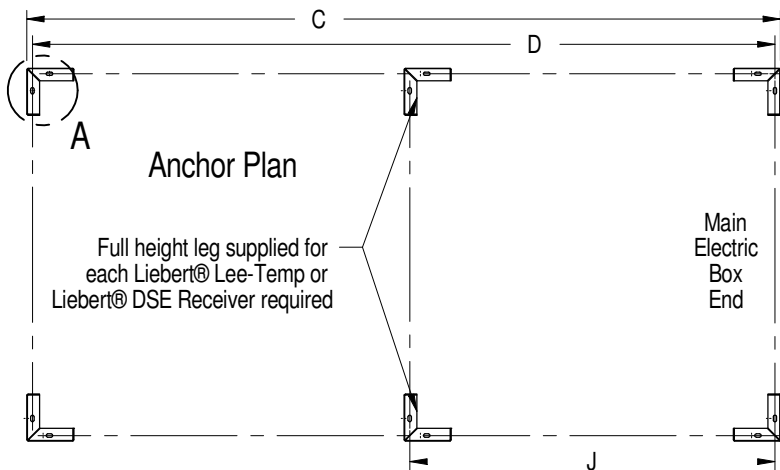
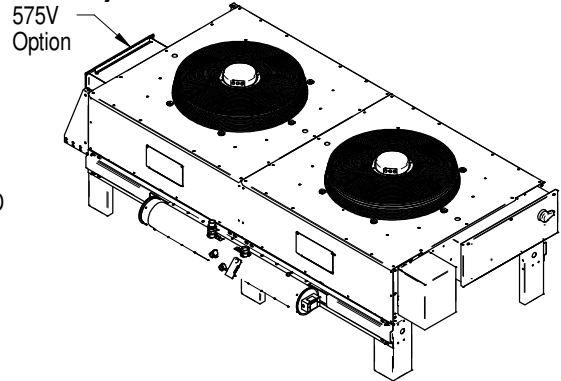
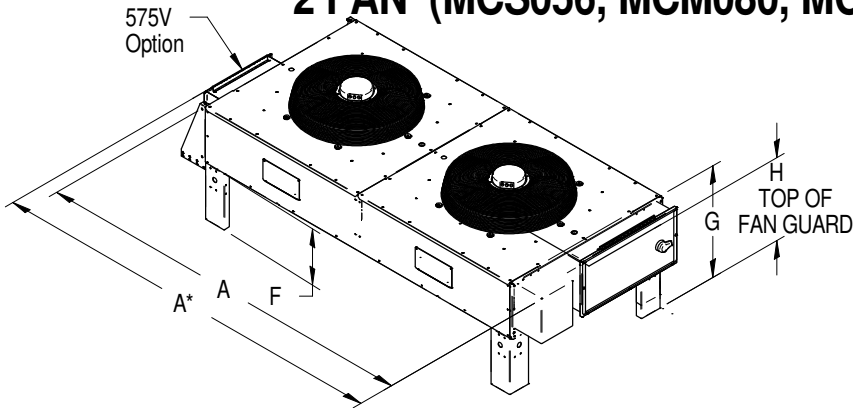

Liebert® Lee-Temp or Liebert® DSE Receiver (optional)

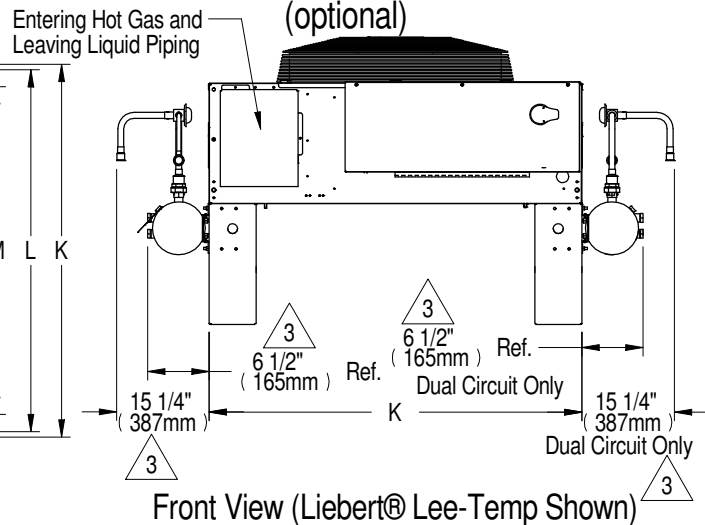

Left Side of Unit Liebert® Lee-Temp or Liebert® DSE Only with optional receiver

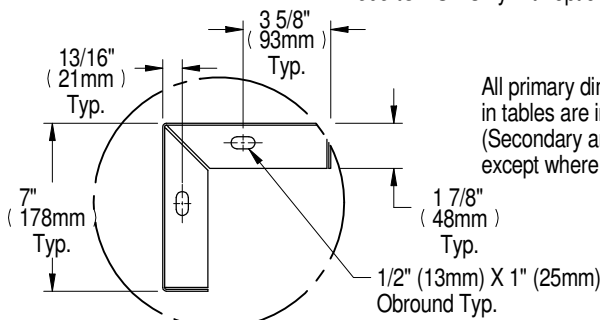

DETAIL A  
Typical All Legs

All primary dimensions in tables are in inches (Secondary are in mm) except where specified

MODEL NUMBER	F 2 (LEG HEIGHT DIMENSIONS)			
	18 (457)	36 (914)	48 (1219)	60 (1524)
MCS056	18 (457)	36 (914)	48 (1219)	60 (1524)
MCM080	31-5/8 (803)	49-5/8 (1260)	61-5/8 (1565)	73-5/8 (1870)
MCL110	35-7/8 (911)	53-7/8 (1368)	65-7/8 (1673)	77-7/8 (1978)
	43-5/8 (1108)	61-5/8 (1565)	73-5/8 (1870)	85-5/8 (2175)

Note:  
1. Vertiv recommends a clearance of 36" (915mm) on each side for proper operation and component access.

2 Cross bracing required for legs longer than 18" (457mm). Quantity varies per model & options selected.

3 For Liebert® DSE models with optional receiver, 6-1/2" (165mm) dimension is 9-1/4" (235mm) and 15-1/4" (387mm) dimension is not applicable.

MODEL NUMBER	A	A* (575V ONLY)	C	D	J Liebert® Lee-Temp or Liebert® DSE Receivers optional	K	L	M
MCS056	94-7/8 (2411)	103-1/8 (2619)	88-3/8 (2245)	86-3/4 (2203)	42-1/2 (1079)	42-1/2 (1080)	40-7/8 (1038)	35-7/8 (910)
MCM080	105-1/4 (2674)	113-7/16 (2882)	96-1/16 (2440)	94-7/16 (2398)	46-5/16 (1177)	46 (1168)	44-3/8 (1127)	39-5/16 (999)
MCL110	124-1/8 (3152)	133-1/8 (3381)	112-1/8 (2848)	110-1/2 (2806)	54-3/8 (1381)	55-1/2 (1410)	53-7/8 (1368)	48-3/4 (1238)

## PIPING DIMENSIONAL DATA SINGLE CIRCUIT 1 FAN, 2 FAN, 3 FAN & 4 FAN UNITS

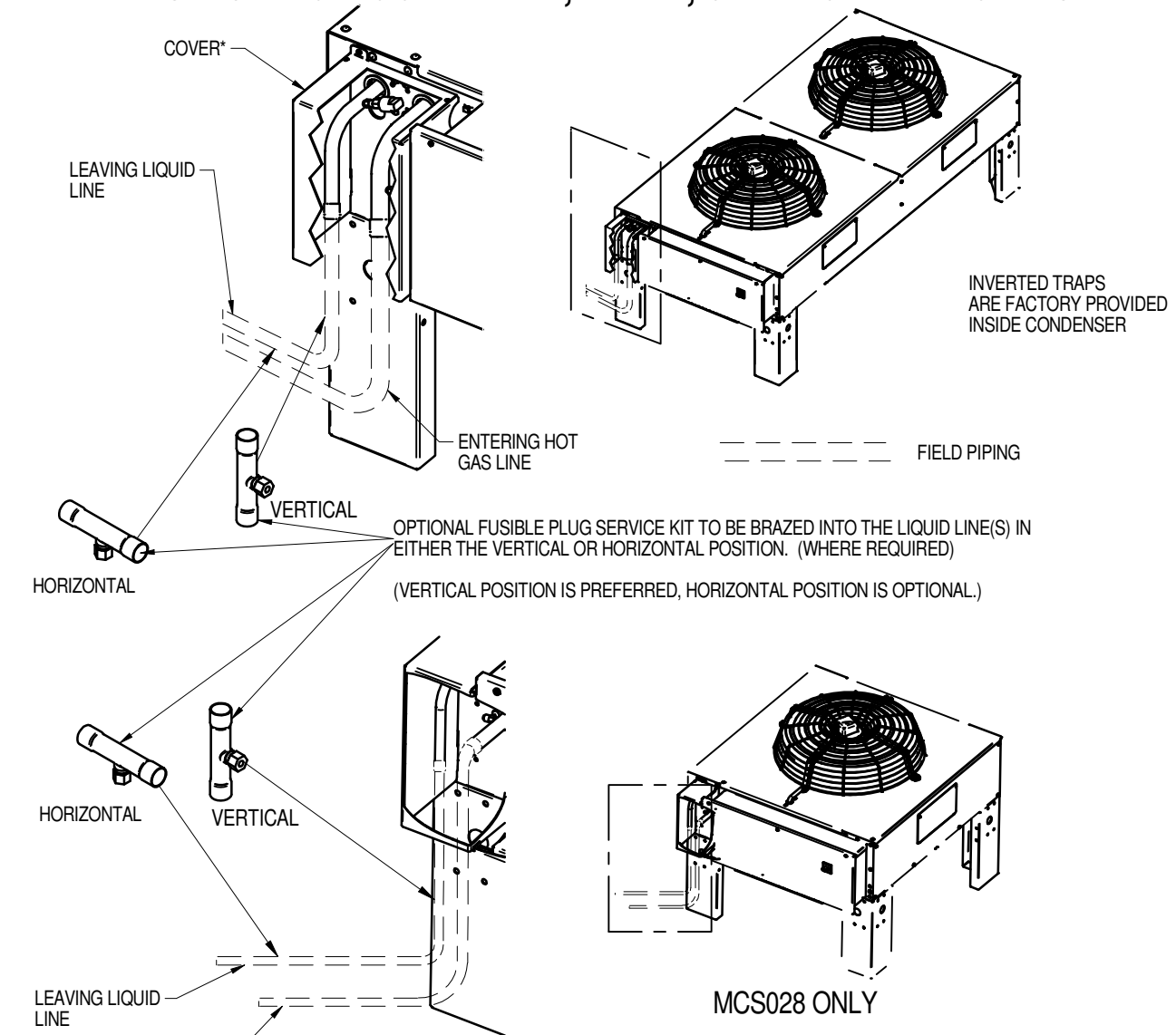

MODEL NO.	NUMBER OF FANS	CONDENSER CIRCUITS	CONNECTION SIZES, OD, IN	
			HOT GAS LINE	LIQUID LINE
MCS 028	1	1	7/8	5/8
MCM 040	1	1	7/8	5/8
MCM 080	2	1	1-1/8	7/8
MCL 055	1	1	1-1/8	7/8
MCL 110	2	1	1-3/8	1-1/8
MCL 165	3	1	1-3/8	1-1/8
MCL 220	4	1	1-5/8	1-3/8

\* SHIPPING COVER IS NOT NECESSARY FOR PROPER CONDENSER OPERATION AND MAY BE RECYCLED IF FIELD PIPING INTERFERES WITH PROPER REATTACHMENT.

## PIPING LOCATIONS SINGLE CIRCUIT WITH LIEBERT® LEE-TEMP

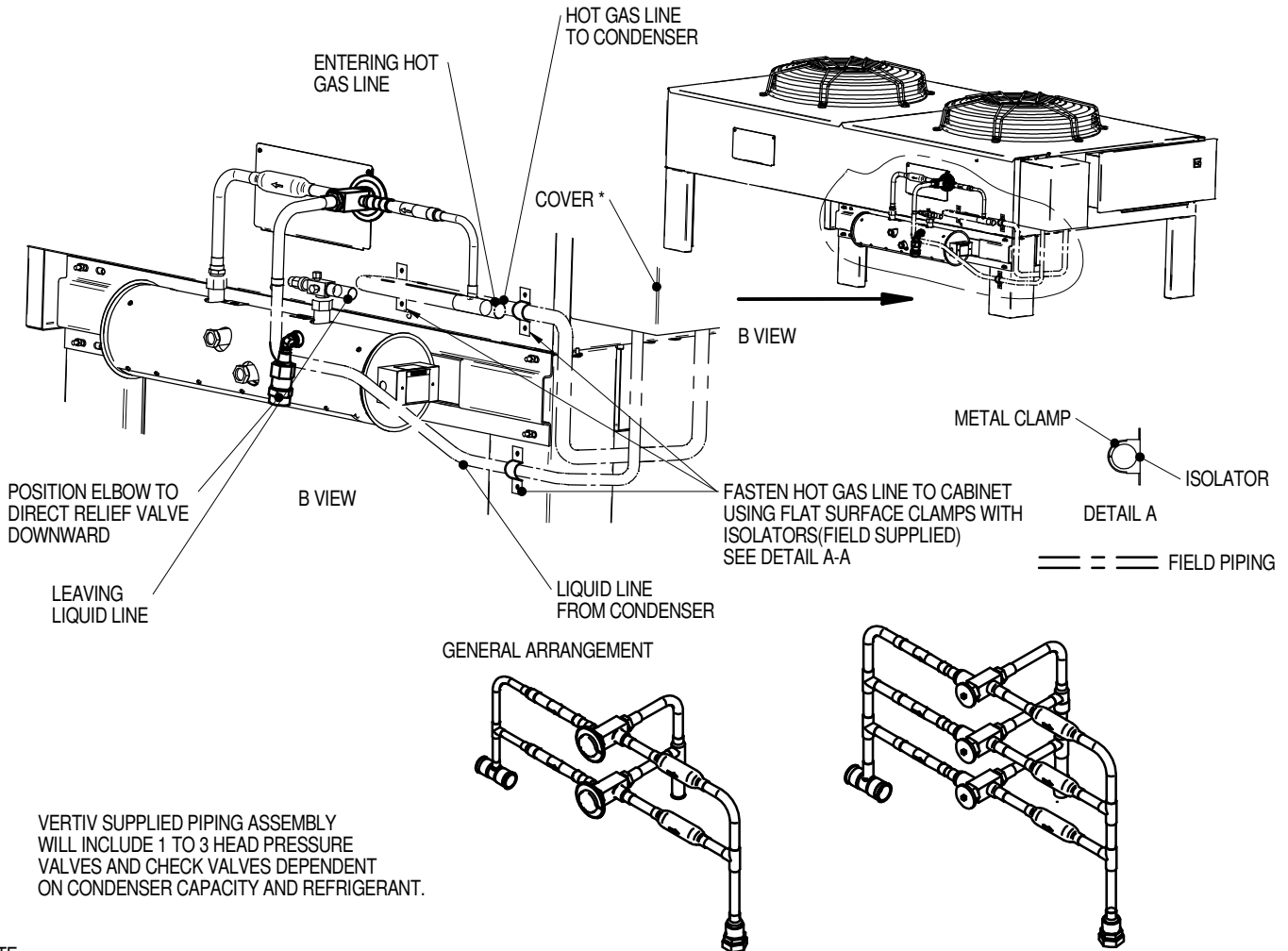

VERTIV SUPPLIED PIPING ASSEMBLY WILL INCLUDE 1 TO 3 HEAD PRESSURE VALVES AND CHECK VALVES DEPENDENT ON CONDENSER CAPACITY AND REFRIGERANT.

**NOTE:**

1. THE FOLLOWING MATERIALS ARE SUPPLIED BY VERTIV, SHIPPED LOOSE FOR EACH CIRCUIT AND FOR FIELD INSTALLATION: INSULATED LIEBERT® LEE-TEMP RECEIVER TANK WITH ELECTRIC HEATER PADS AND SIGHT GLASSES, PIPING ASSEMBLY WITH HEAD PRESSURE CONTROL VALVE AND CHECK VALVE, ROTO-LOCK VALVE AND PRESSURE RELIEF VALVE. ALL OTHER PIPING AND ELECTRICAL WIRING TO BE SUPPLIED AND INSTALLED BY OTHERS. ADDITIONAL CONDENSER LEG PER CIRCUIT WHEN REQUIRED, SHIPS WITH THE CONDENSER.

CONDENSER PIPING CONNECTION SIZES						
CONDENSER CONNECTIONS (ODS-INCHES)				LIEBERT® LEE-TEMP CONNECTIONS		
MODEL NO.	CONDENSER CIRCUITS	HOT GAS	LIQUID	HOT GAS TEE (IDS-INCHES)	LIQ TO L-T VALVE (ODS-INCHES)	RECEIVER OUT ROTO LOCK (IDS-INCHES)
MCS028	1	7/8	5/8	7/8	5/8	5/8
MCM040						
MCM080		1-1/8	7/8	1-1/8	7/8	1-1/8
MCL055						7/8
MCL110		1-3/8	1-1/8	1-3/8	1-1/8	1-1/8
MCL165						
MCL220		1-5/8	1-3/8	1-5/8	1-3/8	1-3/8

\* SHIPPING COVER IS NOT NECESSARY FOR PROPER CONDENSER OPERATION AND MAY BE RECYCLED IF FIELD PIPING INTERFERES WITH PROPER REATTACHMENT.

## ELECTRICAL FIELD CONNECTIONS PREMIUM EFFICIENCY CONTROL

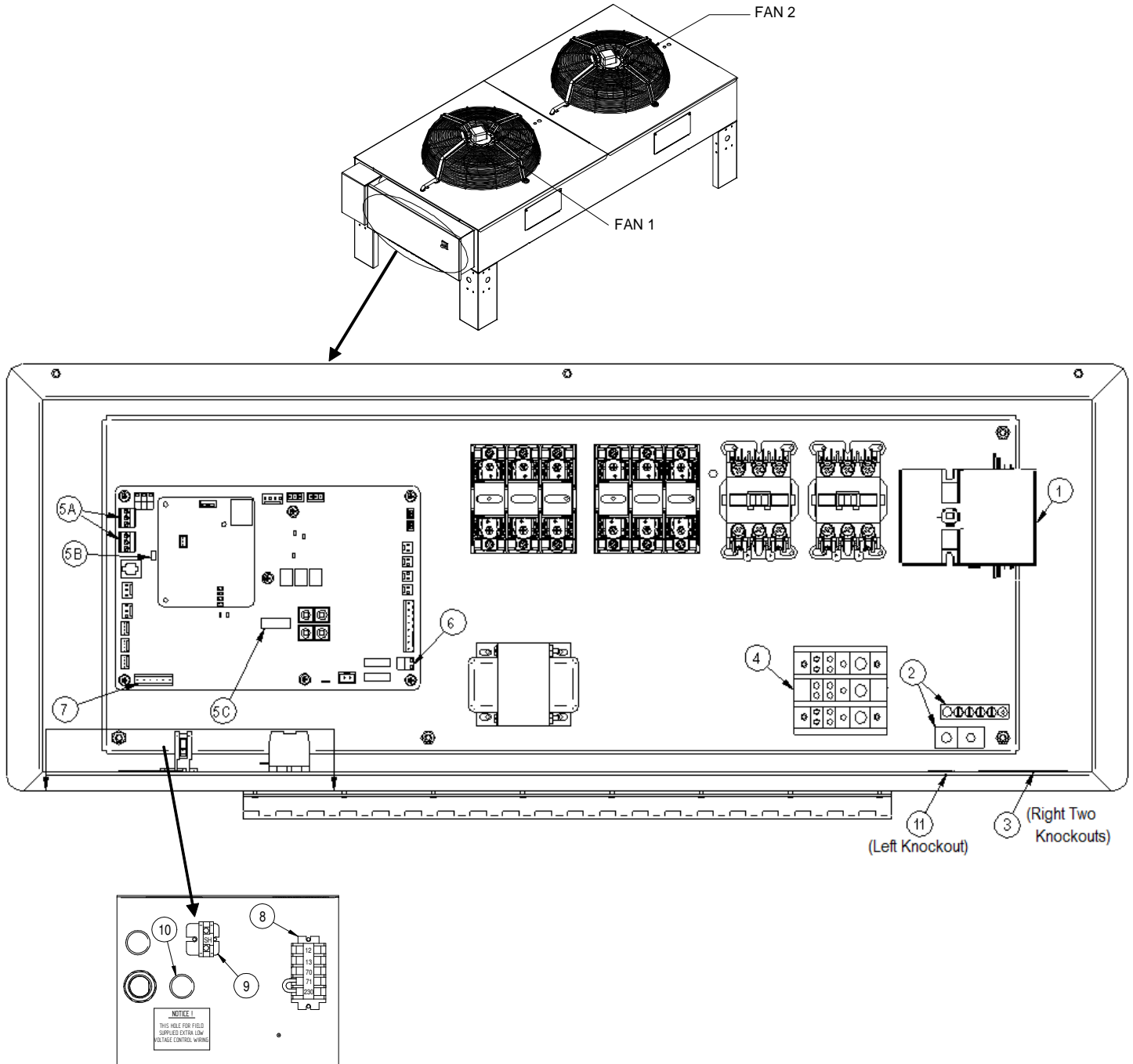

### KEY ELECTRICAL DETAILS:

- 1) **Three phase electrical service** – Terminals are on top of disconnect switch for one and two fan units. Terminals are on bottom of disconnect switch for three and four fan units. Three phase service not by Vertiv. See note 5.
- 2) **Earth ground** – Field lug terminal for earth ground connection. Ground terminal strip for fan motor ground connection.
- 3) **Primary high voltage entrance** – Two 7/8" (22.2mm) diameter knockouts located at the bottom of the enclosure.
- 4) **SPD field connection terminals** – High voltage surge protective device (SPD) terminals. SPD is an optional device.



## ELECTRICAL FIELD CONNECTIONS PREMIUM EFFICIENCY CONTROL

- 5) **CANbus terminal connections** – Field terminals for CANbus cable connection.
- 5A is the CANbus connectors.
    - TB49-1 is the input terminal for CANbus high.
    - TB49-3 is the input terminal for CANbus low.
    - TB50-1 is output terminal for CANbus high.
    - TB50-3 is the output terminal for CANbus low.
    - Each CANbus cable shield is connected to terminal “SH”, item 9.
  - 5B is the “END OF LINE” jumper.
  - 5C is the CANbus “DEVICE ADDRESS DIP SWITCH”. CANbus cable not by Vertiv. See Note 2. (below)
- 6) **Remote unit shutdown** – Replace existing jumper between terminals TB38-1 and TB38-2 with field supplied normally closed switch having a minimum 75VA 24VAC rating. Use field supplied Class 1 wiring. (This is an optional feature that may be owner specified.)
- 7) **Alarm terminal connections** –
- a. Common Alarm Relay indicates when any type of alarm occurs. TB74-1 is common, TB74-2 is normally open, and TB74-3 is normally closed. 1 Amp 24VAC is the maximum load. Use Class 1 field supplied wiring.
  - b. Shutdown Alarm Relay indicates when condenser loses power, or when a critical alarm has occurred that shuts down the condenser unit. TB74-4 is common, TB74-5 is normally open, and TB74-6 is normally closed. 1 Amp 24VAC is the maximum load. Use Class 1 field supplied wiring.
- 8) **Indoor unit interlock and SPD alarm terminals** –
- a. On any call for compressor operation, normally open contact is closed across terminals 70 and 71 for Circuit 1, and normally open contact is closed across terminals 70 and 230 for Circuit 2 from indoor room unit.
  - b. During SPD alarm, normally open contact is closed across terminals 12 & 13. SPD is an optional device.
- 9) **CANbus shield terminal** – Terminal for field shield connection of the CANbus field supplied cables. The shield of CANbus field supplied cables must not be connected to ground at the condenser.
- 10) **Primary low voltage entrance** – One 7/8” (22.2mm) diameter knockout that is free for customer low voltage wiring.
- 11) **SPD entrance** – One 7/8” (22.2mm) diameter knockout hole located at the bottom of the enclosure. High voltage surge protective device (SPD) is optional.

### NOTES:

1. Refer to specification sheet for unit voltage rating, full load amp, and wire size amp ratings.
2. The CANbus wiring is field supplied and must be:
  - Braided shield or foil shield with drain wire
  - Shield must be wired to ground at indoor unit
  - 22-18AWG stranded tinned copper
  - Twisted pair (minimum 4 twists per foot)
  - Low Capacitance (15pF/FT or less)
  - Must be rated to meet local codes and conditions
  - EXAMPLES BELDEN 89207 (PLENUM RATED), OR ALPHA WIRE 6454 CATEGORY 5, 5E, OR HIGHER
3. Do not run in same conduit, raceway, or chase as high voltage wiring.
4. For CANbus network lengths greater than 450FT (137M) call Factory.



# LIEBERT® MC

---

## ELECTRICAL FIELD CONNECTIONS PREMIUM EFFICIENCY CONTROL

5. All wiring must be sized and selected for insulation case per NEC and other local codes.
6. Do not bend cables to less than four times the diameter of the cable.
7. Do not deform cables when securing in bundles or when hanging them.
8. Avoid running the cables by devices that may introduce noise, such as machines, fluorescent lights, and electronics.
9. Avoid stretching cables.
10. The electrically commutated (EC) motors included in the Liebert® MC are suitable for connection to power supplies with a solidly grounded neutral or high resistance to ground or corner ground.
  - a. Acceptable power supplies for 208 to 575V nominal units:
    - 208V wye with solidly grounded neutral and 120V line to ground;
    - 380V wye with solidly grounded neutral and 220V line to ground;
    - 480V wye with solidly grounded neutral and 277V line to ground;
    - 575V wye with solidly grounded neutral and 332V line to ground (uses step-down transformer);
    - Wye with high resistance (or impedance) ground;
    - Delta with corner ground
  - b. Unacceptable power supplies for 208V to 575V nominal units:
    - Delta without ground or with floating ground;
    - Delta with grounded center tap.



## ELECTRICAL FIELD CONNECTIONS PREMIUM EFFICIENCY CONTROL WITH LIEBERT® LEE-TEMP

### Electrical Connections for Liebert® Lee-Temp Receiver

Liebert® Lee-Temp receiver tank (1 per circuit).

NOTE: Heater pad voltage available for  
120V/1 phase/60 Hz or 230V/1 phase/60Hz  
150 or 300 Watt, varies by condenser.

Electrical connection box with cover.  
(Cover removed for clarity.)

Electrical service connection. Pigtails in electric handy box  
are factory wired to Liebert® Lee-Temp heater pads for field  
connection of separate continuous electric source, wire not by Vertiv.

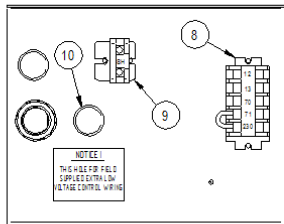
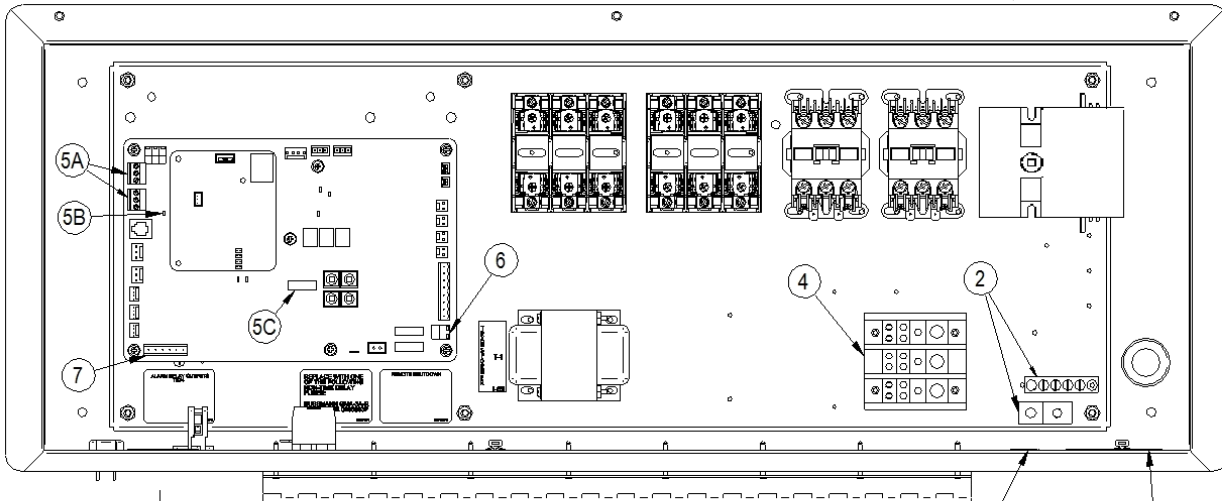
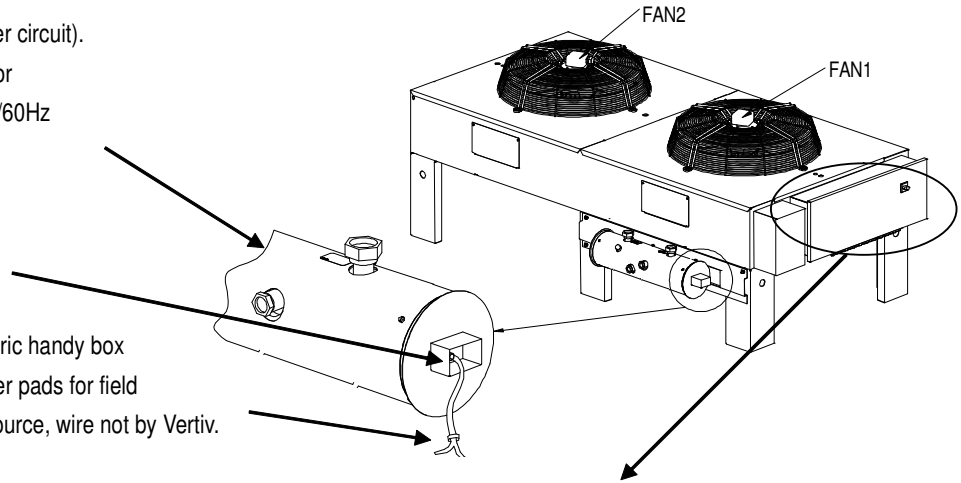

(LEFT KNOCKOUT) (RIGHT TWO KNOCKOUTS)

### KEY ELECTRICAL DETAILS:

- 1) **Three phase electrical service** – Terminals are on top of disconnect switch for one and two fan units. Terminals are on bottom of disconnect switch for three and four fan units. Three phase service not by Vertiv. See Note 5 (below).
- 2) **Earth ground** – Field lug terminal for earth ground connection. Ground terminal strip for fan motor ground connection.
- 3) **Primary high voltage entrance** – Two 7/8" (22.2mm) diameter knockouts located at the bottom of the enclosure.
- 4) **SPD field connection terminals** – High voltage surge protective device (SPD) terminals. SPD is an optional device.

---

## **ELECTRICAL FIELD CONNECTIONS**

### **PREMIUM EFFICIENCY CONTROL WITH LIEBERT® LEE-TEMP**

- 5) **CANbus terminal connections** – Field terminals for CANbus cable connection.
- 5A is the CANbus connectors.
    - TB49-1 is the input terminal for CANbus high.
    - TB49-3 is the input terminal for CANbus low.
    - TB50-1 is output terminal for CANbus high.
    - TB50-3 is the output terminal for CANbus low.
    - Each CANbus cable shield is connected to terminal “SH”, item 9.
  - 5B is the “END OF LINE” jumper.
  - 5C is the CANbus “DEVICE ADDRESS DIP SWITCH”. CANbus cable not by Vertiv. See Note 2 (below).
- 6) **Remote unit shutdown** – Replace exiting jumper between terminals TB38-1 and TB38-2 with field supplied normally closed switch having a minimum 75VA 24VAC rating. Use field supplied Class 1 wiring. (This is an optional feature that may be owner specified.)
- 7) **Alarm terminal connections** –
- a. Common Alarm Relay indicates when any type of alarm occurs. TB74-1 is common, TB74-2 is normally open, and TB74-3 is normally closed. 1 Amp 24VAC is the maximum load. Use Class 1 field supplied wiring.
  - b. Shutdown Alarm Relay indicates when condenser loses power, or when a critical alarm has occurred that shuts down the condenser unit. TB74-4 is common, TB74-5 is normally open, and TB74-6 is normally closed. 1 Amp 24VAC is the maximum load. Use Class 1 field supplied wiring.
- 8) **Indoor unit interlock and SPD alarm terminals** –
- a. On any call for compressor operation, normally open contact is closed across terminals 70 & 71 for Circuit 1, and normally open contact is closed across terminals 70 & 230 for Circuit 2 from indoor room unit.
  - b. During SPD alarm, normally open contact is closed across terminals 12 & 13. SPD is an optional device.
- 9) **CANbus shield terminal** – Terminal for field connection of the CANbus field supplied cables. Shield of CANbus field supplied cables must not be connected to ground.
- 10) **Primary low voltage entrance** – One 7/8” (22.2mm) diameter knockout that is free for customer low voltage wiring.
- 11) **SPD entrance** – One 7/8” (22.2mm) diameter knockout hole located at the bottom of the enclosure. High voltage surge protective device (SPD) is optional.

**NOTES:**

1. Refer to specification sheet for unit voltage rating, full load amp, and wire size amp ratings.
2. The CANbus wiring is field supplied and must be:
  - Braided shield or foil shield with drain wire
  - Shield must be wired to ground at indoor unit
  - 22-18AWG stranded tinned copper
  - Twisted pair (minimum 4 twists per foot)
  - Low Capacitance (15pF/FT or less)
  - Must be rated to meet local codes and conditions
  - EXAMPLES BELDEN 89207 (PLENUM RATED), OR ALPHA WIRE 6454 CATEGORY 5, 5E, OR HIGHER
3. Do not run in same conduit, raceway, or chase as high voltage wiring.
4. For CANbus network lengths greater than 450FT (137M) call Factory.



# LIEBERT® MC

---

## ELECTRICAL FIELD CONNECTIONS

### PREMIUM EFFICIENCY CONTROL WITH LIEBERT® LEE-TEMP

5. All wiring must be sized and selected for insulation case per NEC and other local codes.
6. Do not bend cables to less than four times the diameter of the cable.
7. Do not deform cables when securing in bundles or when hanging them.
8. Avoid running the cables by devices that may introduce noise, such as machines, fluorescent lights, and electronics.
9. Avoid stretching cables.
10. The electrically commutated (EC) motors included in the Liebert® MC are suitable for connection to power supplies with a solidly grounded neutral or high resistance to ground or corner ground.
  - A. Acceptable power supplies for 208 to 575V nominal units:
    - 208V wye with solidly grounded neutral and 120V line to ground;
    - 380V wye with solidly grounded neutral and 220V line to ground;
    - 480V wye with solidly grounded neutral and 277V line to ground;
    - 575V wye with solidly grounded neutral and 332V line to ground (uses step-down transformer);
    - Wye with high resistance (or impedance) ground;
    - Delta with corner ground
  - B. Unacceptable power supplies for 208V to 575V nominal units:
    - Delta without ground or with floating ground;
    - Delta with grounded center tap.

## CANbus & INTERLOCK CONNECTIONS BETWEEN 600mm (24in.) UNIT & LIEBERT® MC (PREMIUM)

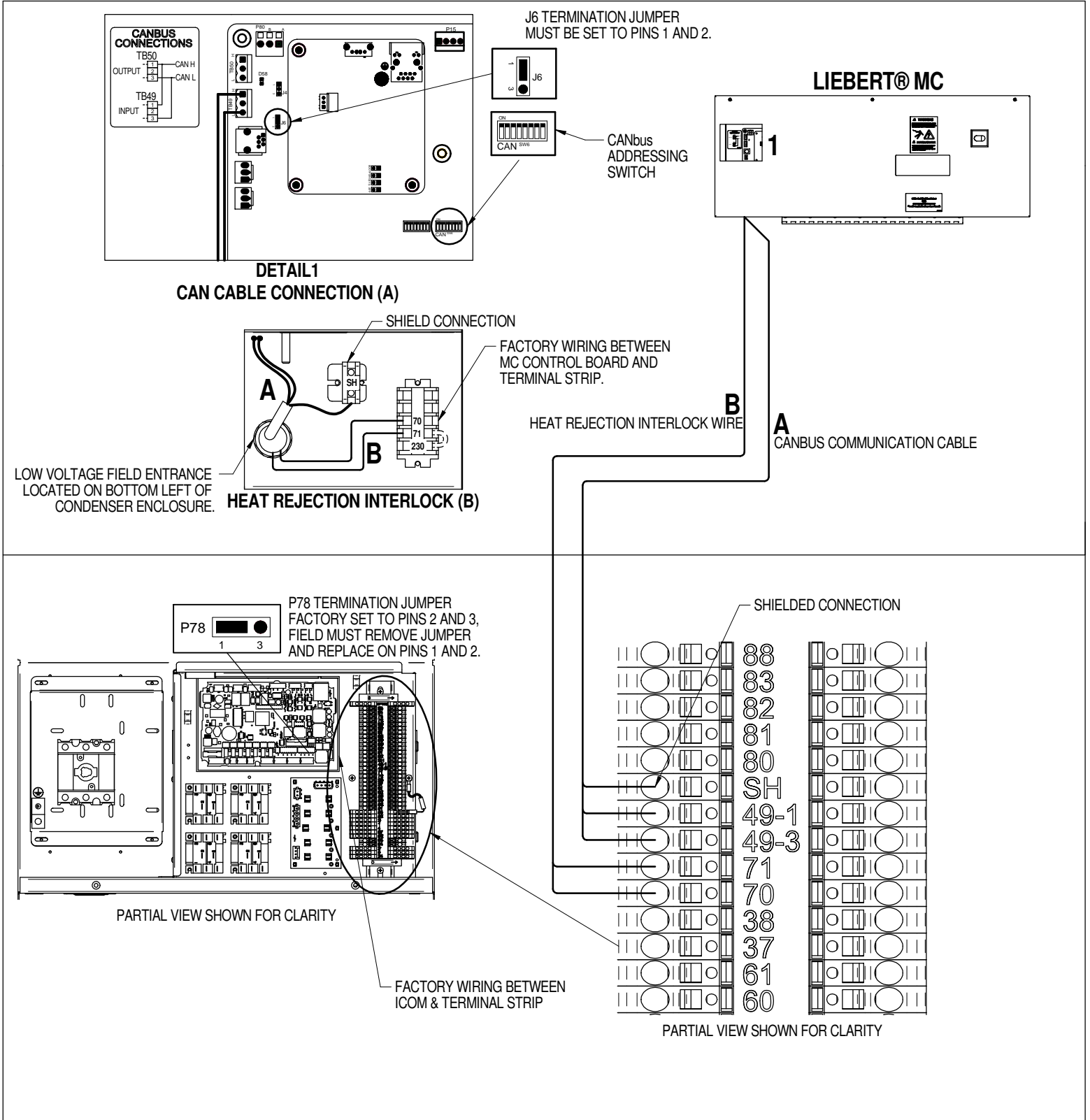



# LIEBERT® CRV

---

## CANbus & INTERLOCK CONNECTIONS BETWEEN 600mm (24in.) UNIT & LIEBERT® MC (PREMIUM)

### COMPONENT NOTES:

1. COMPONENT APPEARANCE, ORIENTATION, AND POSITION MAY VARY  
TERMINAL NAMES AND CALLOUTS REMAIN CONSTANT.
2. ALL CIRCUITS TO THESE CONNECTION POINTS ARE CLASS 2.

### CAN & CABLE NOTES (A):

1. CABLE MUST HAVE THE FOLLOWING SPECIFICATIONS:
  - BRAIDED SHIELD OR FOIL SHIELD WITH DRAIN WIRE
  - SHIELD MUST BE WIRED TO GROUND AT INDOOR UNIT
  - 22-18AWG STRANDED TINNED COPPER
  - TWISTED PAIR (MINIMUM 4 TWISTS PER FOOT)
  - LOW CAPACITANCE (15pF/FT OR LESS)
  - MUST BE RATED TO MEET LOCAL CODES AND CONDITIONS.
  - EXAMPLES BELDEN 89207 (PLENUM RATED), OR ALPHA WIRE 6454 CATEGORY 5, 5E, OR HIGHER.
2. DO NOT RUN IN SAME CONDUIT, RACEWAY, OR CHASE AS HIGH VOLTAGE WIRING.
3. FOR CANBUS NETWORK LENGTHS GREATER THAN 450FT(137M), CONTACT FACTORY.

### INTERLOCK WIRE NOTES (B):

1. FIELD SUPPLIED WIRE
  - 2 CONDUCTOR 18AWG OR GREATER
  - RATED 600V
2. RUN FIELD SUPPLIED WIRES BETWEEN THE INDOOR UNIT AND THE CONDENSER.

## CANbus & INTERLOCK CONNECTIONS BETWEEN 300mm (12in.) UNIT & LIEBERT® MC (PREMIUM)

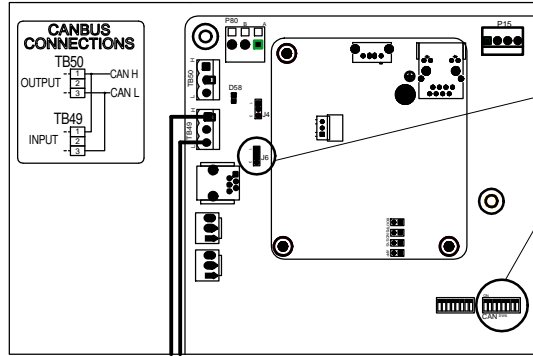

**DETAIL1  
CAN CABLE CONNECTION (A)**



J6 TERMINATION JUMPER  
MUST BE SET TO PINS 1 AND 2.



CANbus  
ADDRESSING  
SWITCH

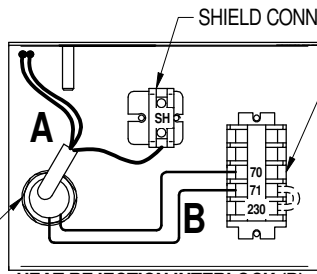
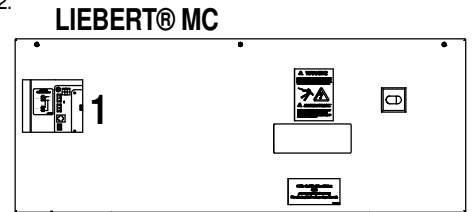

LOW VOLTAGE FIELD ENTRANCE  
LOCATED ON BOTTOM LEFT OF  
CONDENSER ENCLOSURE.

**HEAT REJECTION INTERLOCK (B)**

**A** CANbus CABLE CONNECTION

**B** HEAT REJECTION INTERLOCK

**COMPONENT NOTES:**

1. COMPONENT APPEARANCE, ORIENTATION AND POSITIONING MAY VARY. TERMINAL NAMES AND CALLOUTS REMAIN CONSTANT.
2. ALL CIRCUITS TO THESE CONNECTION POINTS ARE CLASS 2.

**CAN & CABLE NOTES (A):**

1. CABLE MUST HAVE THE FOLLOWING SPECIFICATIONS:
  - BRAIDED SHIELD OR FOIL SHIELD WITH DRAIN WIRE
  - SHIELD MUST BE WIRED TO GROUND AT INDOOR UNIT
  - 22-18AWG STRANDED TINNED COPPER
  - TWISTED PAIR (MINIMUM 4 TWISTS PER FOOT)
  - LOW CAPACITANCE (15pF/FT OR LESS)
  - MUST BE RATED TO MEET LOCAL CODES AND CONDITIONS.
  - EXAMPLES BELDEN 89207 (PLENUM RATED), OR ALPHA WIRE 6454 CATEGORY 5, 5E, OR HIGHER.
2. DO NOT RUN IN SAME CONDUIT, RACEWAY, OR CHASE AS HIGH VOLTAGE WIRING.
3. FOR CANBUS NETWORK LENGTHS GREATER THAN 450FT(137M) CONTACT FACTORY.

**INTERLOCK WIRE NOTES (B):**

1. FIELD SUPPLIED WIRE
  - 2 CONDUCTOR 18AWG OR GREATER
  - RATED 600V
2. RUN FIELD SUPPLIED WIRES BETWEEN THE INDOOR UNIT AND THE CONDENSER.

**CRV300 INDOOR UNIT**

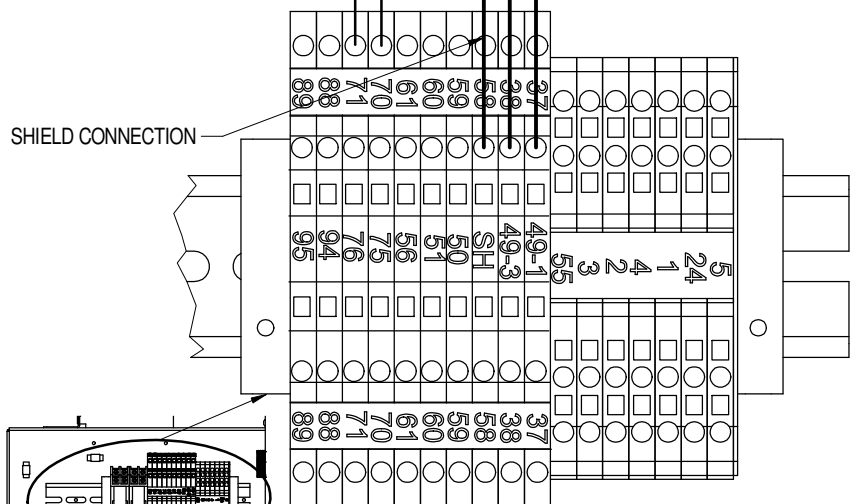

PARTIAL VIEW SHOWN FOR CLARITY

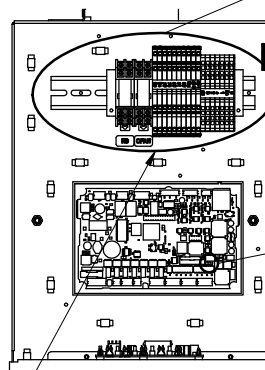

FACTORY WIRING BETWEEN ICOM AND TERMINAL STRIP.

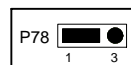

P78 TERMINATION JUMPER  
FACTORY SET TO PINS 2 AND 3,  
FIELD MUST REMOVE JUMPER  
AND REPLACE ON PINS 1 AND 2.



# LIEBERT® CRV

## SEISMIC DATA APPLICATION ASSUMPTIONS AND REQUIREMENTS 600mm (24in.) MODELS

The International Code Council's, International Building Code (IBC) has become the primary code document for the design and installation of building systems. Emerson Network Power has conducted analytical modeling and dynamic shake table testing of the Liebert® CRV600mm product to provide an option for those systems requiring seismic certification of compliance. This certification goes beyond the equipments ability to withstand the seismic forces: the IBC system approach includes the equipment, equipment anchorage, and the connections to the equipment [power, water supply and return and ducting]. In critical applications the equipment must be capable of performing its primary function after a seismic event within the limit of certification.

### Certification Criteria

The Liebert CRV600mm has two levels of certification for units installed rigid to floor without spring isolators. Both levels require unit mounting bracket as shown on page 8 and 9 detail A. The Liebert® CRV600 is approved for seismic applications when properly installed and used as intended and located in United States where the “design 5 percent damped spectral response acceleration at short periods adjusted for site class effects”,  $S_{DS}$  is as shown in the Table 1 and 2. Below grade, at grade or above grade installations are permitted and included in this approval. This certification is good for an  $I_p$  of 1.0 or 1.5.

The first level is  $S_{DS}=0.8$  which is the standard unit (Rigid mount only - no Floorstand).

Table 1. Shake table test parameters						
TestCriteria ICC-ESAC156	$S_{DS}(g)$	$z/h$	$A_{FLX}$	$A_{RIG}$	$A_{FLX\_VERT}$	$A_{RIG\_VERT}$
Rigid mount	0.8	1.0	1.28	0.96	0.54	0.22
Note:Equipment is qualified for $S_{DS}$ and $z/h$ values shown. Qualification may be valid for higher $S_{DS}$ where $z/h < 1.0$						

The second level for  $S_{DS}=2.00/2.50$  requires factory installed bracing (Rigid or Floorstand mount).

Table 2. Shake table test parameters						
Test Criteria ICC-ES AC 156	$S_{DS}^{\wedge}(g)$	$z/h^{\wedge}$	$A_{FLX}^{\wedge}$	$A_{RIG}^{\wedge}$	$A_{FLX\_VERT}^{\wedge}$	$A_{RIG\_VERT}^{\wedge}$
Rigid Base Mount or Floorstand	2.00	1.0	3.20	2.40	n/a	n/a
	2.50	0	n/a	n/a	1.68	0.68
Note: <sup>^</sup> Equipment is qualified for $S_{DS}$ and $z/h$ values shown. Qualification may be valid for varying $S_{DS}$ where $z/h < 1.0$						



# LIEBERT® CRV

---

## SEISMIC DATA APPLICATION ASSUMPTIONS AND REQUIREMENTS 600mm (24in.) MODELS

### Requirements for Anchorage

#### Anchors

1. Mounting requirement details such as brand, type, embedment depth, edge spacing, anchor spacing, concrete strength, wall bracing, and special inspection must be outlined and approved by the project Structural Engineer of Record.

#### Anchorage Surface

2. Structural floors, and housekeeping pads must also be seismically designed and approved by the project Structural Engineer of Record to withstand the seismic anchor loads as defined on the installation drawings. The installing contractor is responsible for the proper installation of all anchors and mounting hardware, observing the mounting requirement details outlined by the Engineer of Record. Contact the Manufacturer's Representative if a detailed Seismic Installation Calculation Package is required.

#### Connections to Unit

3. Electrical wiring, conduit, and/or other connections to the equipment is the responsibility of others. Data and recommendations are supplied here and in the unit installation supplement for seismic installation.



## SEISMIC DATA

### ANCHORAGE RIGID FLOORSTAND DIMENSIONAL DATA

#### 600mm (24in.) MODELS

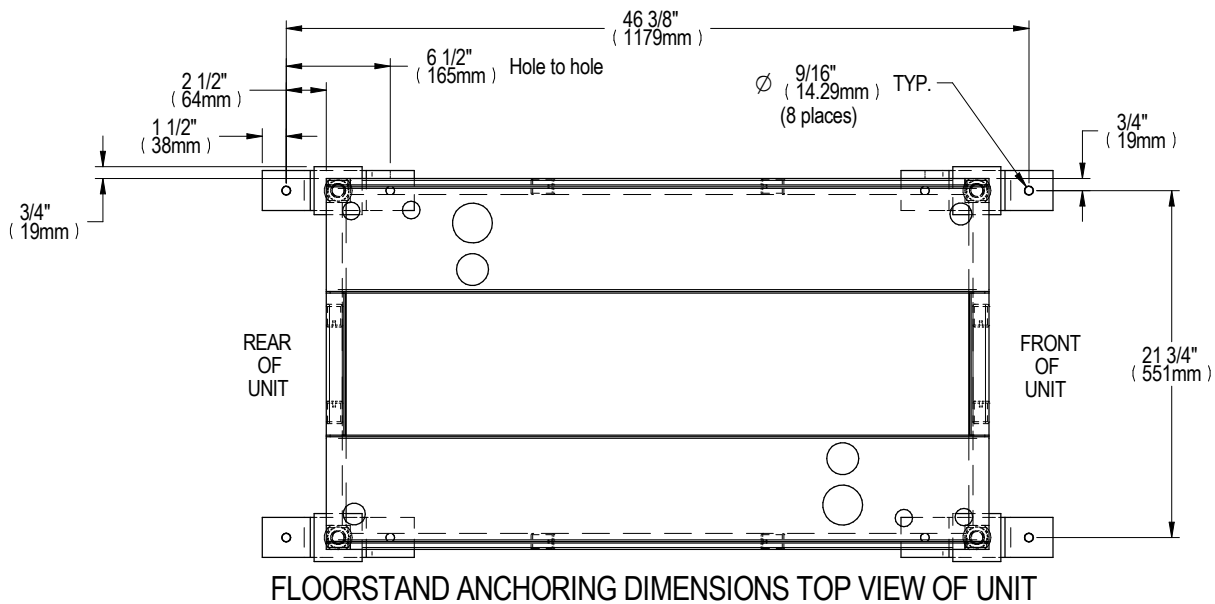
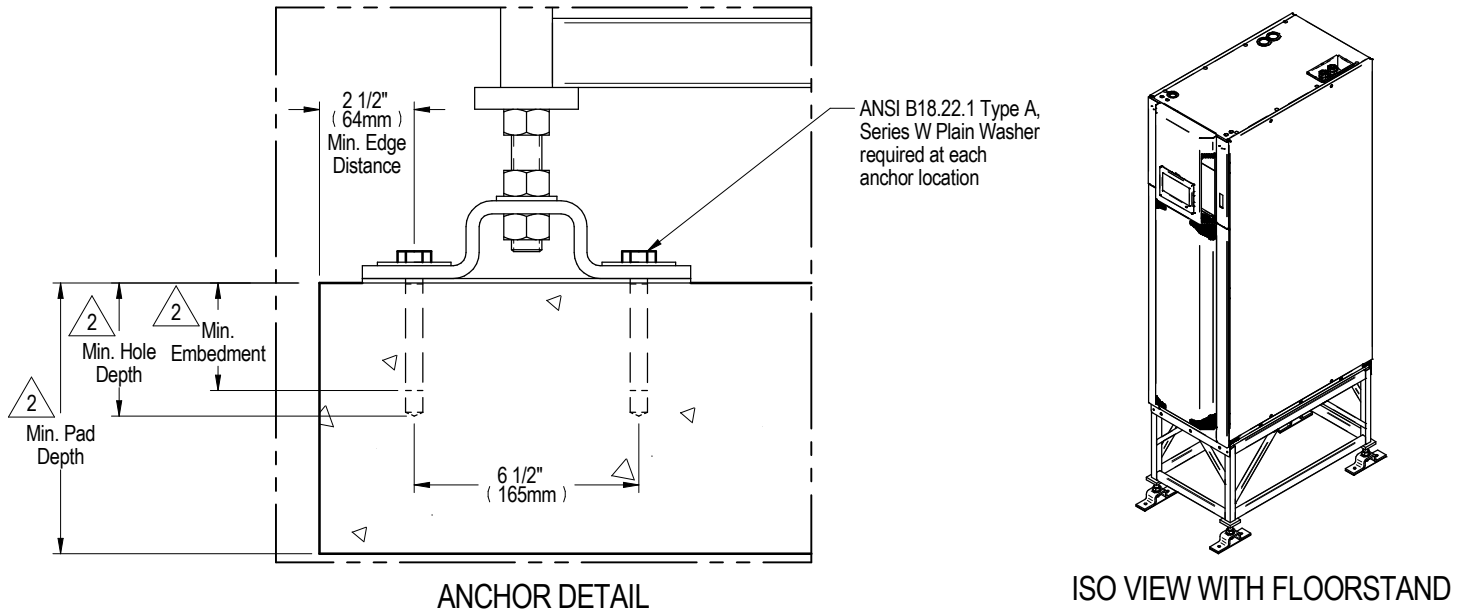

Model #	Sds	Anchor Size	Operating Mass lb (kg) <sup>3</sup>	Maximum Compressive lb (kg)	Maximum Load per Anchor lb (kg)	
					Tension	Shear
CR020 & CR035 (Air & Water) and CR040 (Chilled Water)	2.5	1/2"	1052 (478)	1256 (570)	1032 (468)	187 (85)

**Notes:**

1. Anchor bolt sized per Hilti Kwik Bolt TZ carbon and stainless in concrete ICC ESR-1917. Alternates are subject to review by Vertiv or Engineer of Record.

2. Specified by Engineer of Record.

3. Operating Mass includes the operating refrigerant and water volume.

4. All loads are calculated per ASCE 7-05, Chapter 13.6  $R_p=6.0$ ,  $a=2.5$ ,  $I_p=1.5$

**SEISMIC DATA**  
**ANCHORAGE FLOOR DIMENSIONAL DATA 600mm (24in.) MODELS**

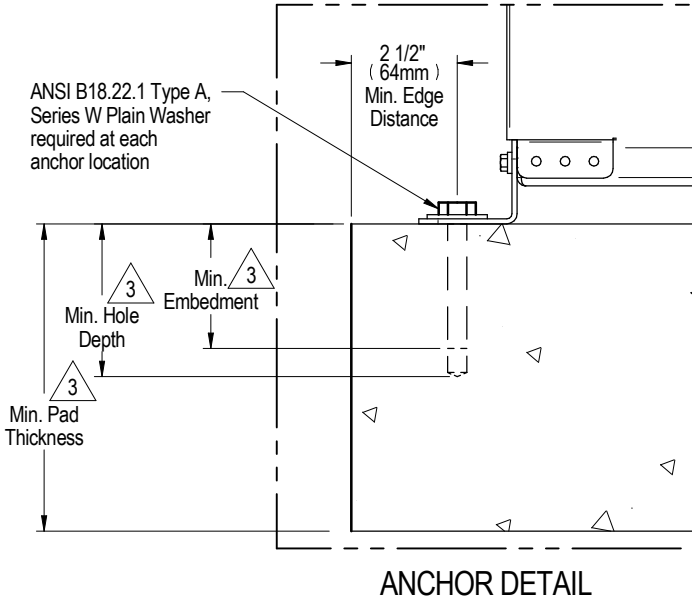

Anchor bolt sized per HILTI KWIK BOLT TZ carbon and stainless In concrete ICC ESR-1917. Alternates are subject to review by Vertiv or Engineer of Record.

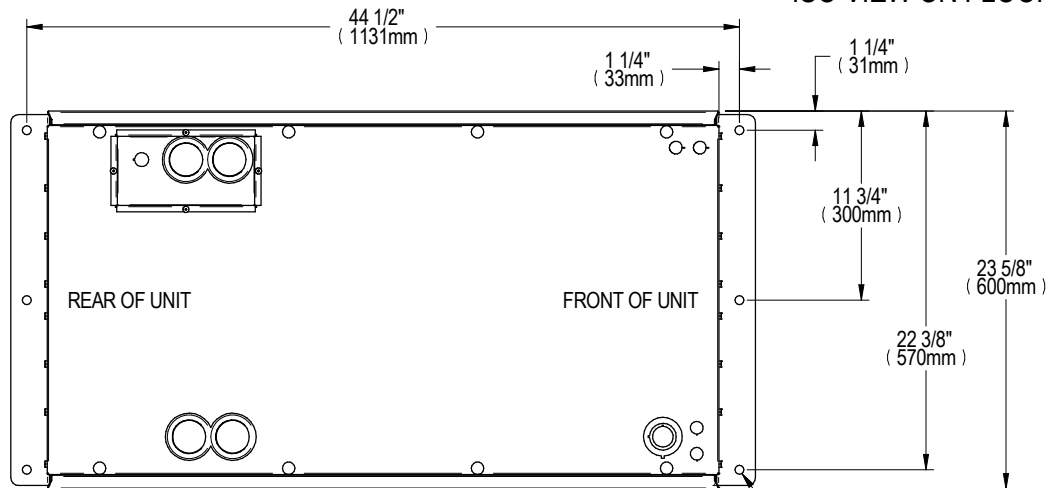
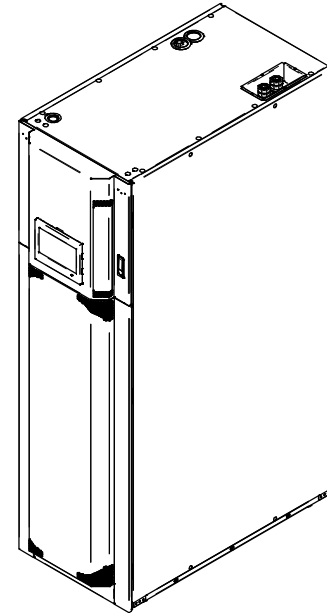

View from top of the CRV unit.  
 Front and rear doors removed for clarity.

Model #	Sds	Anchor Size	Operating Mass lb. (kg)	Maximum Compressive lb. (kg)	Maximum Load per Anchor lb. (kg)	
					Tension	Shear
CR020 & CR035 (Air & Water) and CR040 (Chilled Water	0.8	1/2"	938 (426)	505 (229)	249 (113)	70 (32)
CR020 & CR035 (Air & Water) and CR040 (Chilled Water	2.5	1/2"	952 (432)	1249 (567)	981 (446)	221 (100)

Notes:

1. All loads are calculated per ASCE 7-05, Chapter 13.6  $R_p=6.0$ ,  $a=2.5$ ,  $l_p=1.5$

2. Operating mass includes the operating refrigerant and water volume.

3. Specified by Engineer of Record.

**SEISMIC DATA**  
**FLOORSTAND OVERALL DIMENSIONAL DETAIL 600mm (24in.) MODELS**

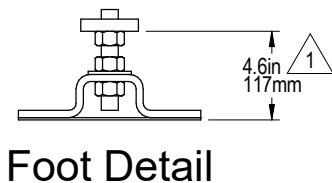
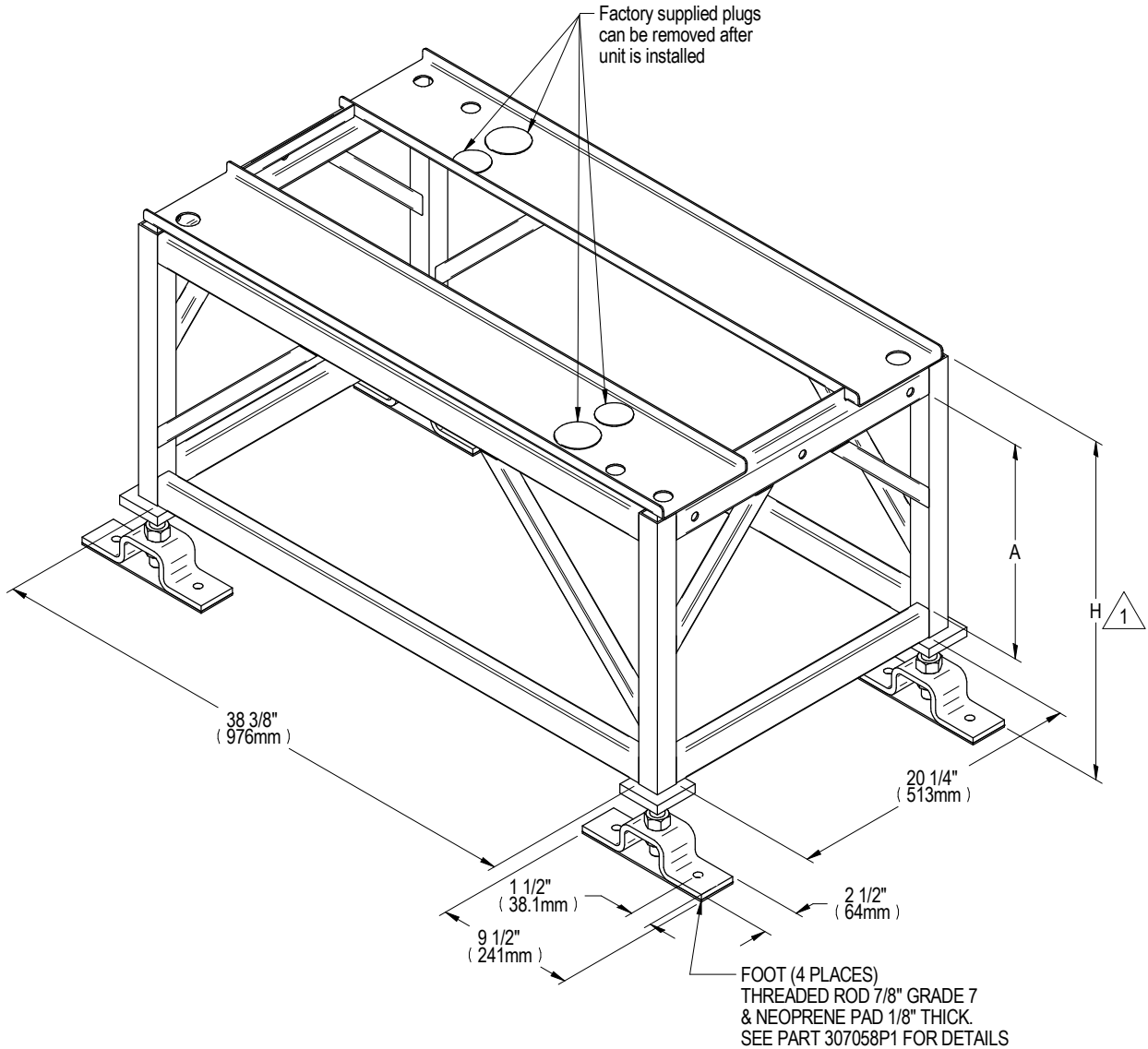

Height in. (mm)	
H <sup>1</sup>	A
12 (305)	8 3/4 (222)
18 (457)	14-3/4 (375)
24 (610)	20-3/4 (527)

Notes:

- <sup>1</sup>. Foot provides ±0.25in (6.4mm) adjustment from nominal height H

## SEISMIC DATA ELECTRICAL WIRING CONSIDERATIONS 600mm (24in.) MODELS

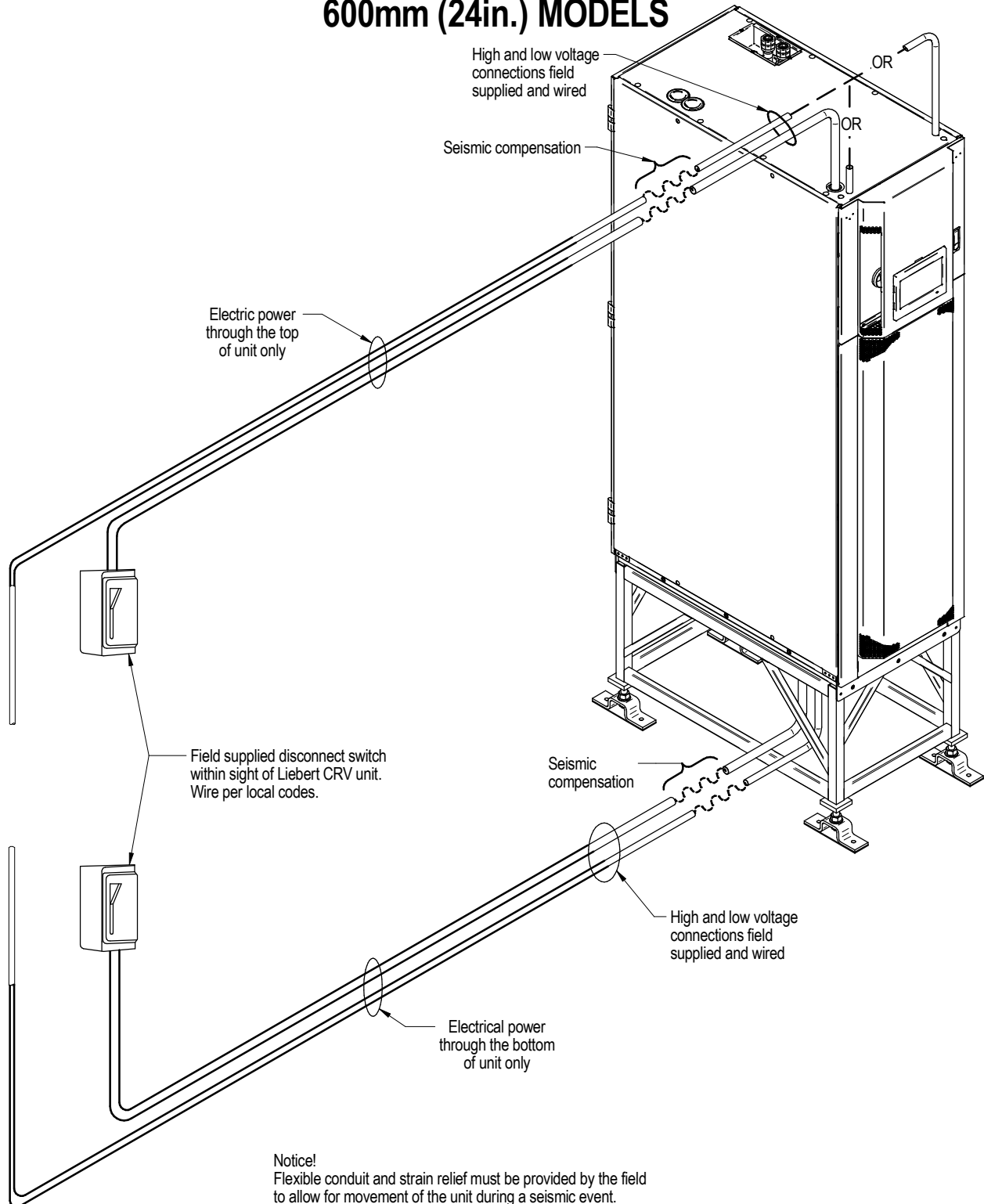

**Notice!**  
Flexible conduit and strain relief must be provided by the field to allow for movement of the unit during a seismic event. The flexible conduit shall have at least one bend between the rigid conduit connection at the unit cabinet and the connection to the rigid conduit or foundation.

## SEISMIC DATA

### PIPING CONSIDERATIONS 600mm (24in.) MODELS

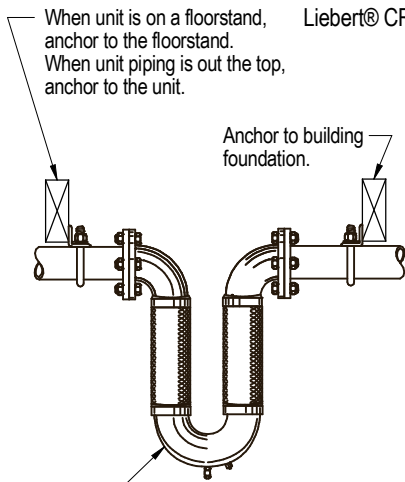
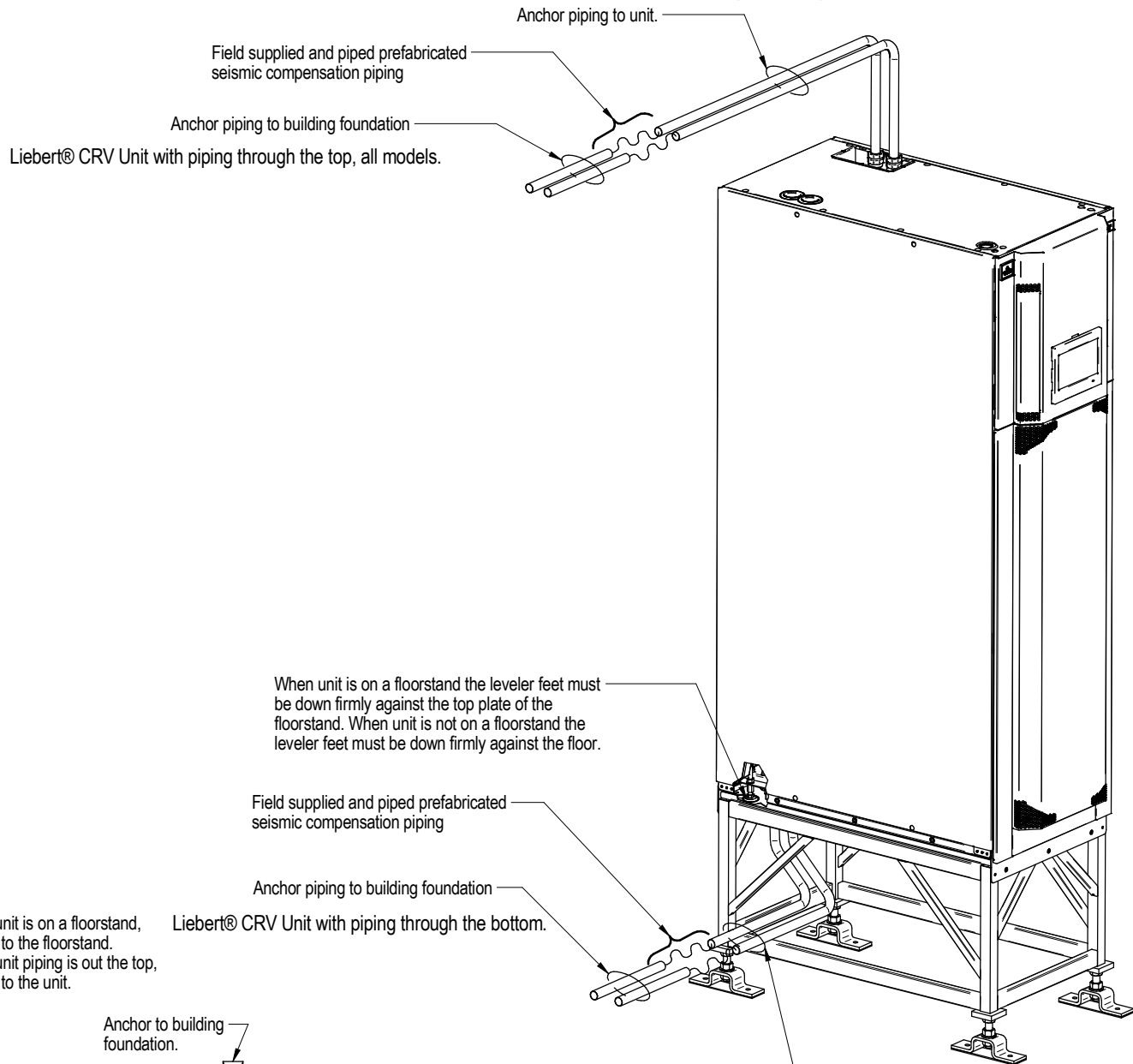

**FLEXIBLE LOOP EXAMPLE**

**Flexible Loops:**  
All units shall be attached to the piping system using flexible loops designed for seismic movement. Flexible loops shall be capable of movement in the  $\pm X$ ,  $\pm Y$  and  $\pm Z$  planes and must completely isolate the equipment from the piping. The loops shall be suitable for an operating pressure and temperature of the system, refer to Liebert® installation instructions. This includes condensate drainage, refrigerant lines, and chilled water supply and return lines. Follow manufacturer's installation instructions for proper seismic application of flexible loops.

**SEISMIC DATA  
CERTIFICATION TESTED CONNECTION DETAIL  
600mm (24in.) MODELS**

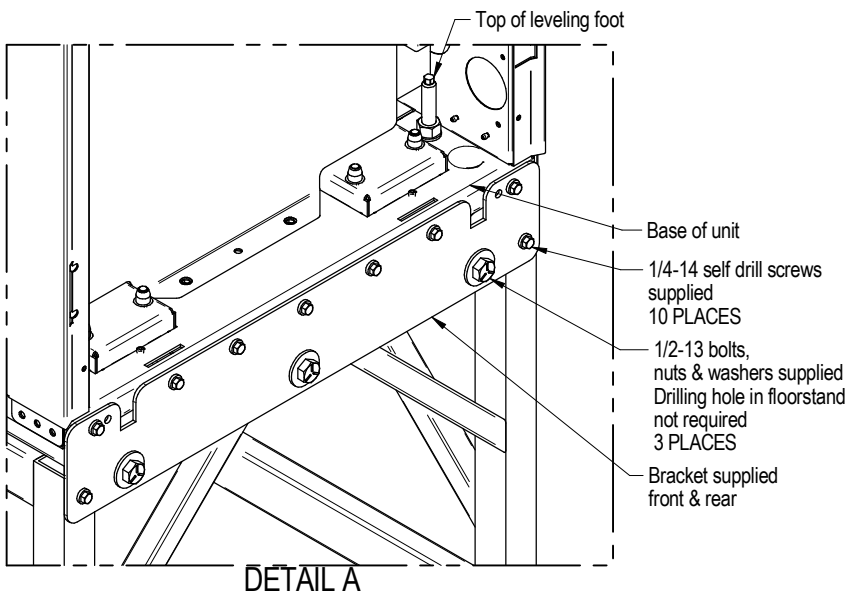
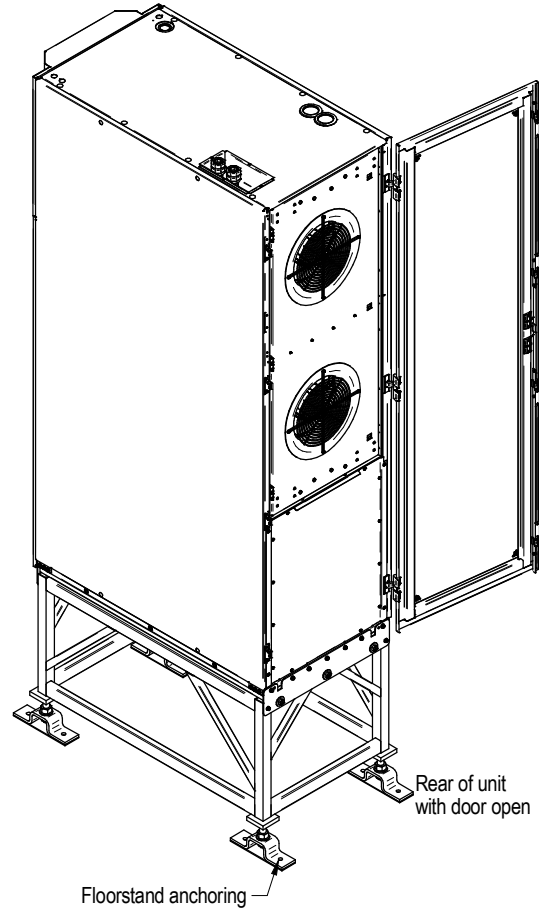
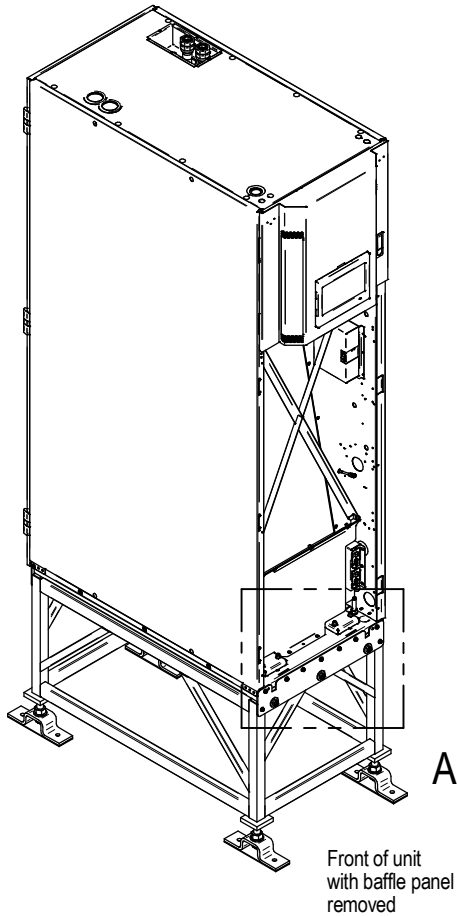

**Notes:**

- 1.) To level the unit lower the four stabilizing feet until they make contact with the floorstand. (SEE DETAIL "A")
- 2.) Anchor the bracket to the unit and the floorstand using the screws that are provided, all factory supplied screws must be used to maintain seismic certification (SEE DETAIL "A").
- 3.) The same mounting bracket is used in the front and rear of the unit.
- 4.) This document is not to be used for field installation, see Liebert® CRV manual.

## SEISMIC DATA CERTIFICATION TESTED CONNECTION DETAIL 600mm (24in.) MODELS

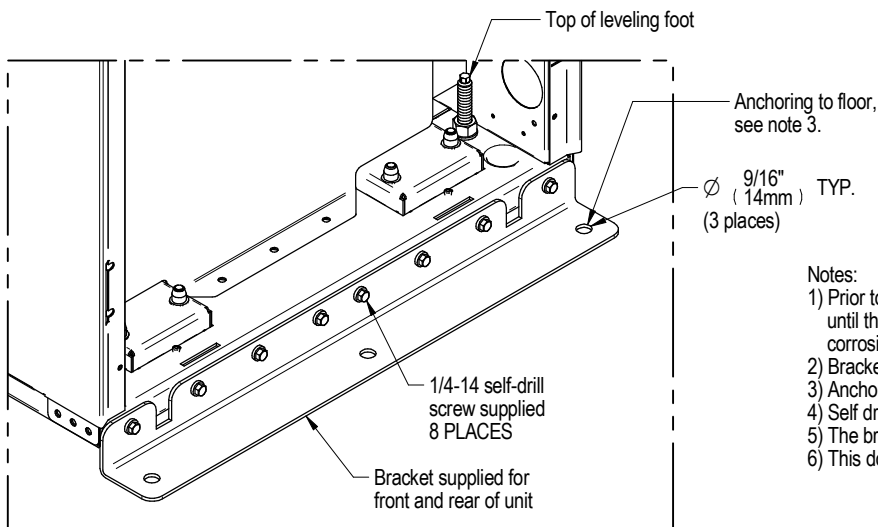
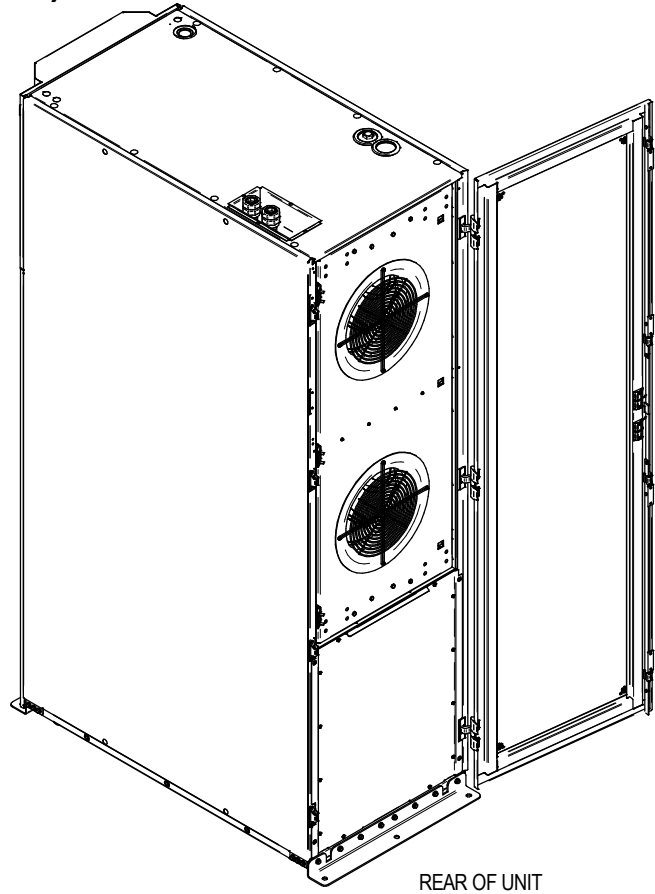
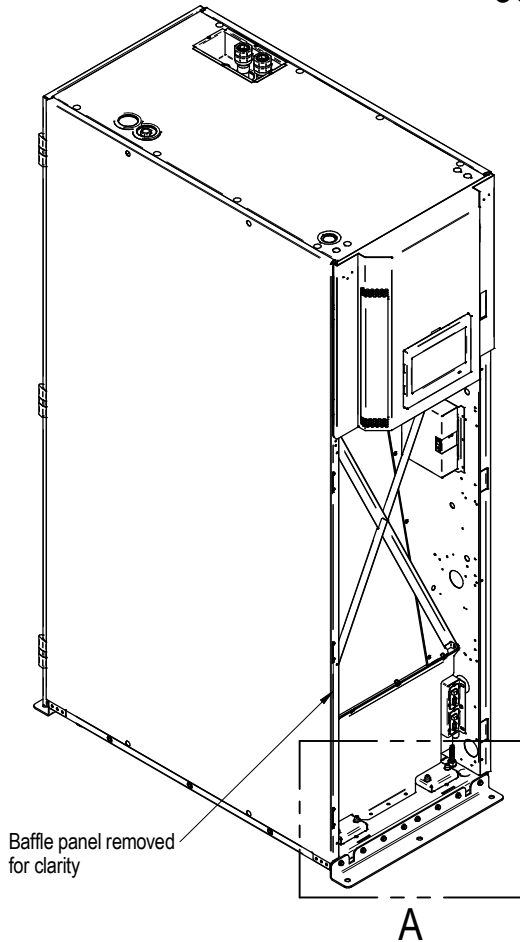

**DETAIL A**  
FRONT OF UNIT

**Notes:**

- 1) Prior to mounting bracket, lower the four leveling feet (see detail "B") until they make contact with the floor. Ensure that unit is level to avoid corrosion or health hazards caused by condensate accumulation.
- 2) Bracket to be centered on base of Liebert® CRV unit (shown in detail "A").
- 3) Anchor bracket to floor. Refer to anchoring detail on page 4.
- 4) Self drill screws (see detail "A") to secure bracket to Liebert® CRV unit.
- 5) The bracket is also used in the rear of the Liebert® CRV unit.
- 6) This document is not to be used for field installation.



# LIEBERT® CRV

## SEISMIC DATA APPLICATION ASSUMPTIONS AND REQUIREMENTS 300mm (12in.) MODELS

The International Code Council's, International Building Code (IBC) has become the primary code document for the design and installation of building systems. Vertiv has conducted analytical modeling and dynamic shake table testing of the Liebert® CRV300mm product to provide an option for those systems requiring seismic certification of compliance. This certification goes beyond the equipments ability to withstand the seismic forces: the IBC system approach includes the equipment, equipment anchorage, and the connections to the equipment [power, water supply and return and ducting]. In critical applications the equipment must be capable of performing its primary function after a seismic event within the limit of certification.

### Certification Criteria

The Liebert® CRV300mm has two levels of certification for units installed rigid to floor without spring isolators. Both levels require unit mounting bracket as shown on page 8 and 9 detail A. The Liebert® CRV300 is approved for seismic applications when properly installed and used as intended and located in United States where the “design 5 percent damped spectral response acceleration at short periods adjusted for site class effects”,  $S_{DS}$  is as shown in the Table 1 and 2. Below grade, at grade or above grade installations are permitted and included in this approval. This certification is good for an  $I_p$  of 1.0 or 1.5.

The first level is  $S_{DS}=0.8$  which is the standard unit (Rigid mount only - no Floorstand).

Table 1. Shake table test parameters						
TestCriteria ICC-ESAC156	$S_{DS}(g)$	z/h	$A_{FLX}$	$A_{RIG}$	$A_{FLX\_VERT}$	$A_{RIG\_VERT}$
Rigid mount	0.8	1.0	1.28	0.96	0.54	0.22
Note: Equipment is qualified for $S_{DS}$ and z/h values shown. Qualification may be valid for higher $S_{DS}$ where z/h < 1.0						

The second level for  $S_{DS}=2.00/2.50$  requires factory installed bracing (Rigid or Floorstand mount).

Table 2. Shake table test parameters						
Test Criteria ICC-ES AC 156	$S_{DS}$ (g)	z/h	$A_{FLX}$	$A_{RIG}$	$A_{FLX\_VERT}$	$A_{RIG\_VERT}$
Rigid Base Mount or Floorstand	2.00	1.0	3.20	2.40	n/a	n/a
	2.50	0	n/a	n/a	1.68	0.68
Note: Equipment is qualified for $S_{DS}$ and z/h values shown. Qualification may be valid for varying $S_{DS}$ where z/h < 1.0						





# LIEBERT® CRV

---

## SEISMIC DATA APPLICATION ASSUMPTIONS AND REQUIREMENTS 300mm (12 in.) MODELS

### Requirements for Anchorage

#### Anchors

1. Mounting requirement details such as brand, type, embedment depth, edge spacing, anchor spacing, concrete strength, wall bracing, and special inspection must be outlined and approved by the project Structural Engineer of Record.

#### Anchorage Surface

2. Structural floors, and housekeeping pads must also be seismically designed and approved by the project Structural Engineer of Record to withstand the seismic anchor loads as defined on the installation drawings. The installing contractor is responsible for the proper installation of all anchors and mounting hardware, observing the mounting requirement details outlined by the Engineer of Record. Contact the Manufacturer's Representative if a detailed Seismic Installation Calculation Package is required.

#### Connections to Unit

3. Electrical wiring, conduit, and/or other connections to the equipment is the responsibility of others. Data and recommendations are supplied here and in the unit installation supplement for seismic installation.

## SEISMIC DATA ANCHORAGE RIGID FLOORSTAND DIMENSIONAL DATA 300mm (12 in.) MODELS

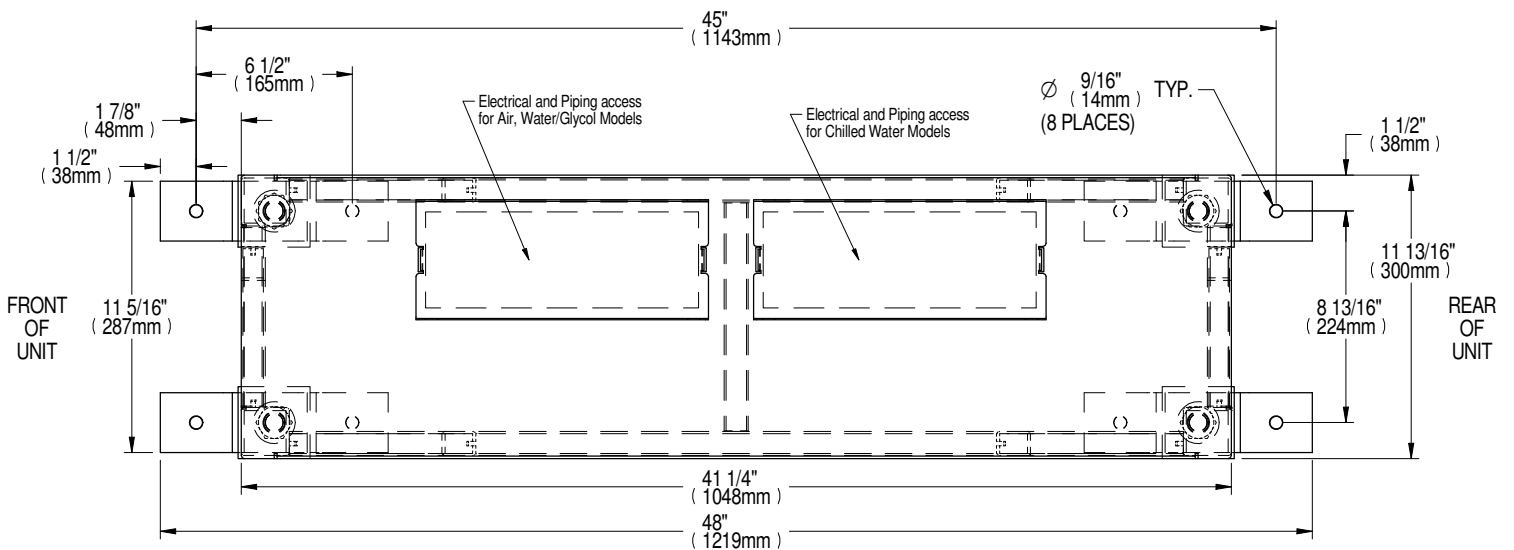
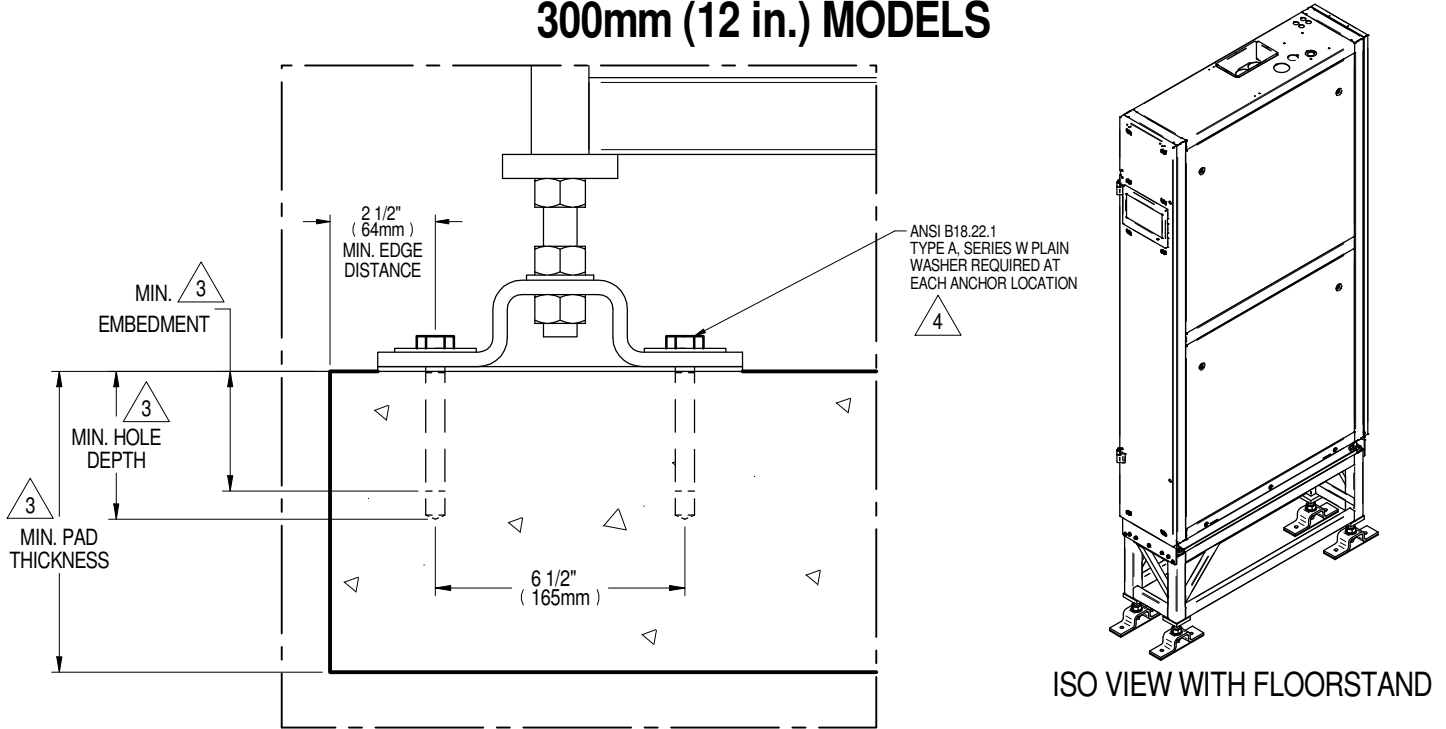

FLOORSTAND AND ANCHORING DIMENSIONS TOP VIEW OF UNIT

Model #	Sds	Anchor Size	Operating mass lb (kg) 2	Maximum Compressive lb (kg)	Maximum Load per Anchor lb (kg)	
					Tension	Shear
CR019 (Air & Water) and CR032 (Chilled Water)	2.5	1/2"	636 (289)	1493 (678)	1359 (617)	113 (51)

Notes:

1. All loads are calculated per ASCE 7-05, Chapter 13.6 Rp=6.0, a=2.5, lp=1.5.

2. Operating mass includes the operating refrigerant and water volume.

3. Specified by Engineer of record.

4. Anchor Bolt sized per Hilti Kwik Bolt TZ Carbon and stainless in concrete, ICC ESR-19.17. Alternates are subject to review by Vertiv™ or Engineer Of Record.

## SEISMIC DATA

### ANCHORAGE FLOOR DIMENSIONAL DATA 300mm (12 in.) MODELS

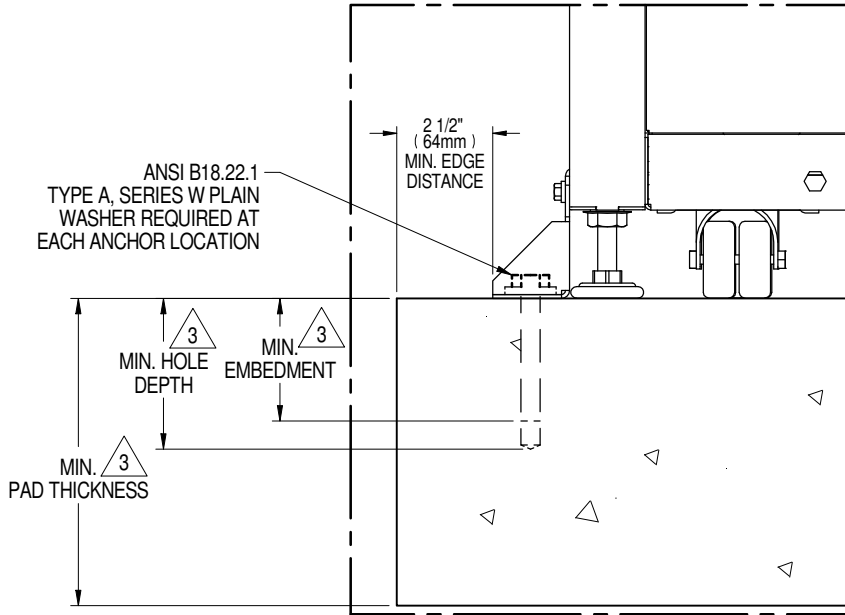

ANCHORAGE DETAIL 4

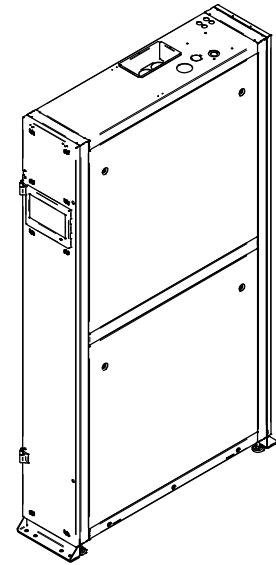

ISO VIEW ON FLOOR

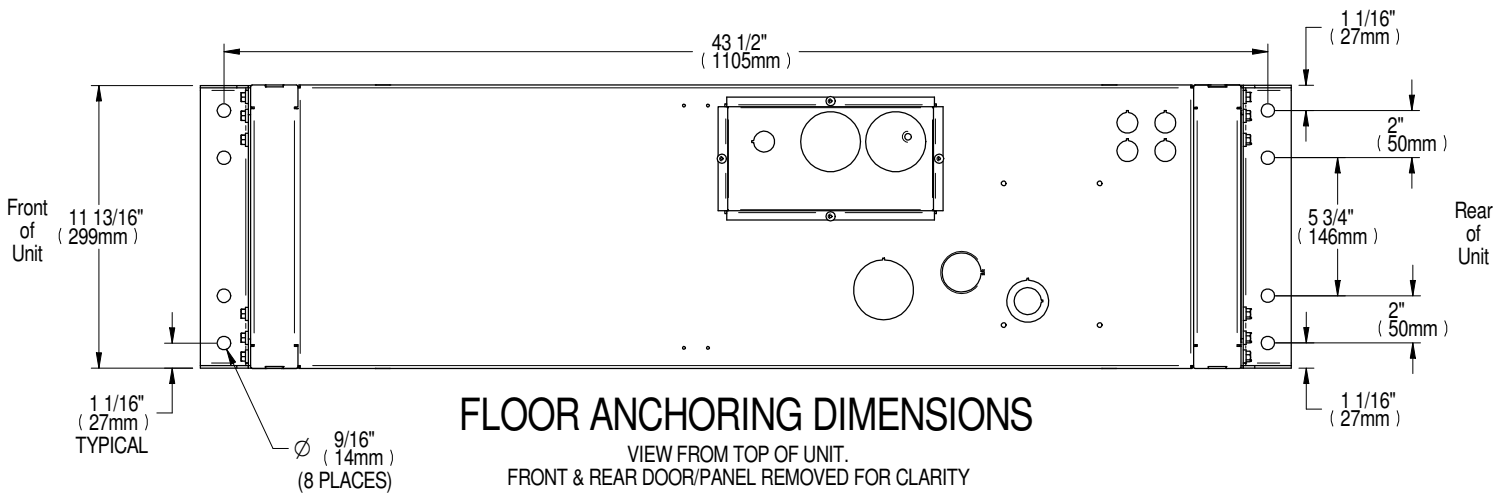

### FLOOR ANCHORING DIMENSIONS

VIEW FROM TOP OF UNIT.  
FRONT & REAR DOOR/PANEL REMOVED FOR CLARITY

Model #	Sds	Anchor Size	Operating mass lb (kg) <span style="border: 1px solid black; padding: 2px;">2</span>	Maximum Compressive lb (kg)	Maximum Load per Anchor lb (kg)	
					Tension	Shear
CR019 (Air & Water) and CR032 (Chilled Water)	0.8	1/2"	545 (247)	453 (206)	345 (157)	29 (13)
CR019 (Air & Water) and CR032 (Chilled Water)	2.5	1/2"	548 (249)	1281 (582)	1173 (533)	92 (42)

Notes:

1. All loads are calculated per ASCE 7-05, Chapter 13.6  $R_p=6.0$ ,  $a=2.5$ ,  $I_p=1.5$ .

2. Operating mass includes the operating refrigerant and water volume.

3. Specified by Engineer of record.

4. Anchor Bolt sized per Hilti Kwik Bolt TZ Carbon and stainless in concrete, ICC ESR-19.17. Alternates are subject to review by Vertiv™ or Engineer Of Record.

## SEISMIC DATA

### FLOORSTAND OVERALL DIMENSIONAL DETAIL 300mm (12 in.) MODELS

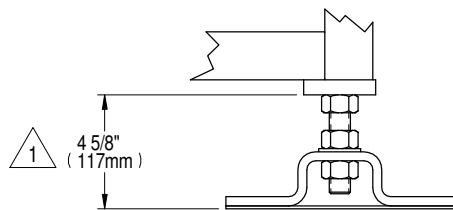
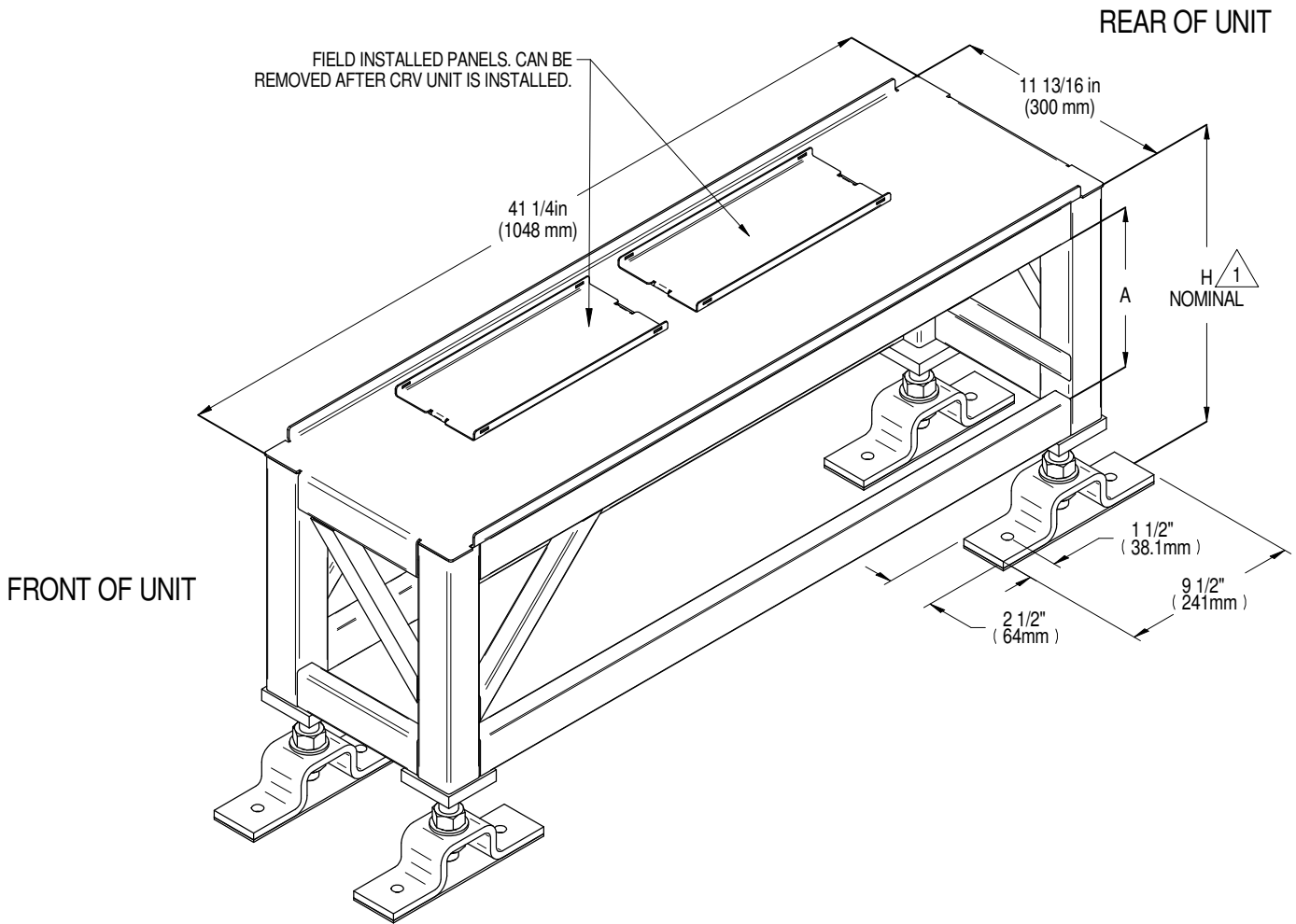

**FOOT DETAIL**

NOMINAL $\triangle$ 1	Height in (mm)	
	H $\triangle$ 1	A
12	12 (305)	8-3/4 (222)
18	18 (457)	14-3/4 (375)
24	24 (610)	20-3/4 (527)

Notes:

$\triangle$  1. Foot provides  $\pm 0.25$  in (6.4mm) adjustment from nominal height H.

**SEISMIC DATA**  
**SEISMIC WIRING CONSIDERATIONS 300mm (12 in.) MODELS**

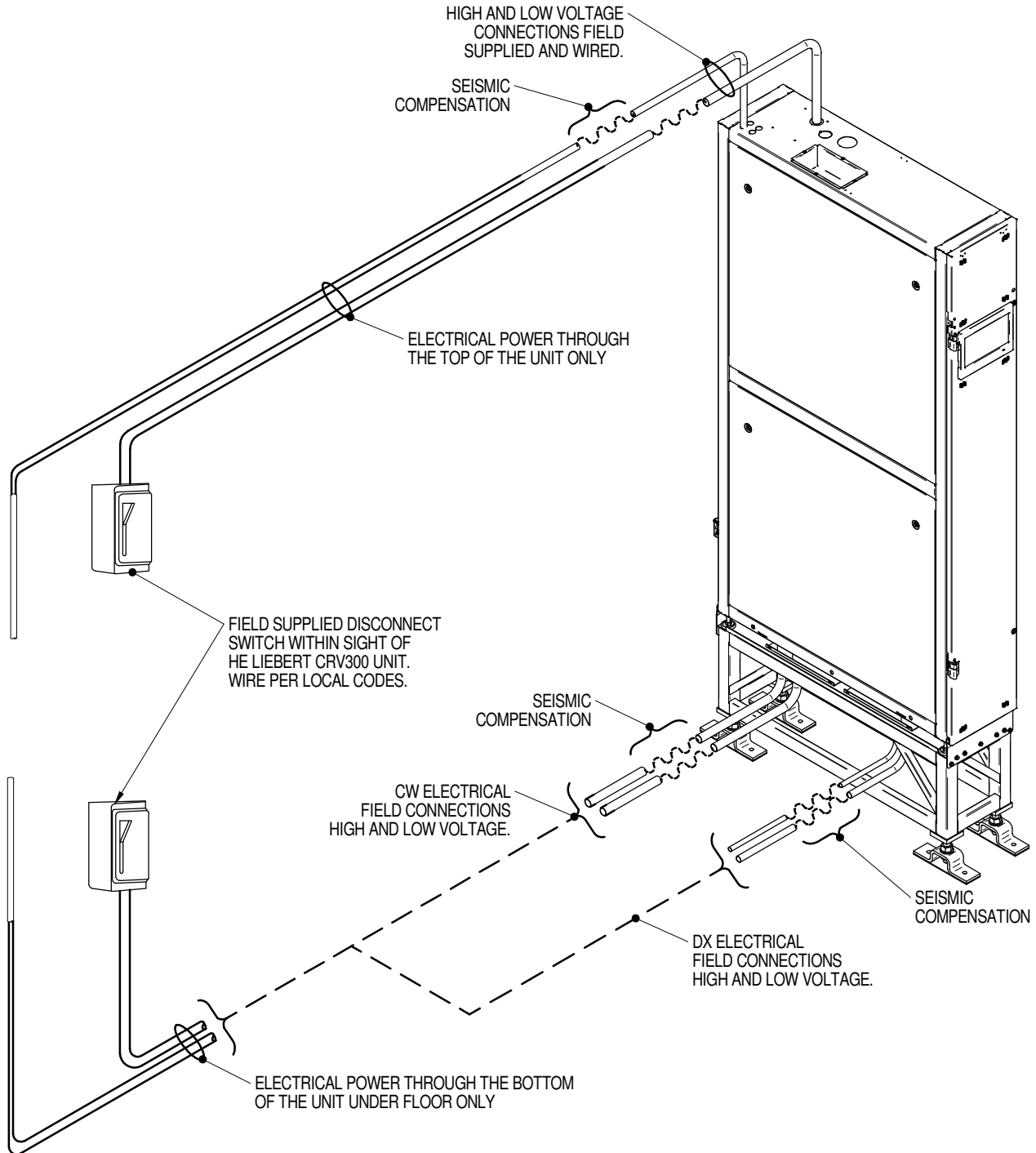

**NOTES:**

1. FLEXIBLE CONDUIT AND STRAIN RELIEF MUST BE PROVIDED BY THE FIELD TO ALLOW FOR MOVEMENT OF THE UNIT DURING A SEISMIC EVENT. THE FLEXIBLE CONDUIT SHALL HAVE AT LEAST ONE BEND BETWEEN THE RIGID CONDUIT CONNECTION AT THE UNIT CABINET AND THE CONNECTION TO THE RIGID CONDUIT OR FOUNDATION.

## SEISMIC DATA

### PIPING CONSIDERATIONS 300mm (12 in.) MODELS

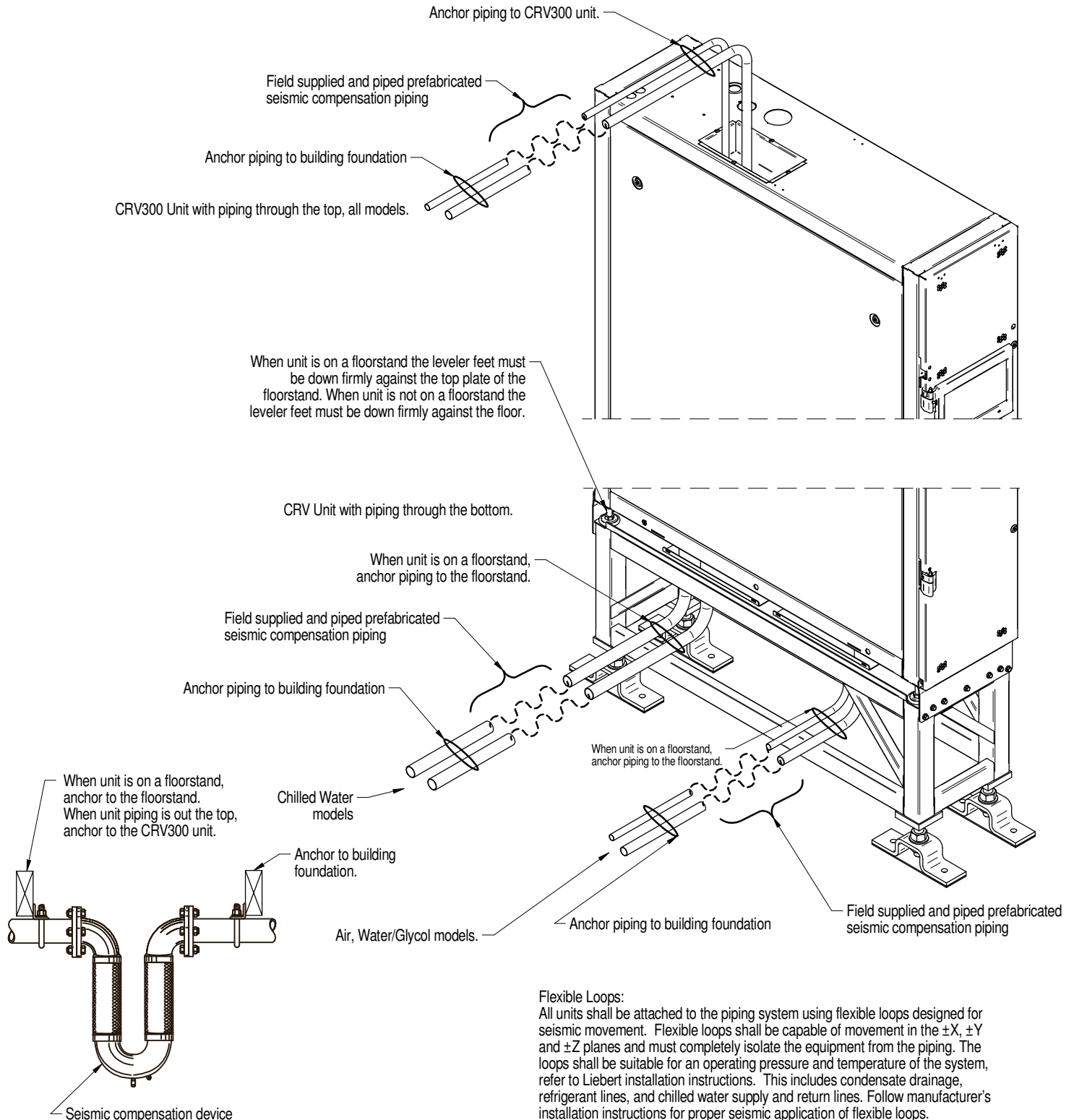

## SEISMIC DATA

### CERTIFICATION TESTED CONNECTION DETAIL 300mm (12 in.) MODELS

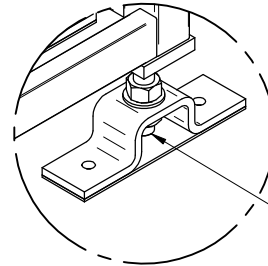
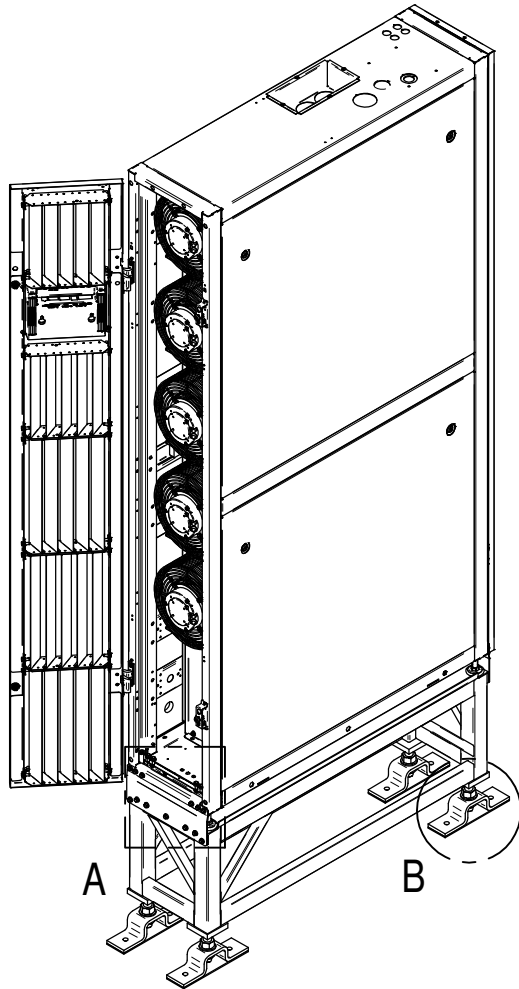

7/8" Grade 7 threaded rod with  
1/8" thick neoprene pad  
(typical 4 places)

#### DETAIL B

Install both inner and outer seismically rated hold down brackets with the factory provided self drilling screws. All screws must be used to retain seismic rating.

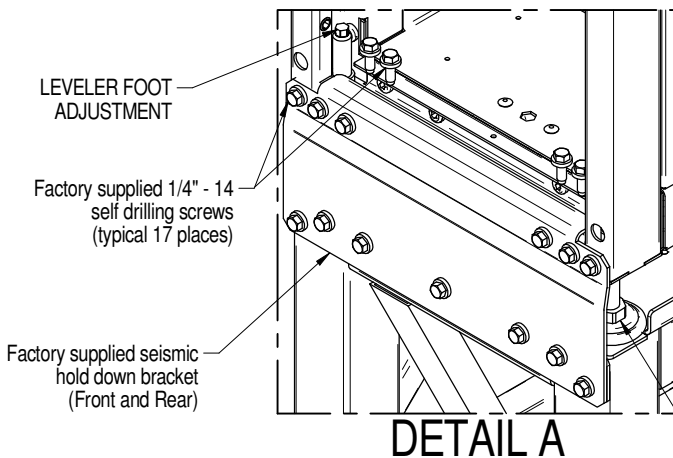
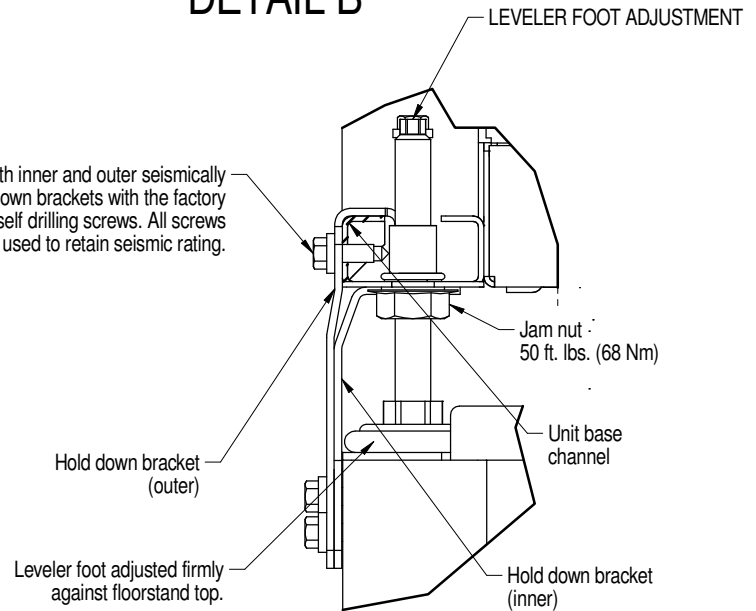

#### DETAIL A

LEVELER FOOT

#### Notes:

1. Prior to mounting brackets, lower the four leveling feet (see Detail "A") until they make contact with the floorstand. Ensure that unit is level to avoid corrosion or health hazards caused by condensate accumulation.
2. Anchor both the inner and outer brackets to the unit and the floorstand using the screws that are provided; all factory supplied screws must be used to maintain seismic certification.
3. The brackets are to be secured to the floorstand using factory supplied screws; all the holes in the bracket MUST be used to maintain seismic certification.
4. The same two inner and outer mounting brackets are used in the front and rear of the unit.
5. This document is not to be used for field installation, see Liebert® CRV User manual.

**SEISMIC DATA**  
**CERTIFICATION TESTED CONNECTION DETAIL 300mm (12 in.) MODELS**

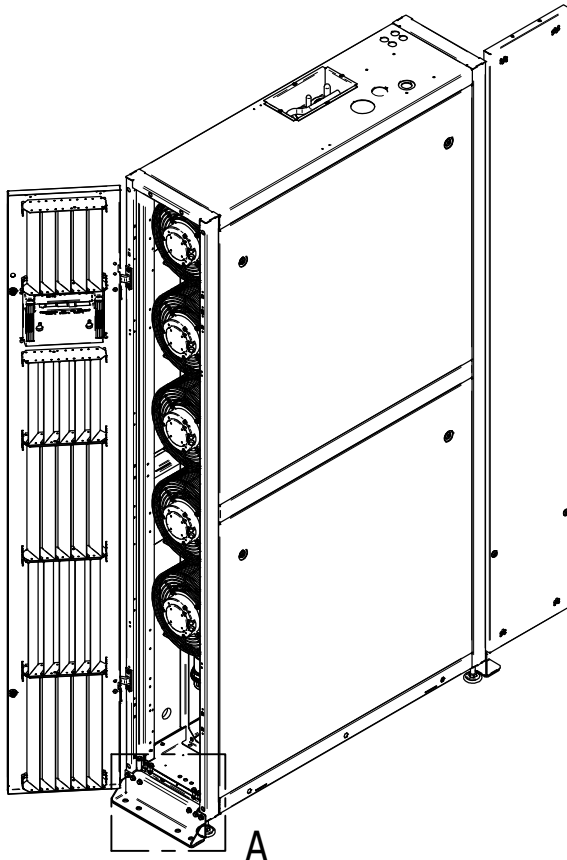

**A**  
**Front of Unit  
 with door open**

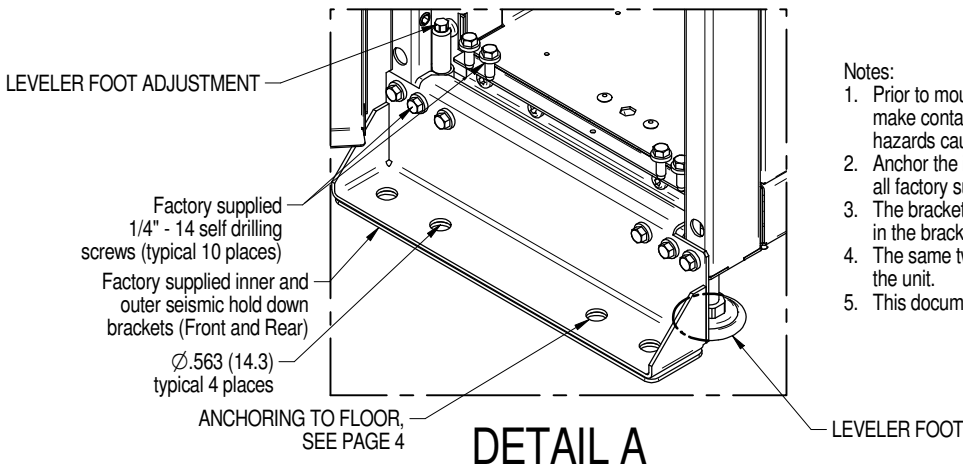
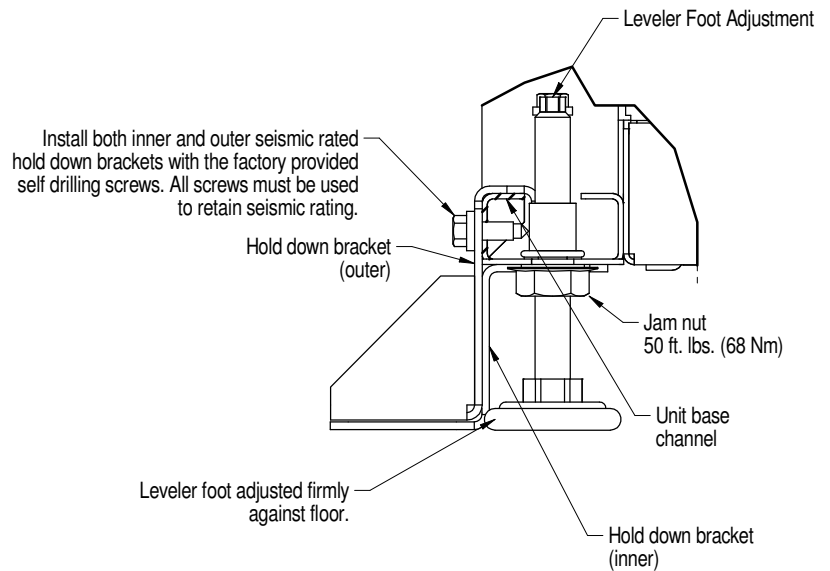

**Notes:**

1. Prior to mounting brackets, lower the four leveling feet (see Detail "A") until they make contact with the floor. Ensure that unit is level to avoid corrosion or health hazards caused by condensate accumulation.
2. Anchor the inner and outer brackets to the unit using the screws that are provided all factory supplied screws must be used to maintain seismic certification.
3. The brackets are to be secured to the floor using field supplied anchors; all the holes in the bracket **MUST** be used to maintain seismic certification.
4. The same two inner and outer mounting brackets are used in the front and rear of the unit.
5. This document is not to be used for field installation, see Liebert® CRV User manual.



## DIMENSIONAL DATA

### 600mm (24in.) RIGID FLOOR MOUNT BRACKET

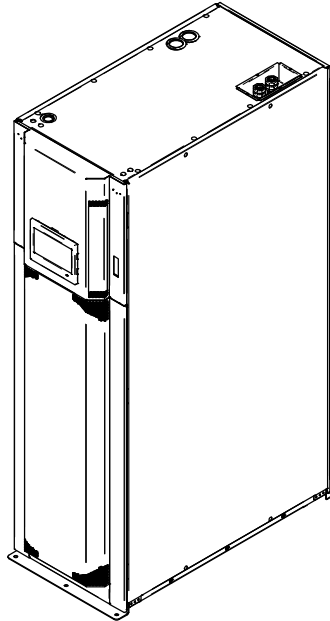

ISO VIEW ON FLOOR

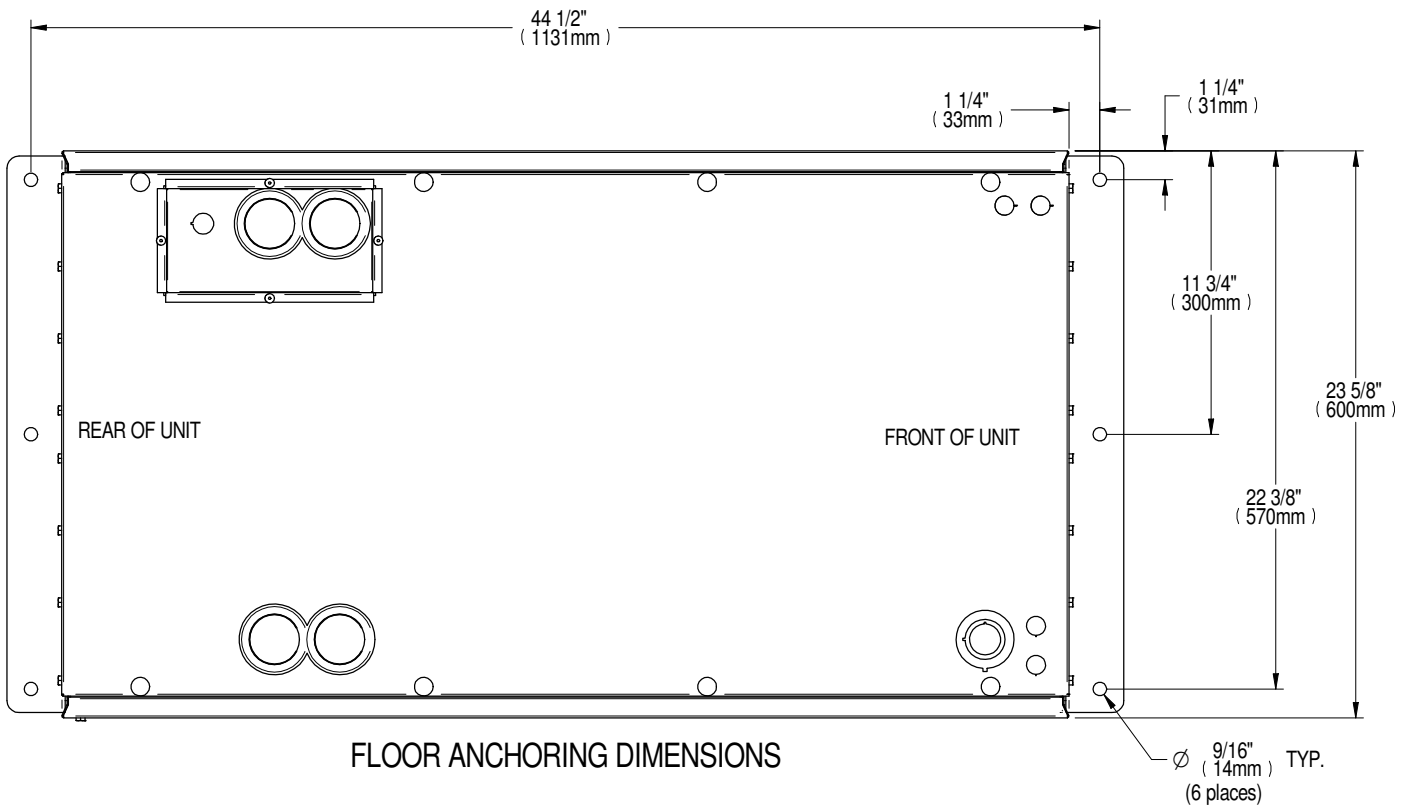

View from top of the Liebert® CRV unit.  
Front and rear doors removed for clarity.

**ANCHORING DETAIL**  
**600mm (24in.) RIGID FLOOR MOUNT BRACKET**

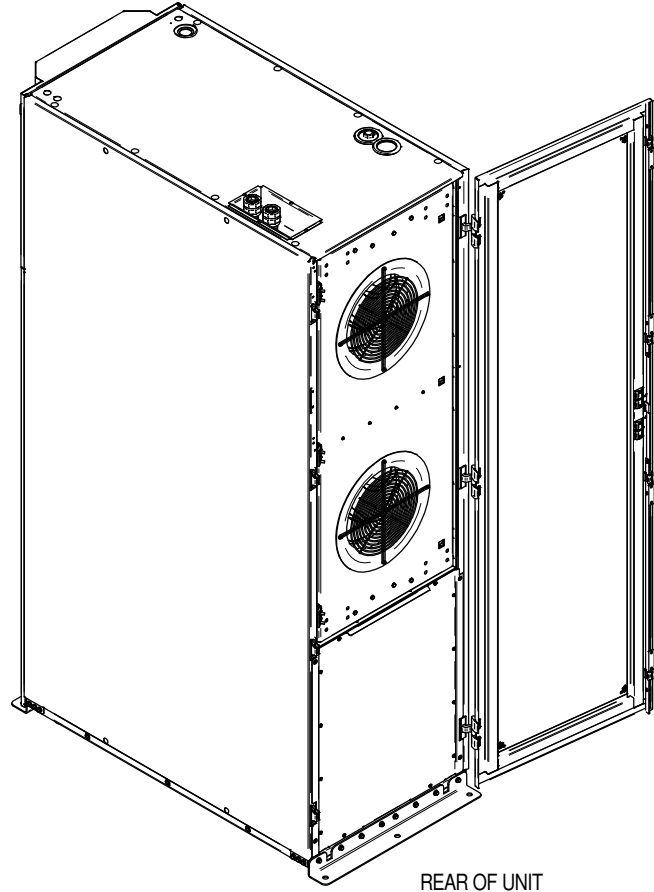
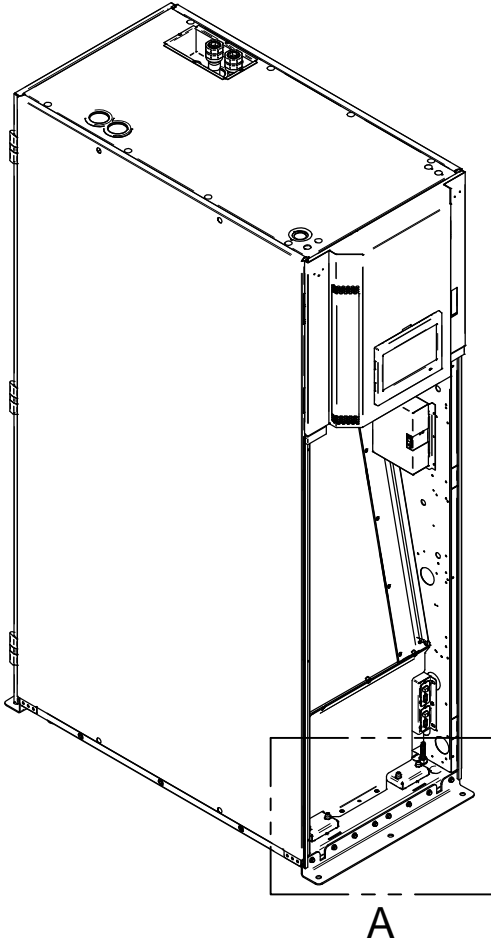

REAR OF UNIT

A

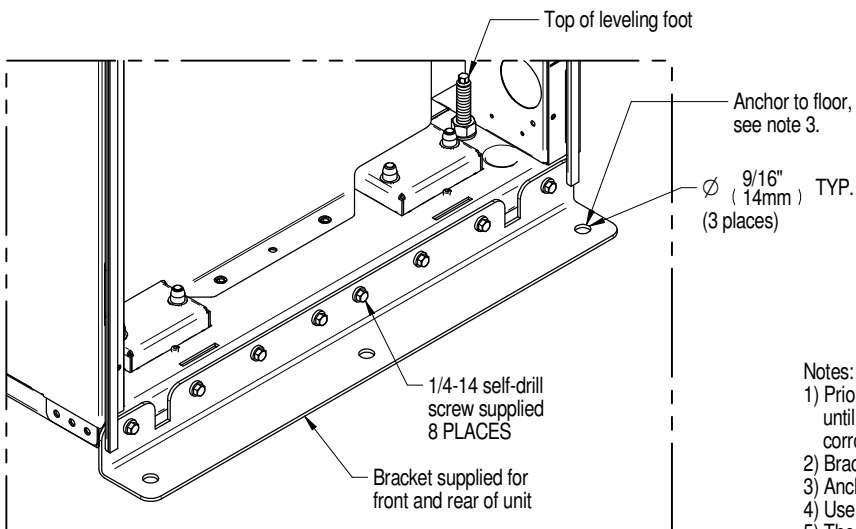

DETAIL A

FRONT OF UNIT

Notes:

- 1) Prior to mounting bracket, lower the four leveling feet (see detail "A") until they make contact with the floor. Ensure that unit is level to avoid corrosion or health hazards caused by condensate accumulation.
- 2) Bracket to be centered on base of Liebert® CRV unit (shown in detail "A").
- 3) Anchor bracket to floor. Refer to anchoring detail, page 1.
- 4) Use self drilling screws to secure bracket to Liebert® CRV unit (see detail A).
- 5) The same bracket is used in the front and rear of the Liebert® CRV unit.
- 6) This document is not to be used for field installation.

## DIMENSIONAL DATA FLOORSTAND 600mm (24in.) MODELS

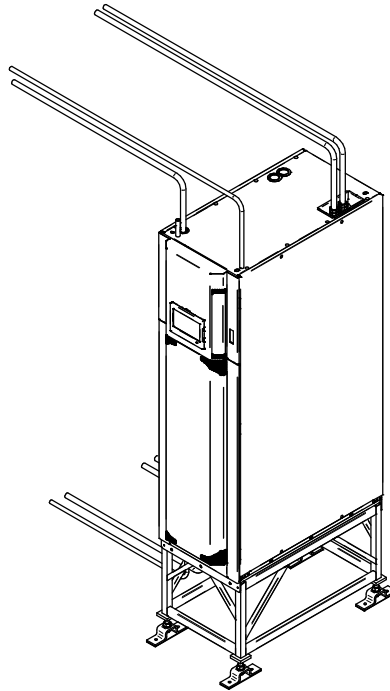

ISO VIEW WITH FLOORSTAND

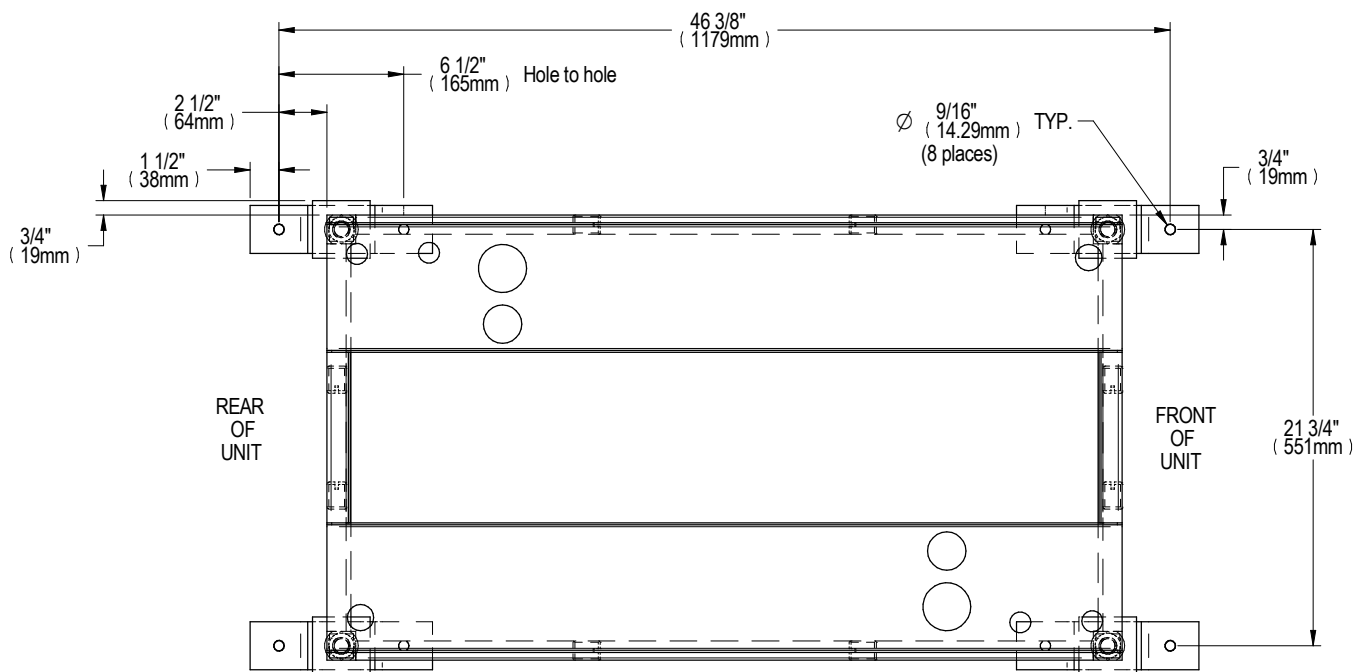

FLOORSTAND ANCHORING DIMENSIONS TOP VIEW OF UNIT

**DIMENSIONAL DATA**  
**FLOORSTAND 600mm (24in.) MODELS**

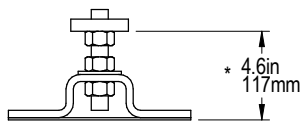
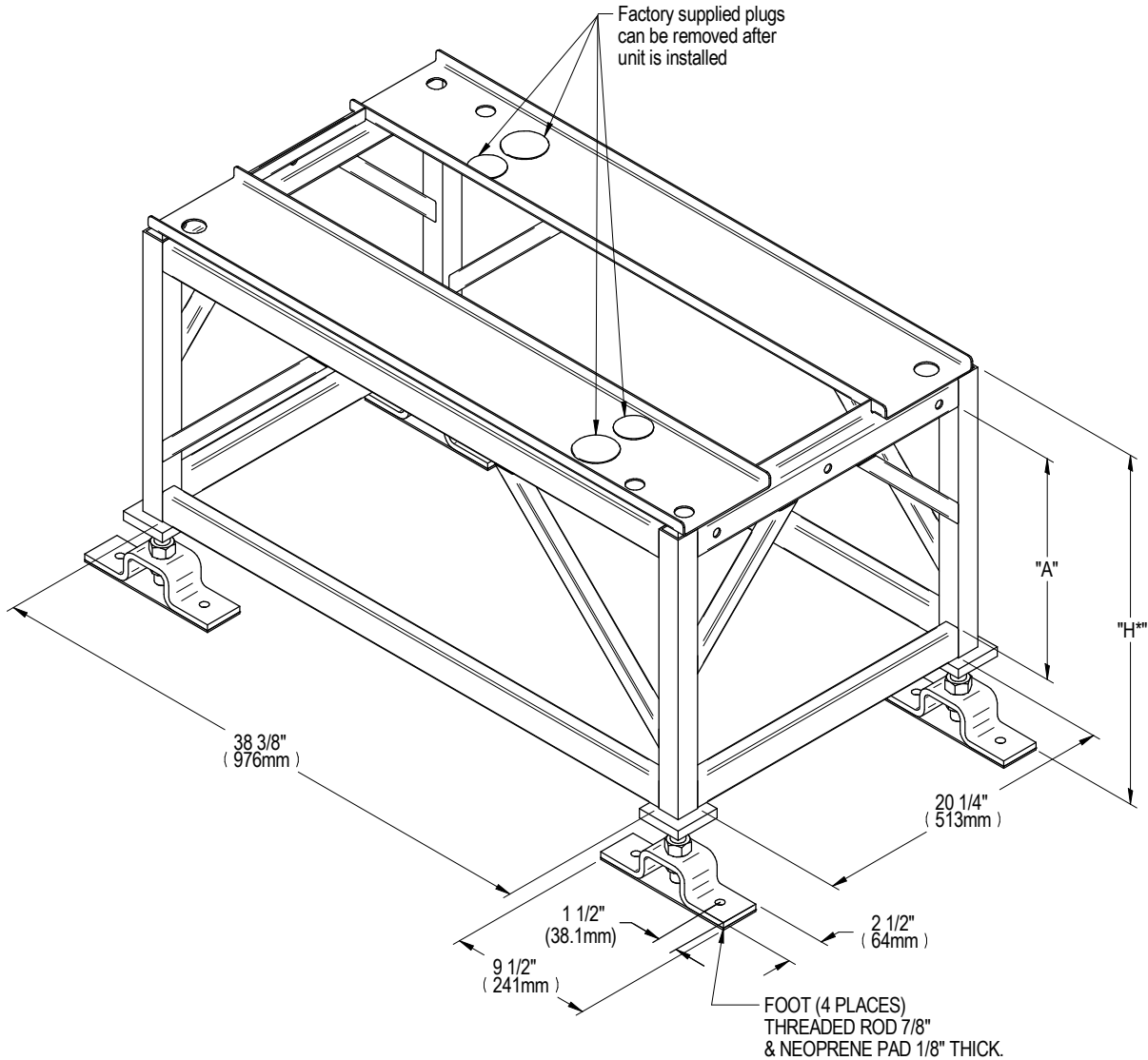

**Foot Detail**

* NOMINAL	in (mm)		in (mm)	
	* H		A	
12	12	305	8 3/4	222
18	18	457	14 3/4	375
24	24	610	20 3/4	527

\* Foot provides ±0.25in (6.4mm) of adjustment from nominal height H

**DIMENSIONAL DATA**  
**FLOORSTAND 600mm (24in.) MODELS**

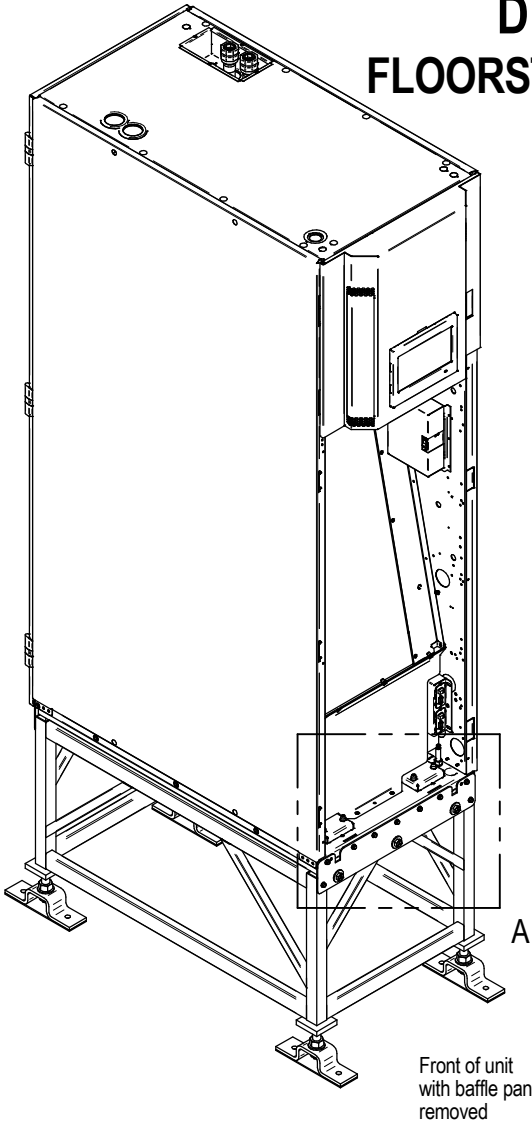

Front of unit  
with baffle panel  
removed

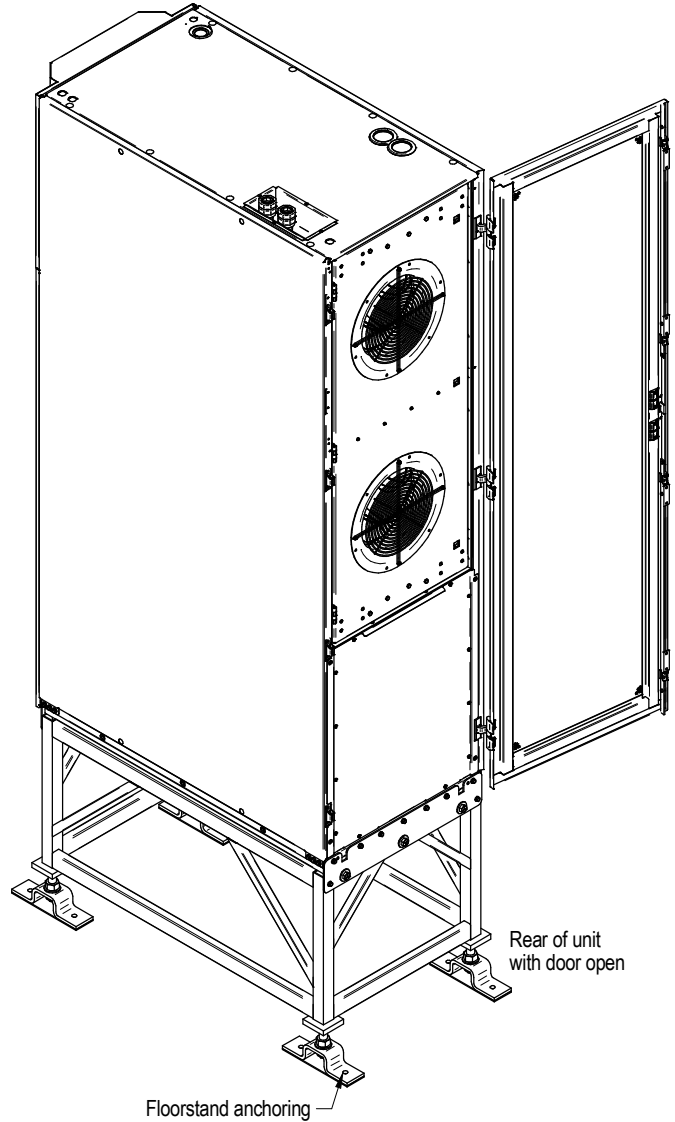

Rear of unit  
with door open

Floorstand anchoring

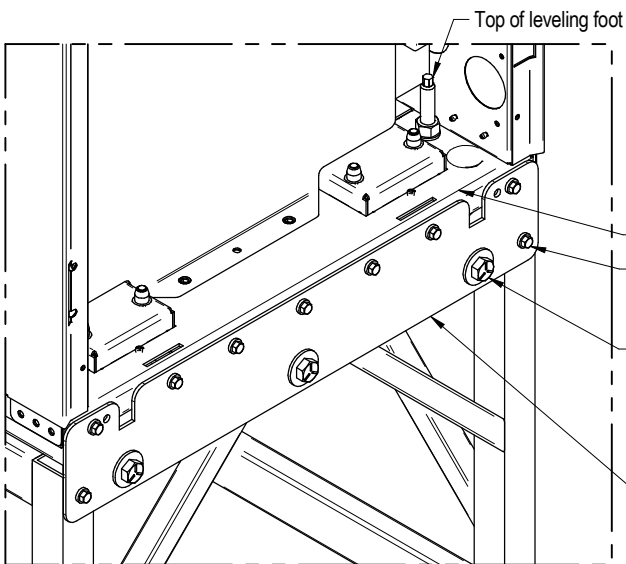

**DETAIL A**

- Top of leveling foot
- Base of unit
- 1/4-14 self drill screws  
supplied, 10 PLACES.
- 1/2-13 bolts,  
nuts & washers supplied.  
Align holes in bracket  
with holes in floorstand,  
3 PLACES.
- Bracket supplied  
front & rear

**Notes:**

- 1.) To level the unit lower the four stabilizing feet until they make contact with the floorstand. (SEE DETAIL "A")
- 2.) Anchor the bracket to the unit and the floorstand using the screws that are provided (SEE DETAIL "A").
- 3.) The same mounting bracket is used in the front and rear of the unit.
- 4.) This document is not to be used for field installation, see Liebert® CRV manual.

## DIMENSIONAL DATA

### 300mm (12in.) RIGID FLOOR MOUNT BRACKET

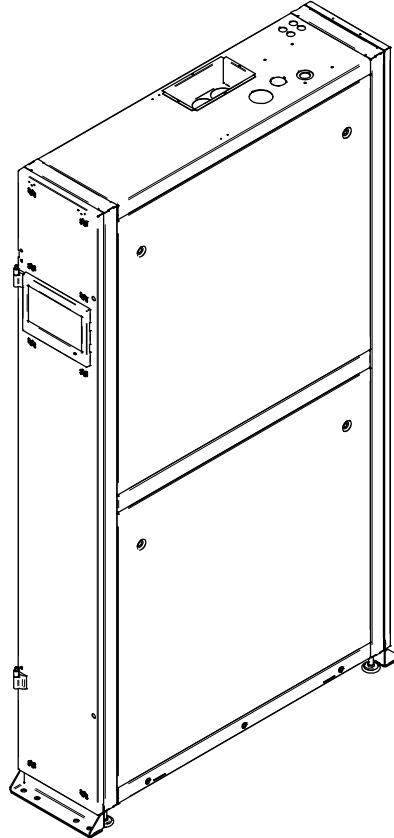

ISO VIEW ON FLOOR

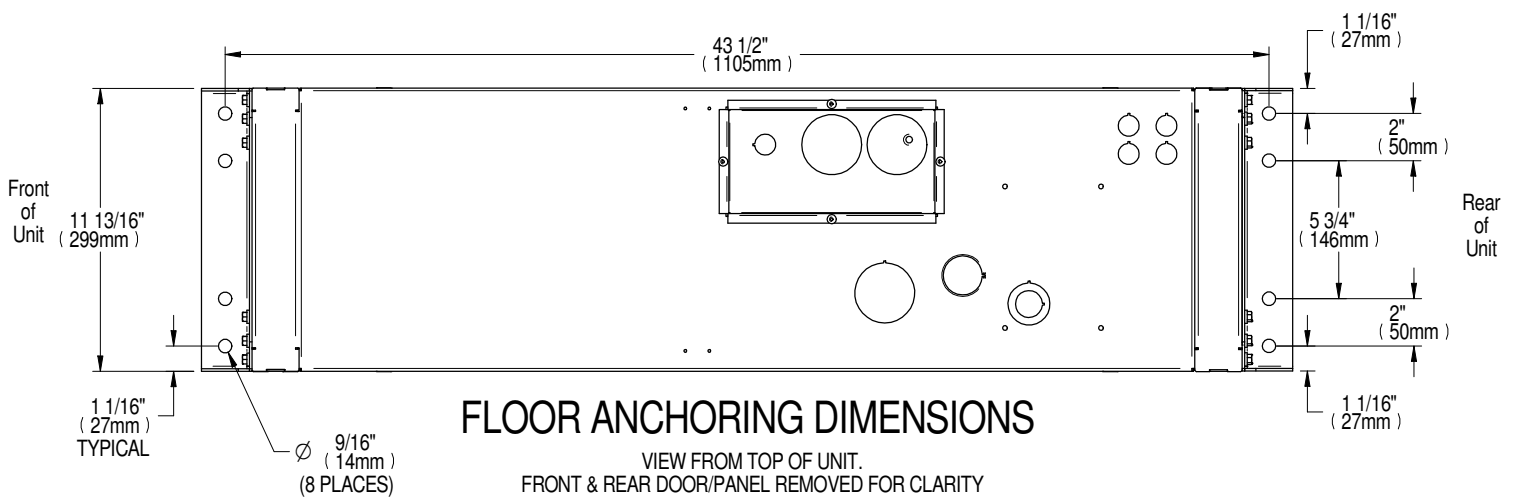

## ANCHORING DATA

### 300mm (12in.) RIGID FLOOR MOUNT BRACKET

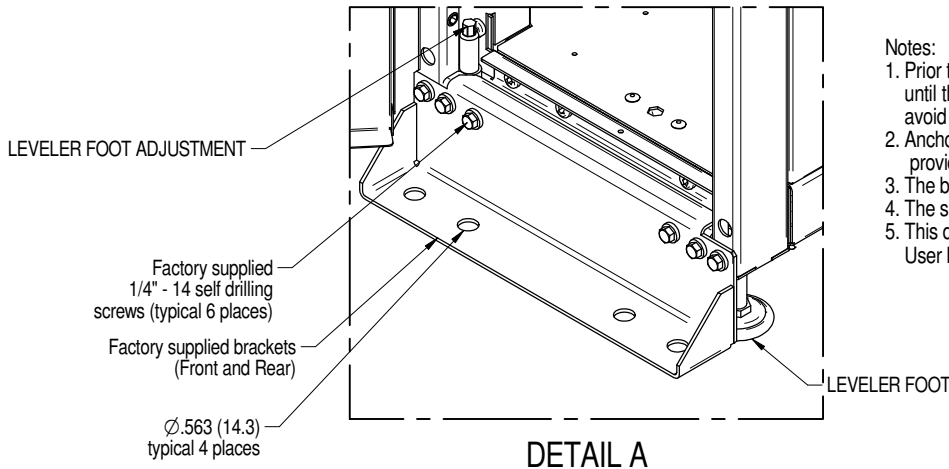
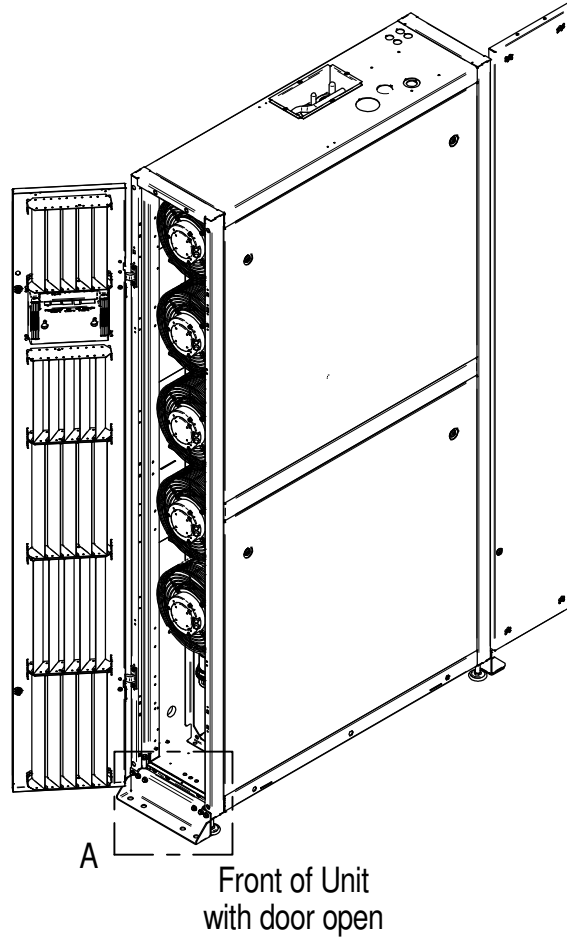

Notes:

1. Prior to mounting brackets, lower the four leveling feet (See Detail "A") until they make contact with the floor. Ensure that the unit is level to avoid corrosion or health hazards caused by condensate accumulation.
2. Anchor the brackets to the unit using the screws that are provided.
3. The brackets are to be secured to the floor using field supplied anchors.
4. The same mounting brackets are used in the front and rear of the unit.
5. This document is not to be used for field installation. See Liebert CRV User Manual.

**FLOORSTAND DIMENSIONAL DATA**  
**300mm (12in.) MODELS**

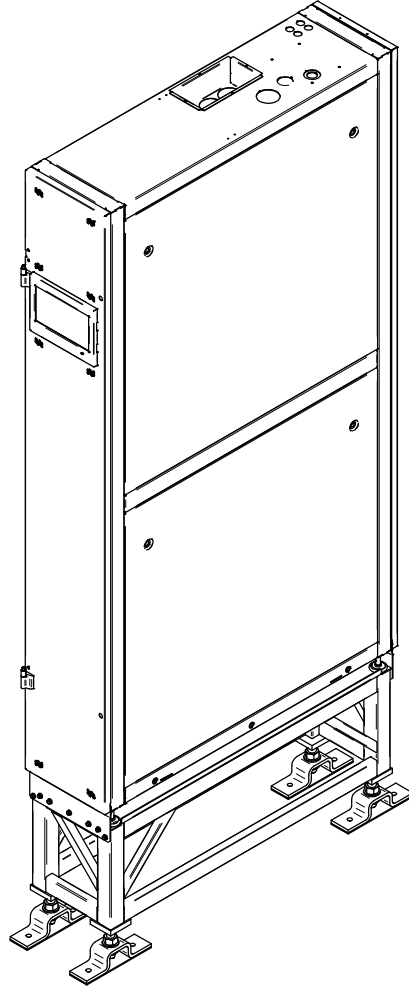

ISO VIEW WITH FLOORSTAND

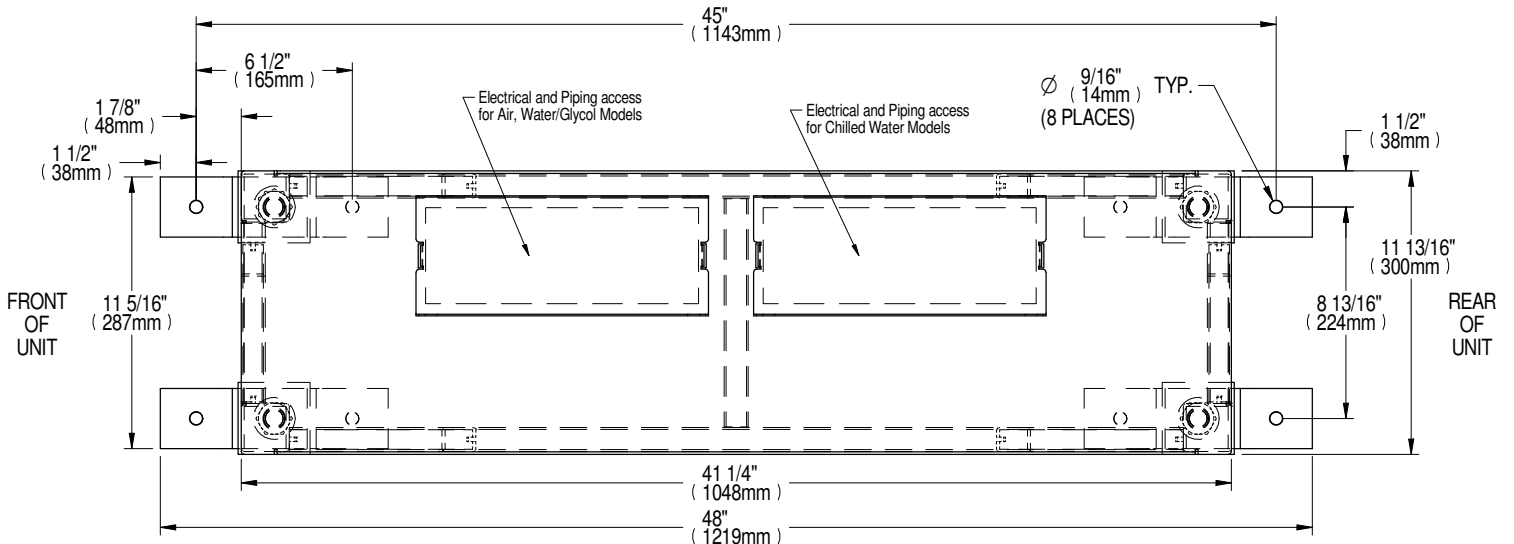

FLOORSTAND AND ANCHORING DIMENSIONS TOP VIEW OF UNIT



**FLOORSTAND DIMENSIONAL DATA**  
**300mm (12in.) MODELS**

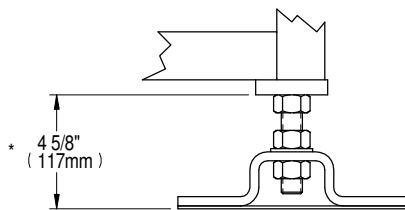
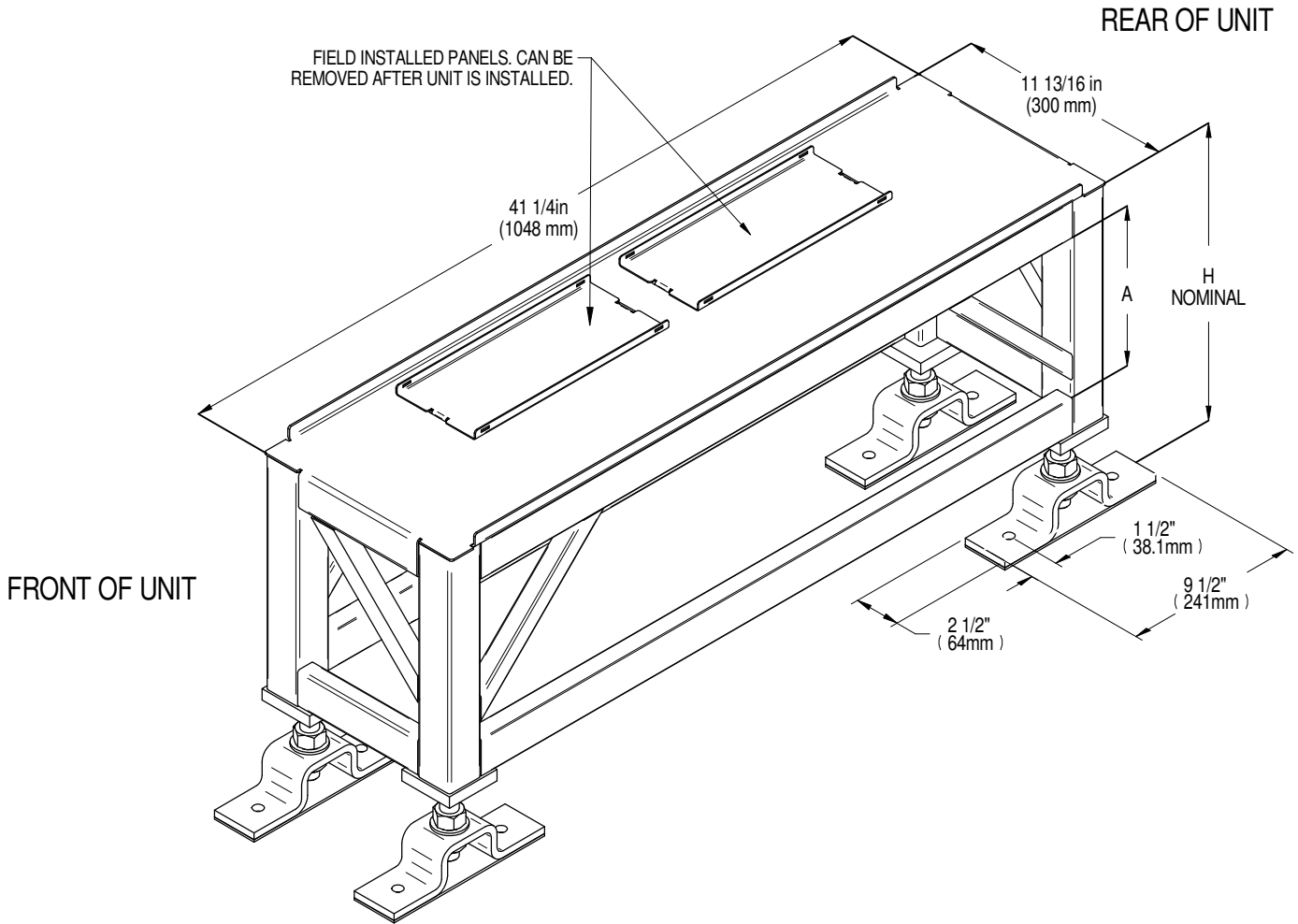

**FOOT DETAIL**

* NOMINAL	in (mm)		in (mm)	
	* H		A	
12	12	305	8 3/4	222
18	18	457	14 3/4	375
24	24	610	20 3/4	527

\* Foot provides ±0.25 in (6.4mm) adjustment from nominal height H.

**FLOORSTAND DIMENSIONAL DATA**  
**300mm (12in.) MODELS**

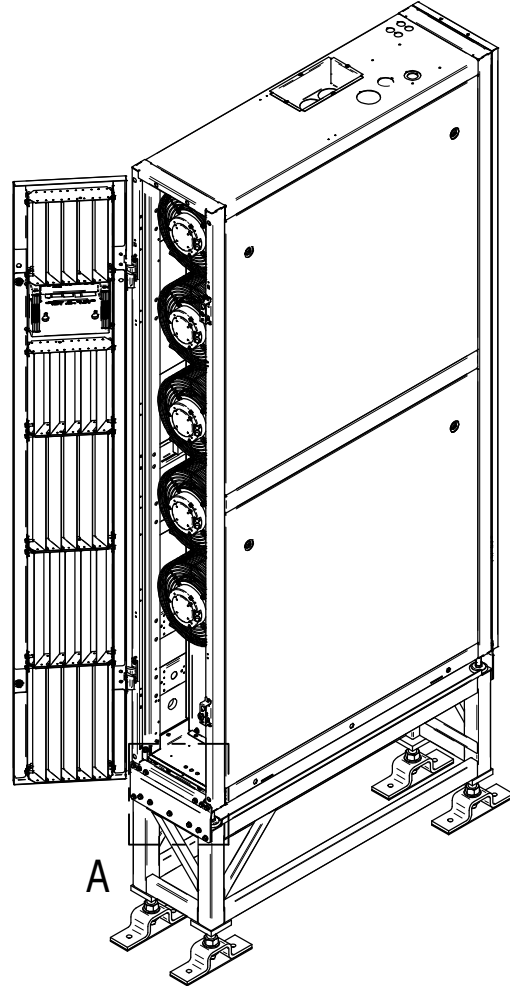

Front View of Unit  
with front door open

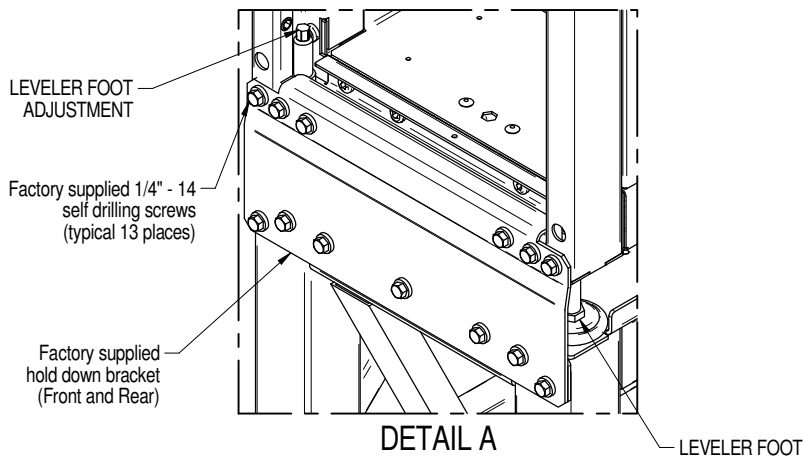

Notes:

1. Prior to mounting brackets, lower the four leveling feet (See Detail "A") until they make contact with the floor. Ensure that the unit is level to avoid corrosion or health hazards caused by condensate accumulation.
2. Anchor the brackets to the unit using the screws that are provided.
3. The brackets are to be secured to the floorstand using factory supplied screws.
4. The same mounting brackets are used in the front and rear of the unit.
5. This document is not to be used for field installation. See Liebert® CRV User Manual.

## CABINET ANCHOR DIMENSIONAL & GENERAL DATA

### 1-4 FAN MODELS

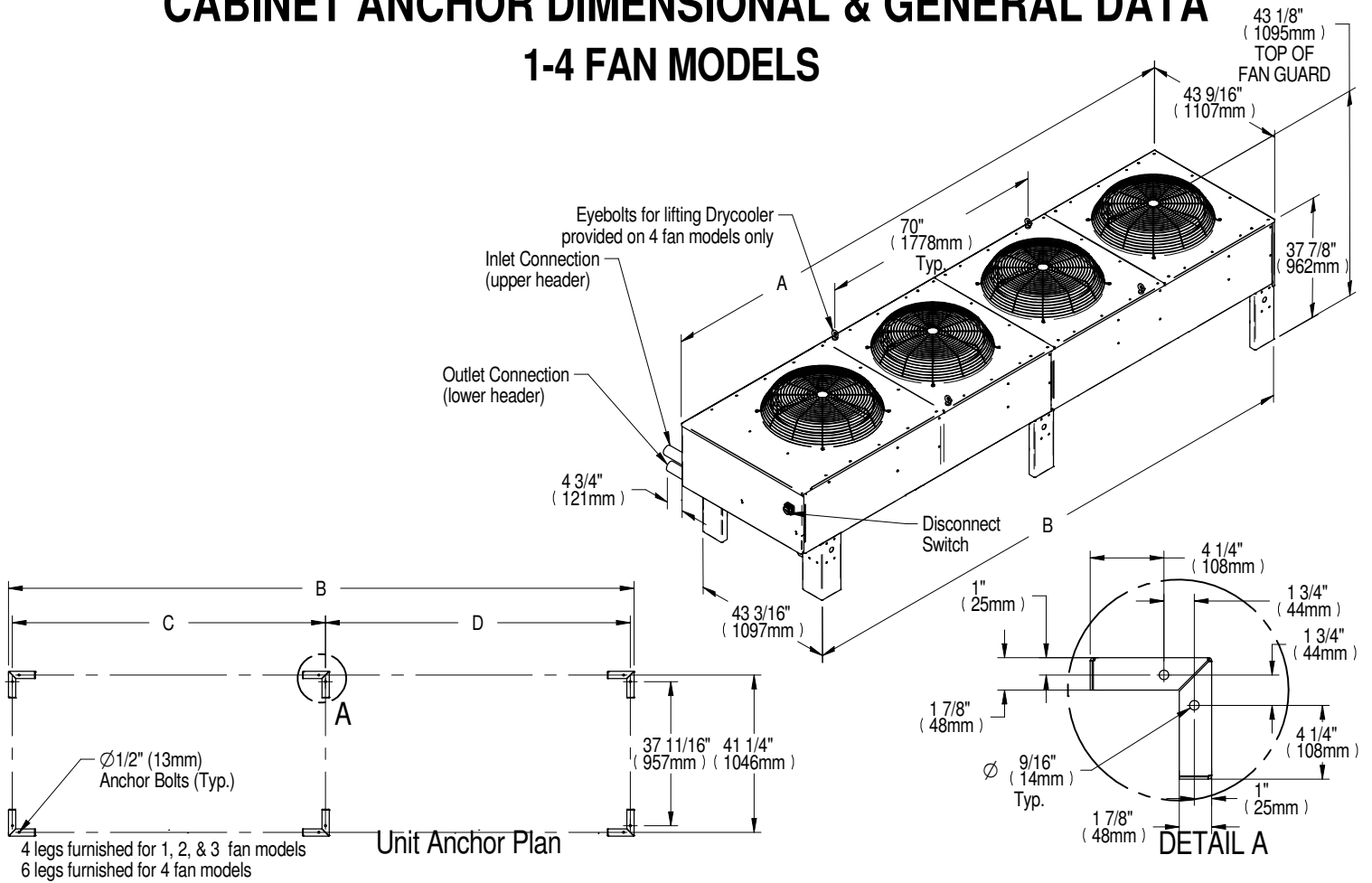

Liebert® Model	No. of fans	A in. (mm)	B in. (mm)	C in. (mm)	D in. (mm)	CFM (l/s)		Internal Volume Gal. (Liters)	Dry Wt. Lbs. (kg)
						60Hz (See note 1)	50Hz (See note 1)		
*D**033	1	51-1/2 (1308)	44 (1118)	42 (1067)	N/A	7200 (3398)	6000 (2932)	1.2 (4.6)	355 (161)
*D**069						6866 (3240)	5722 (2700)	2.4 (9.2)	375 (170)
*D**092						6633 (3130)	5527 (2609)	3.7 (13.9)	395 (179)
*D**109						6322 (2984)	5268 (2486)	4.9 (18.6)	415 (188)
*D**112						6088 (2873)	5074 (2394)	5.8 (22)	435 (197)
*D**139	2	91-1/2 (2324)	84 (2134)	82 (2083)	N/A	13732 (6481)	11443 (5401)	4.8 (18.2)	500 (227)
*D**174						13265 (6261)	11054 (5217)	6.9 (26.2)	540 (245)
*D**197						12645 (5968)	10535 (4973)	9 (34)	580 (263)
*D**225						12177 (5748)	10147 (4789)	11.1 (42.1)	620 (281)
*D**260	3	131-1/2 (3340)	124 (3150)	122 (3099)	N/A	19898 (9392)	16582 (7827)	10 (37.8)	735 (333)
*D**310						18965 (8951)	15804 (7459)	13.1 (49.6)	795 (361)
*D**350						17398 (8212)	14499 (6843)	19.4 (73.3)	855 (388)
*D**352	4	171-1/2 (4356)	164 (4166)	82 (2083)	80 (2032)	24800 (11705)	20667 (9755)	13.1 (49.6)	940 (426)
*D**419						23650 (11163)	19708 (9302)	17.4 (65.9)	1020 (463)
*D**466						22770 (10747)	18975 (8956)	22 (83.3)	1050 (476)
*D**491						21700 (10242)	18083 (8535)	26.3 (99.6)	1100 (499)

**Notes:**

- All Liebert® Drycooler motors are 3/4H.P.
- A minimum clearance of 36" (914mm) is recommended on all sides for proper operation and component access.

# LIEBERT® DRYCOOLER

## PIPING CONNECTIONS

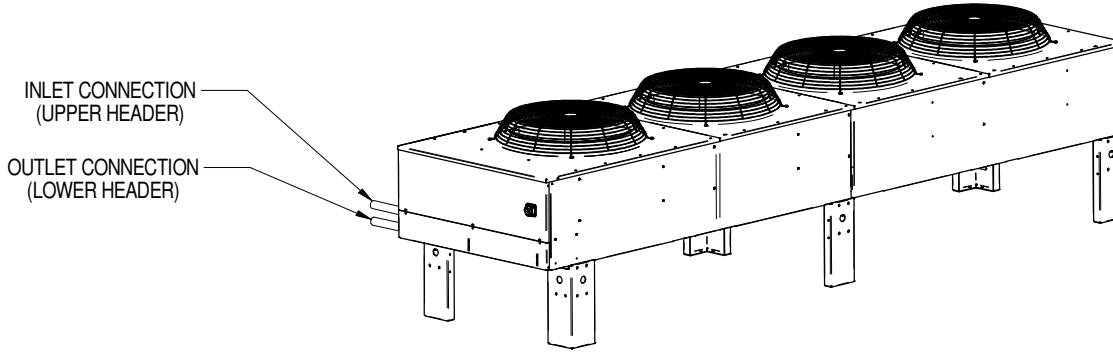

LIEBERT® DRYCOOLER PIPING CONNECTION SIZES (O.D. Cu)		
LIEBERT® DRYCOOLER MODEL NUMBER	NUMBER OF COIL CIRCUITS	INLET & OUTLET PIPE DIAMETER (INCHES)
-033	4*	1 3/8
-069	4, 8*	1 3/8
-092	6, 12*, 16	1 5/8
-109	8	1 3/8
-109	16*	2 1/8
-112	8	1 3/8
-112	16*, 26	2 1/8
-139	8, 16*	2 1/8
-174	8, 16*, 24	2 1/8
-197	8	1 3/8
-197	16*, 32	2 1/8
-225	16, 26*	2 1/8
-260	16, 24*	2 1/8
-310	16, 32*	2 1/8
-350	16, 32*	2 1/8
-350	48	2 5/8
-352	16, 24*	2 1/8
-419	16, 32*	2 1/8
-466	26	2 1/8
-466	40*	2 5/8
-491	16, 32	2 1/8
-491	48*	2 5/8







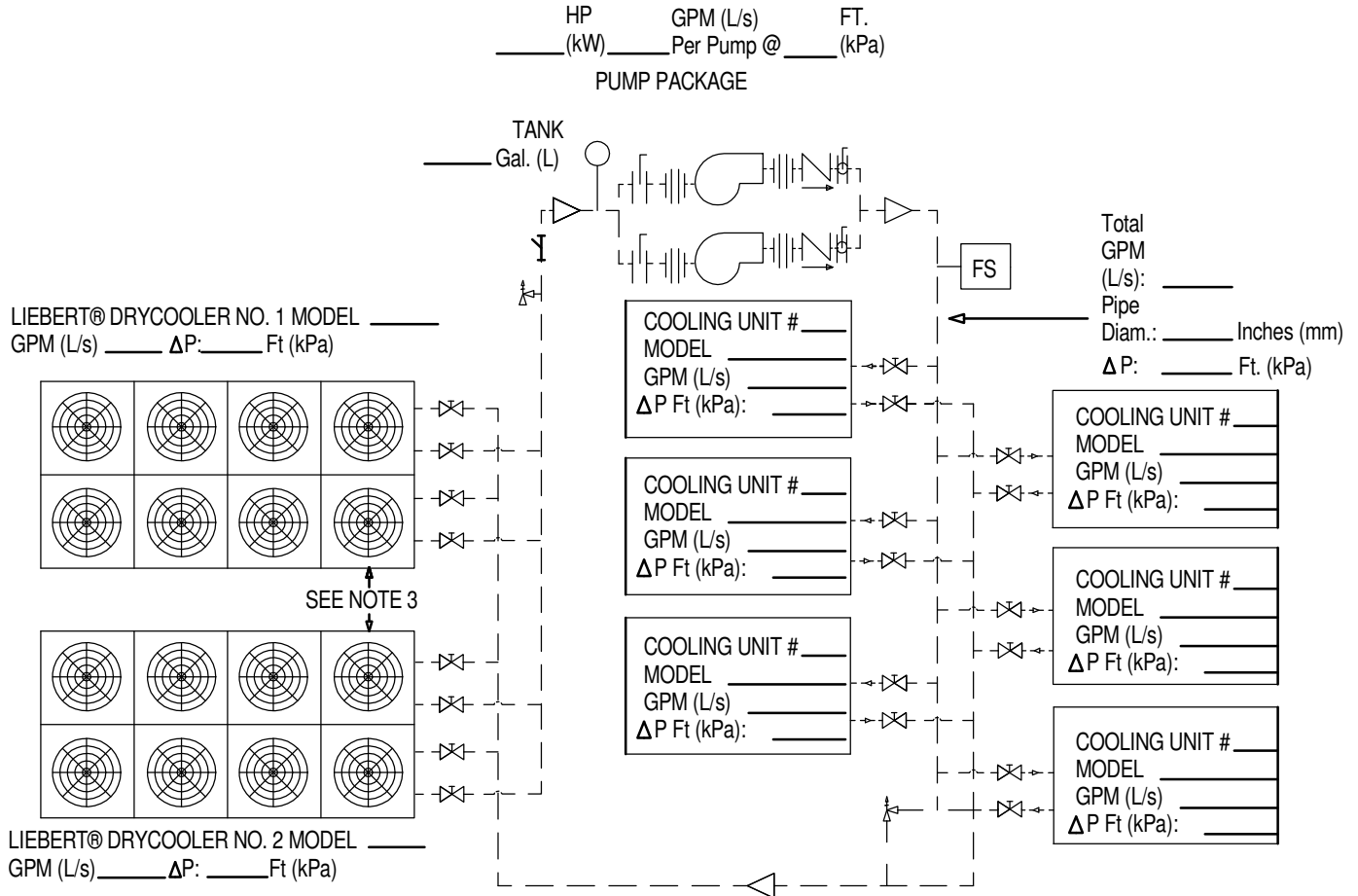

\* = Standard Circuiting

## PIPING SCHEMATIC

### MULTIPLE DRYCOOLERS & COOLING UNITS ON COMMON GLYCOL LOOP



**LEGEND**

-  GATE VALVE
-  CHECK VALVE
-  BUTTERFLY VALVE
-  RELIEF VALVE
-  UNION
-  BALL OR FLOW CONTROL VALVE
-  FLOW SWITCH
- $\Delta P$ : PRESSURE DROP
-  STRAINER/FILTER

**NOTES:**

1. PRESSURE AND TEMPERATURE GAUGES (OR PORTS FOR SAME) ARE RECOMMENDED TO MONITOR COMPONENT PRESSURE DROPS AND PERFORMANCE.
2. FLOW MEASURING DEVICES, DRAIN AND BALANCING VALVES TO BE SUPPLIED BY OTHERS AND LOCATED AS REQUIRED.
3. SEE PRODUCT LITERATURE FOR INSTALLATION GUIDELINES AND CLEARANCE DIMENSIONS.
4. DRAWING SHOWS DUAL PUMP PACKAGE. ALTERNATE PUMP PACKAGES WITH MORE PUMPS MAY BE CONSIDERED, CONSULT SUPPLIER.
5. DEPENDING ON THE LIEBERT® DRYCOOLER COIL CIRCUITING IT MAY HAVE 2 IN/OUT OR 4 IN/OUT CONNECTION POINTS.
6. INSTALL EXPANSION OR COMPRESSION TANK AT THE HIGHEST POINT OF THE SYSTEM.



# LIEBERT® DRYCOOLER

## ELECTRICAL FIELD CONNECTIONS FLUID TEMPERATURE CONTROL

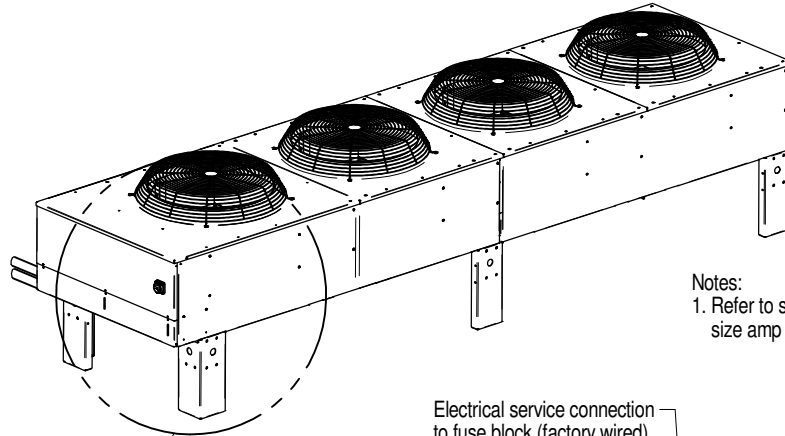

Notes:  
1. Refer to specification sheet for full load amp and wire size amp ratings.

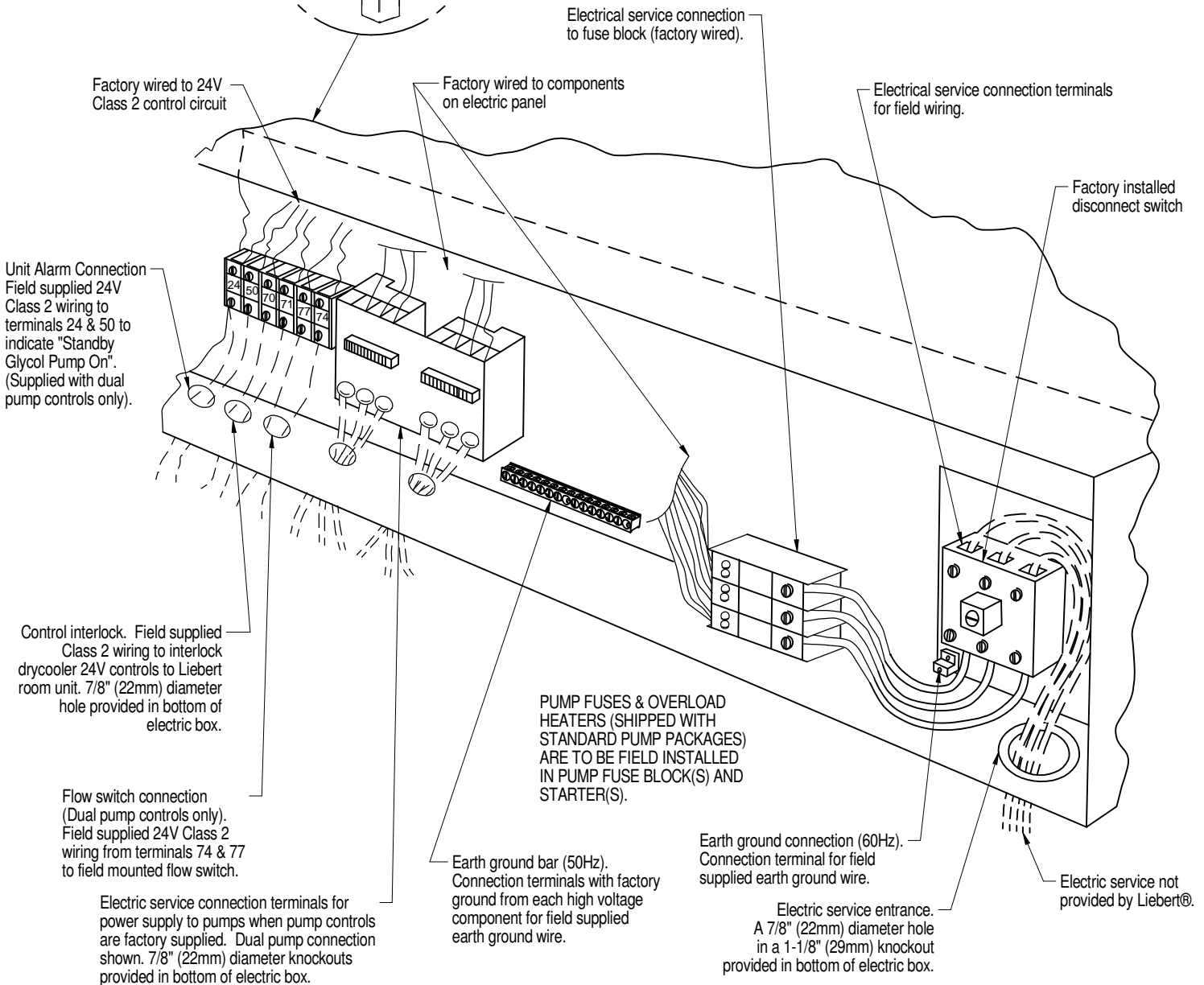

Form No.: DPN001040\_REV14



# LIEBERT® DRYCOOLER

## ELECTRICAL & PIPING CONNECTION DATA PUMP PACKAGE

GLYCOL PUMP DATA							
HP	ELECTRICAL DATA 60Hz					PIPING CONNECTIONS NPT FEMALE IN.	
	PHASE	FLA (FULL LOAD AMPS)				SUCTION	DISCHARGE
		208V	230V	460V	575V		
3/4	1	7.6	6.9	N/A	N/A	1-1/4	3/4
1-1/2	3	3.5	3.2	1.6	1.3		
2		6.6	6.0	3.0	2.4		
3		7.5	6.8	3.4	2.7		
5		10.6	9.6	4.8	3.9	1-1/2	1
7.5		16.7	15.2	7.6	6.1		1-1/4
		24.2	22	11	9	3	3
HP	ELECTRICAL DATA 50Hz					PIPING CONNECTIONS NPT FEMALE IN.	
	PHASE	FLA (FULL LOAD AMPS)				SUCTION	DISCHARGE
		380V / 415V					
1	3	1.64 / 1.63				1-1/4	3/4
1-1/2		2.4 / 2.25					
2		3.00 / 2.88					
3		4.7 / 4.38				1-1/2	1-1/4
5		7.9 / 7.47					

## PIPING LOCATIONS & DIMENSIONAL DATA SINGLE PUMP PACKAGE

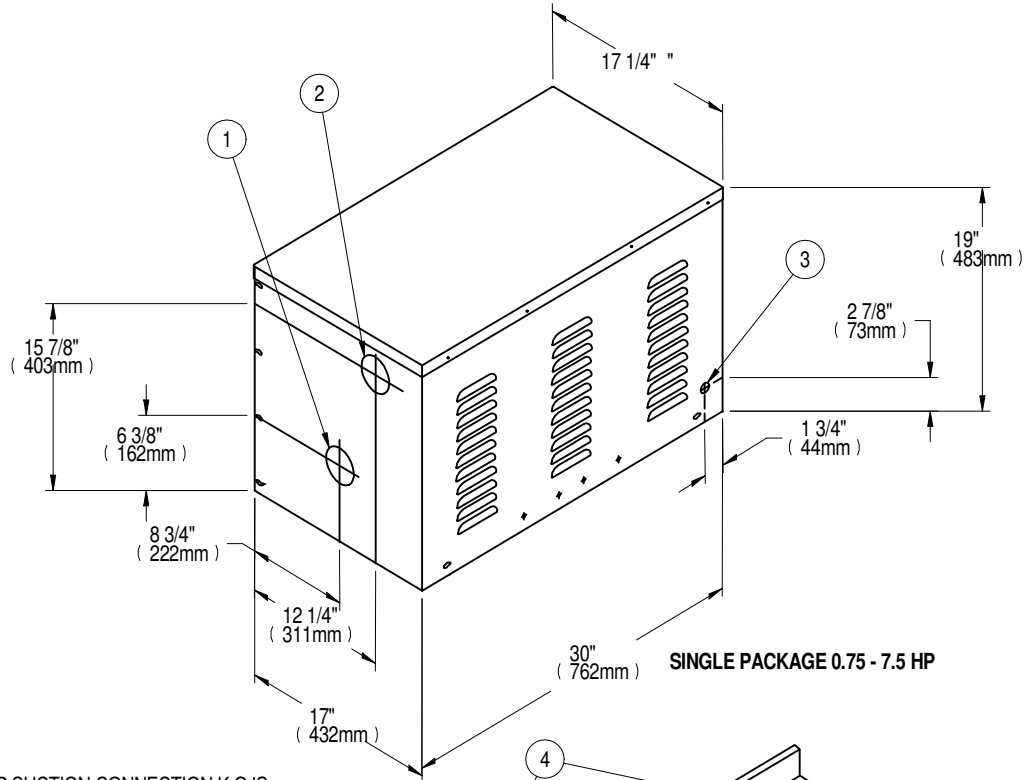

**SINGLE PACKAGE 0.75 - 7.5 HP**

- ① 3" (76.2mm) DIA. PUMP SUCTION CONNECTION K.O.'S
- ② 3" (76.2mm) DIA. PUMP DISCHARGE CONNECTION K.O.'S
- ③ 7/8" (22.2mm) DIA. ELECTRICAL K.O.'S
- ④ 1/2" (12.7mm) DIA. HOLES FOR MOUNTING

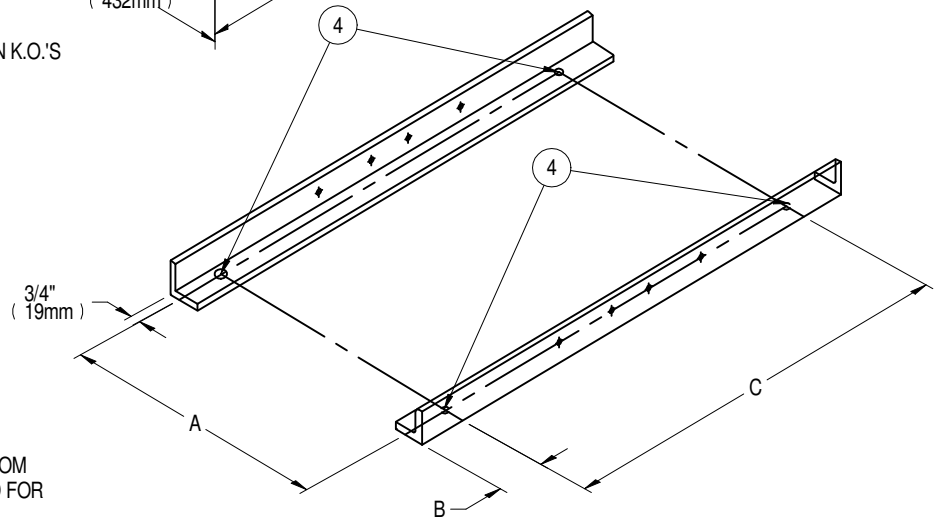

**PUMP PACKAGE MOUNTING ANGLES**

NOTE:  
ANGLES LOCATED INSIDE, BOTTOM  
OF PUMP PACKAGE. VIEW USED FOR  
MOUNTING REFERENCE.

MOUNTING HOLE DIMENSIONAL DATA in. (mm)			
Pump Package	A	B	C
Single (0.75 - 7.5HP)	15-1/4 (387)	2-1/2 (64)	22-1/2 (572)

SINGLE PUMP PACKAGE WEIGHT, lb (kg)	
Model	Weight
S.75	64 (29)
S1.5	66 (30)
S2	
S3	90 (41)
S5	121 (55)
S7.5	152 (69)



## GENERAL ARRANGEMENT DIAGRAM & DIMENSIONAL DATA EXPANSION TANK FOR GLYCOL/GLYCOOL SYSTEMS

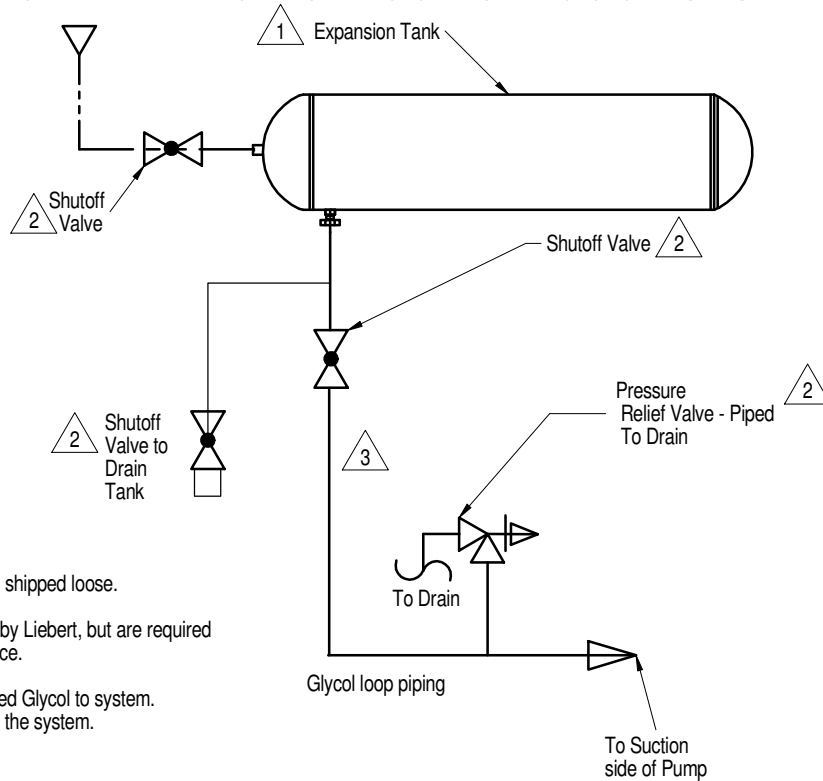

Notes:

- 1. These components are factory supplied and shipped loose. Field installation and piping by others.
- 2. These components are not factory supplied by Liebert, but are required for proper system operation and maintenance. Field installation and piping by others.
- 3. Field to provide a means for adding pre-mixed Glycol to system.
- 4. Install expansion tank at the highest point of the system.

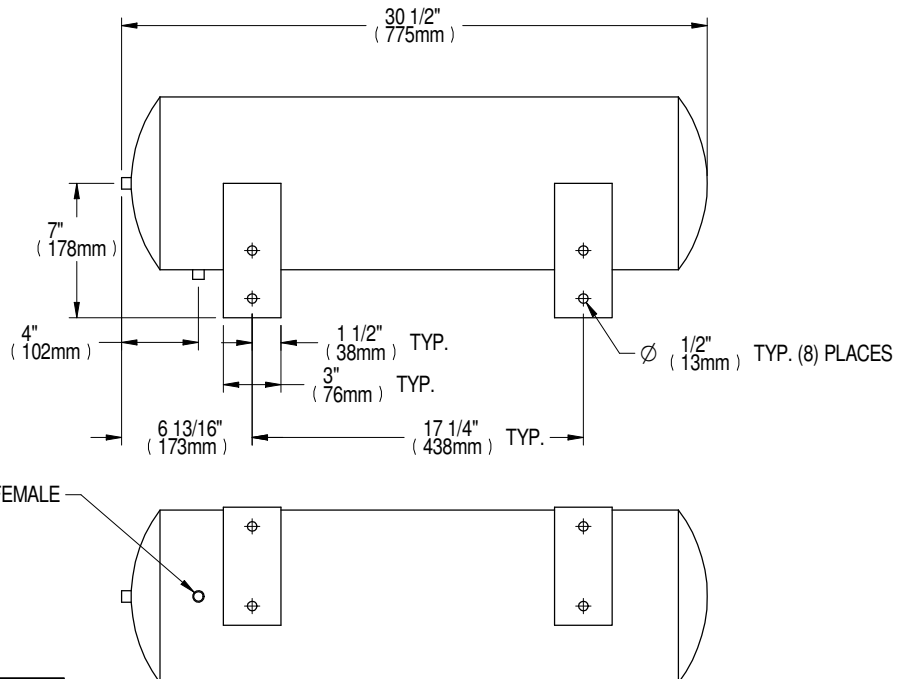
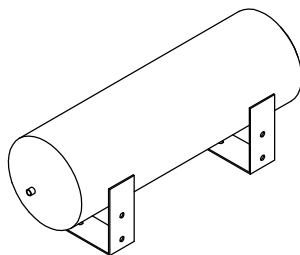
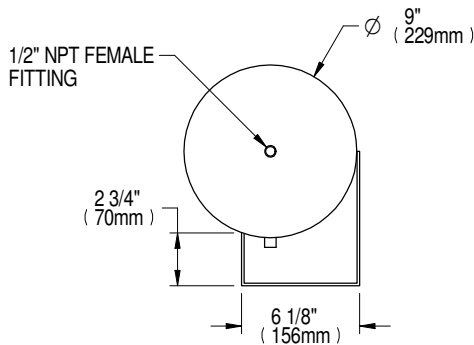

Expansion Tank Volume Gal (L)	Approx. Dry Weight lbs. (kg)	Maximum System Volume Gal (L)	
		Open System	Closed System
Tank Only			
8.8 (33.3)	26 (11.8)	75 (280)	140 (530)

## GENERAL ARRANGEMENT DIAGRAM & DIMENSIONAL DATA ASME COMPRESSION TANK KITS GLYCOL/GLYCOOL SYSTEMS

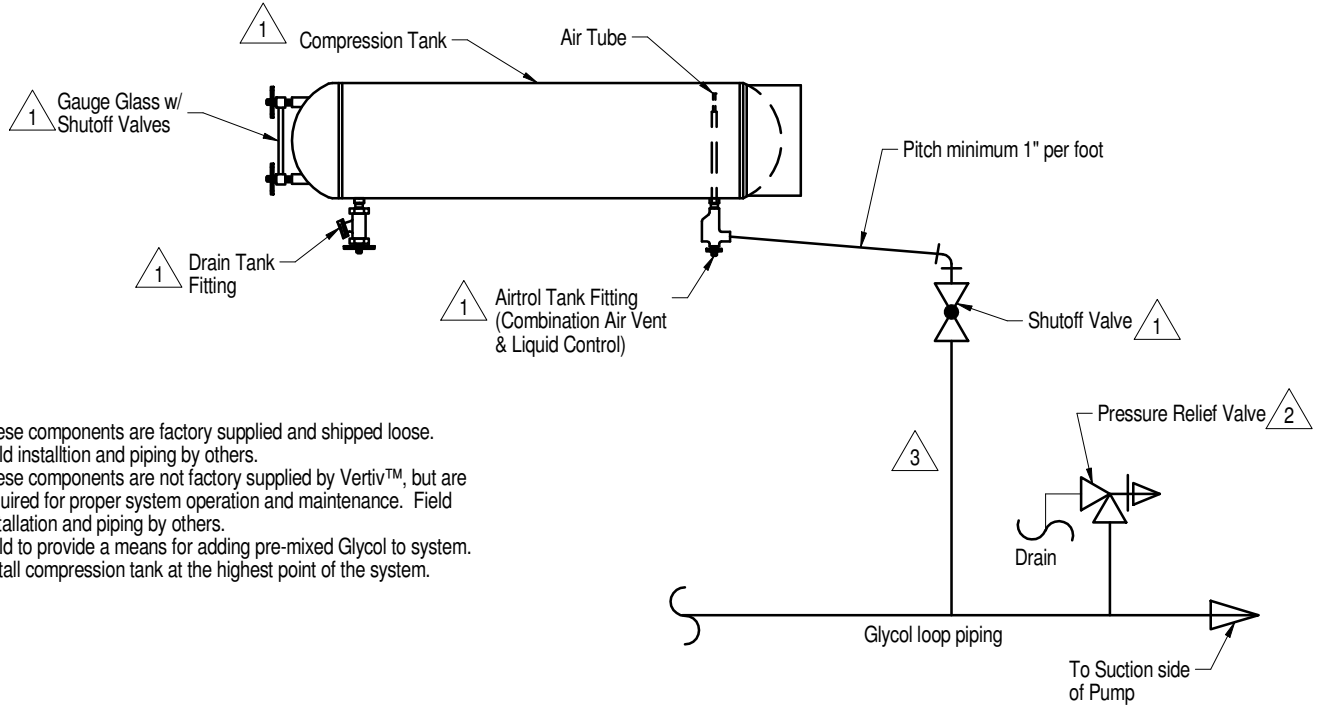

Notes:

1. These components are factory supplied and shipped loose. Field installation and piping by others.
2. These components are not factory supplied by Vertiv™, but are required for proper system operation and maintenance. Field installation and piping by others.
3. Field to provide a means for adding pre-mixed Glycol to system.
4. Install compression tank at the highest point of the system.

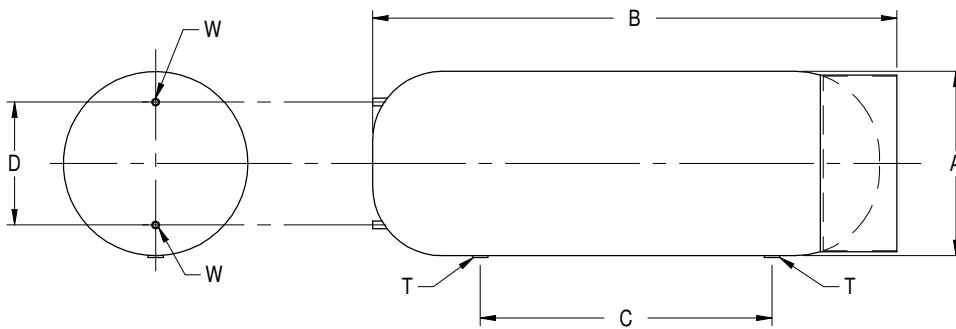

MAXIMUM SYSTEM (GAL)	TANK CAPACITY (GAL)	DIMENSIONS in. (mm)						APPROX. KIT WT. Lbs. (kg)
		A	B	C	D	T (NPT Female)	W (NPT Female)	
250	15	12 (305)	34-1/8 (867)	19 (483)	8 (203)	1"	1/2"	60 (27.2)
400	24		52-1/8 (1324)	37 (940)				75 (34.0)
500	30	14 (356)	49-3/8 (1254)	31-1/4 (794)	10 (254)	1"	1/2"	82 (37.2)
650	40		64-3/8 (1635)	46-1/4 (1175)				105 (47.6)
1000	60	16 (406)	73 (1854)	53-1/2 (1359)	12 (305)	1"	1/2"	140 (63.5)
1650	100	20 (508)	80-5/16 (2040)	58 (1473)	16 (406)	1"	1/2"	200 (90.7)

### **Connect with Vertiv on Social Media**



<https://www.facebook.com/vertiv/>



<https://www.instagram.com/vertiv/>



<https://www.linkedin.com/company/vertiv/>



<https://www.twitter.com/Vertiv/>



---

Vertiv.com | Vertiv Headquarters, 1050 Dearborn Drive, Columbus, OH, 43085, USA

© 2022 Vertiv Group Corp. All rights reserved. Vertiv™ and the Vertiv logo are trademarks or registered trademarks of Vertiv Group Corp. All other names and logos referred to are trade names, trademarks or registered trademarks of their respective owners. While every precaution has been taken to ensure accuracy and completeness here, Vertiv Group Corp. assumes no responsibility, and disclaims all liability, for damages resulting from use of this information or for any errors or omissions. Specifications, rebates and other promotional offers are subject to change at Vertiv's sole discretion upon notice.

SL-11978\_REV16\_10-22