



Liebert® PST4™ 660 – 850 VA

Installer/User Guide

DISCONTINUED

DISCONTINUED

Technical Support Site

If you encounter any installation or operational issues with your product, check the pertinent section of this manual to see if the issue can be resolved by following outlined procedures. For additional assistance, visit <https://www.VertivCo.com/en-us/support/>

TABLE OF CONTENTS

1 Liebert PST4 Overview	5
1.1 Controls and Indicators	6
1.2 Installation	6
1.3 Setup and Start-up	7
1.4 UPS Operation	7
1.5 Alarms	8
1.5.1 On Battery	8
1.5.2 Low Battery Warning	8
1.5.3 Weak/Bad Battery	8
1.5.4 Overload	8
1.5.5 UPS Fault	8
1.6 Troubleshooting	9
1.7 Maintenance and Battery Replacement	9
1.7.1 Battery Charging	9
1.7.2 Precautions	9
1.7.3 Battery Replacement Precaution	10
1.7.4 Information for the Protection of the Environment	10
1.7.5 Battery Replacement Procedure	10
1.7.6 Specifications	12
Appendices	15
Appendix 1: Technical Support	15

DISCONTINUED

DISCONTINUED

1 LIEBERT PST4 OVERVIEW

Thank you for purchasing the Liebert PST4 Uninterruptible Power Supply. It is designed, manufactured, and tested to provide many years of reliable power protection.

Please review this manual and the important safety instructions before installing, operating, or maintaining your Liebert PST4 UPS.



CAUTION: Connect the UPS only to a properly grounded/earthed outlet that is protected by an appropriate branch circuit protector (circuit breaker or fuse) that meets national and/or local electrical codes.

The Liebert PST4 should be located near the wall outlet. Do not use extension cords between the wall outlet and the UPS. The Liebert PST4 is designed for small office and home use only. It is not recommended to be used with life-support equipment or applications.



WARNING: Risk of Electric Shock. Observe all cautions and warnings in this manual. Failure to do so may result in serious injury or death. Refer all UPS and battery service to properly trained and qualified service personnel. Do not attempt to service this product yourself beyond the battery replacement procedures. Opening or removing the cover may expose you to lethal voltages within this unit even when it is apparently not operating and the input wiring is disconnected from the electrical source. Never work alone.

In case of fire, use a dry chemical fire extinguisher to put out the fire. Using a fluid fire extinguisher may cause electric shock. In the event of an emergency, press and hold the ON/OFF button for at least one (1) second to turn off the UPS then unplug the UPS from the wall outlet.

NOTICE: This equipment has been tested and found to comply with the limits for a Class B computing device in accordance with the specifications in Subpart J of Part 15 of FCC Rules and also meets the Class B limits for radio noise emissions from digital apparatus set out in the Radio Interference of the Canadian Department of Communications. These limits are designed to provide reasonable protection against such interference in a residential installation. This equipment generates and uses radio frequency and if not installed and used properly, that is, in strict accordance with the manufacturer's instructions, this equipment may cause interference to radio and television reception. If this equipment does cause interference to radio or television reception, which can be determined by turning the equipment off and on, the user is encouraged to try to correct the interference by one or more of the following measures:

- Re-orient the receiving antenna.
- Relocate the computer with respect to the receiver.
- Move the computer away from the receiver.
- Shielded communication-interface cables must be used with this product.



WARNING: Changes or modifications to this unit not expressly approved by the party responsible for compliance could void the user's authority to operate the equipment.

The Liebert PST4 is shipped with the following items:

- CD with Liebert MultiLink® Shutdown Software and User manual (electronic version)
- USB cable; one 2 m (6-1/2 ft.) long
- Coax cable; one 1 m (3 ft.) long
- Wall-mount template and screws
- User Manual with warnings safety instructions and WEEE recycling sheet (ISO 14001 compliance)

1.1 Controls and Indicators

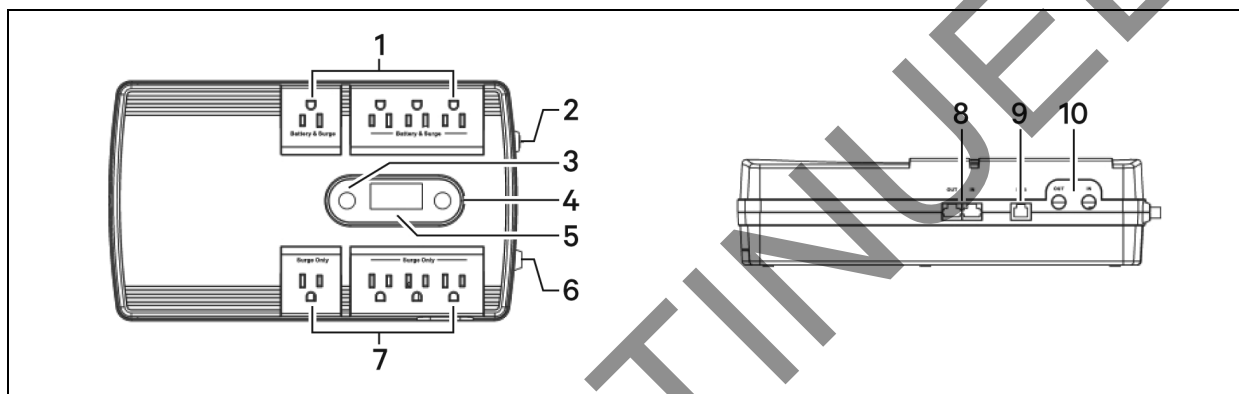

ITEM	DESCRIPTION
1	Battery-backed and surge-protected output power receptacles.
2	Input Circuit Breaker. The input circuit breaker trips in the event the output load exceeds the UPS's power rating.
3	Scroll button, to scroll through the LCD-display parameters and, when on battery power, can silence the audible alarm.
4	On/Off button.
5	LCD Display with icons and numerical information to display UPS status and operational parameters.
6	Input Power Cord.
7	Surge-protected-only output-power receptacles.
8	RJ11/45 connectors for phone/fax/modem or network surge protection.
9	RJ45 connector for USB communications port for UPS monitoring and control.
10	Coax Cable connections for cable modem, DSS receiver, or cable-TV converter surge protection.

1.2 Installation

Install the Liebert PST4 in a temperature-controlled environment that is free of corrosive and conductive contaminants. Avoid locations near heat or water sources and exposed to direct sunlight. For proper ventilation, leave approximately 2 to 4 inches clearance on all sides of the UPS.

The UPS unit ships with the internal battery connected.

The UPS may be mounted to a wall using the mounting slots on the bottom of the UPS and provided screws. A template for screw location is provided and the unit should be mounted ensuring they are in a wall stud for a secure installation.

1.3 Setup and Start-up

Inspect the UPS for any signs of obvious damage. If damage is visible, do not proceed with the setup and call our warranty support line for a new replacement unit.

The UPS has 4 battery-backed and surge-protected receptacles and 4 surge-protected-only receptacles. Plug your critical equipment (such as computer, monitors, etc.) into the battery-backed receptacles and your less-critical equipment (such as printers and other less-often used peripherals) into the surge-only receptacles.

If you also want to protect your computer network connection or telephone, you can use the network/telephone surge-protection ports on the side. Use the “IN” port to connect the line from the wall jack and the “OUT” port to connect to your device port. Use of this feature is not required for proper operation of the UPS.

If you also want to protect your cable modem, DSS Receiver, or cable-TV converter connection you can use the Coax surge protection ports on the side of the UPS. Use the “IN” port to connect the line from the wall jack and the “OUT” port to connect to your device port. Use of this feature is not required for proper operation of the UPS.

If you wish to use the USB communications, plug the provided cable into the port on the UPS and the other end into an open USB port on your computer. This allows unattended shutdown of your computer using either the built-in feature within the Microsoft® Windows® operating system or the Liebert Multilink® Shutdown software located on the CD that shipped with the UPS. Use of this feature is not required for proper operation of the UPS.

You are now ready to start the UPS. Plug the UPS input cord into the wall outlet. To turn on the UPS, press and hold the ON/OFF button until you hear the UPS beep, then release the button. The connected equipment immediately receives power and the UPS starts a short, self system test (electronics and battery check). When the unit passes all self checks, only the green LED should be lit indicating normal operation.

NOTE: While every precaution has been taken to ensure that the battery is in good condition, we recommend allowing the UPS to charge the battery for at least 4 hours prior to providing full back-up time protection for any utility-power abnormality.

1.4 UPS Operation

The UPS is designed for easy operation. Once the UPS is plugged into the wall outlet, it begins to charge the battery whether the UPS has been turned on or not.

To turn on the UPS, press and hold the ON/OFF button until the unit beeps, then release the button.

To turn off the UPS, press and hold the ON/OFF button for at least 1 second then release the button. To completely stop all UPS operation, once the UPS is turned off, unplug the input cord from the wall outlet.

During normal operation, the UPS protects the connected equipment from utility abnormalities, such as brownout/sags, over-voltage/surges, and complete outages. During these periods, the UPS automatically draws power from the battery to support the connected equipment that is plugged into the battery-backed outlets. Note that equipment plugged into the surge-only outlets shut down in these conditions. If the utility power problems are long-term, the UPS will eventually shut down because all battery power is exhausted. Once utility power is restored to normal operating parameters for the UPS, it automatically restarts and begins to power the connected equipment and to recharge the battery for the next utility abnormality.

1.5 Alarms

1.5.1 On Battery

When the UPS is operating on the batteries, the On Battery icon on the LCD panel illuminates and the audible alarm sounds once every 5 seconds. The alarm stops once the UPS returns to the AC normal mode.

1.5.2 Low Battery Warning

The UPS sounds 2 beeps every 5 seconds when the battery reserve runs low. This condition continues until AC returns or the UPS shuts down from battery exhaustion.

1.5.3 Weak/Bad Battery

The UPS automatically tests the battery's condition and, if the battery fails the test because of weak capacity, bad battery, or battery disconnected:

- The Battery Capacity bar graph on the LCD display flashes on/off
- The alarm beeps 3 times every 30 seconds until the battery is reconnected or replaced.

We recommend that the UPS charge overnight before performing a battery test to confirm a Weak/Bad Battery condition.

1.5.4 Overload

When the amount of equipment connected to the UPS exceeds its power rating, the Load Capacity bar graph on the LCD display flashes on/off, and the UPS sounds 1 beep every half second (AC and Battery modes). The alarm remains on until the excess load is removed or the UPS's self-protection circuit shuts down the UPS.

1.5.5 UPS Fault

When the UPS detects a hardware fault, the Fault icon on the LCD display illuminates and the UPS sounds a constant alarm. The fault condition, in some instances, may be reset by turning the UPS off and then back on.

DISCONTINUED

1.6 Troubleshooting

SYMPTOM	POSSIBLE CAUSE	WHAT TO DO
UPS will not turn on.	On/Off/ button not pressed.	Press and release the On/Off button to start UPS.
UPS operates in battery mode only, even though normal AC power is present.	Input AC circuit breaker is tripped.	Reset circuit breaker by pressing the plunger back in. If the AC circuit breaker trips after UPS starts up, reduce the load on the UPS.
Fault icon is illuminated.	UPS has detected an internal fault.	Call for a replacement unit.
The AC mode icon LED is illuminated, but there is no output.	The UPS is being controlled via its communications port.	Disconnect the computer cable from the UPS and press the On button. If UPS works normally, the software has control of the UPS. If the UPS still does not have output power, call for service.
UPS does not provide expected runtime.	The batteries may be weak or at the end of useful service life.	Charge the batteries for 8-hours and retest. If the run time is still less than expected, the batteries may need replaced, even though the Weak/ Bad Battery alarm is not sounding.
Battery Capacity bar graph is flashing on and off.	Loose connections at the batteries, Weak batteries, Bad batteries.	Check battery connections, charge the batteries for 8-hours, replace the batteries.
Load Capacity bar graph is flashing on and off.	The load has exceeded the UPS's capacity.	Check the "Specifications" on page 12 table that follows. Remove part of the load.

1.7 Maintenance and Battery Replacement

1.7.1 Battery Charging

The batteries are valve-regulated, non-spill-able, lead acid and should be kept charged to attain their design life. The Liebert PST4 charges the batteries continuously when it is connected to the utility input power. If the Liebert PST4 will be stored for a long time, we recommend connecting the UPS to input power for at least 24 hours every 4 to 6 months to ensure full recharge of the batteries.

1.7.2 Precautions

Although the Liebert PST4 is designed and manufactured to ensure personal safety, improper use can result in electrical shock or fire. To ensure safety, observe the following precautions:

- Turn off and unplug the UPS before cleaning it.
- Clean the UPS with a dry cloth. Do not use liquid or aerosol cleaners.
- Never block or insert any objects into the ventilation holes or other openings of the UPS.
- Do not place the UPS power cord where it might be damaged.

1.7.3 Battery Replacement Precaution

Before proceeding, please review the battery safety precautions.



WARNING: Risk of electric shock and explosion. Can cause equipment damage, injury and death. Do not dispose of the battery in a fire. The battery may explode. Do not open or damage the battery. Released electrolyte is toxic and is harmful to skin and eyes. If electrolyte comes into contact with the skin, wash the affected area immediately with plenty of clean water and get medical attention.



WARNING: Risk of electric shock. Can cause equipment damage, injury and death. A battery can present a risk of electrical shock and high short-circuit current. The following precautions should be observed when working on batteries:

- Remove watches, rings and other metal objects.
- Use tools with insulated handles. Wear rubber gloves and boots.
- Do not lay tools or metal parts on top of batteries.
- Disconnect charging source prior to connecting or disconnecting battery terminals.
- Determine if the battery is inadvertently grounded. If it is inadvertently grounded, remove the source of the ground. Contact with any part of a grounded battery can result in electrical shock. The likelihood of such shock will be reduced if grounds are removed during installation and maintenance (applicable to a UPS and a remote battery supply not having a grounded supply circuit).

1.7.4 Information for the Protection of the Environment

UPS SERVICING - This UPS makes use of components dangerous for the environment (electronic cards, electronic components). The components removed must be taken to specialized collection and disposal centers.

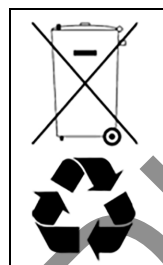

NOTICE TO ALL CUSTOMERS: DISPOSAL OF OLD APPLIANCES - This product has been supplied from an environmentally aware manufacturer that complies with the Waste Electrical and Electronic Equipment (WEEE) Directive 2002/96/CE. The “crossed-out wheeled bin” & recycle symbol is placed on this product to encourage you to recycle wherever possible. Please be environmentally responsible and recycle this product through your recycling facility at its end of life. Do not dispose of this product as unsorted municipal waste. Follow local municipal waste ordinances for proper disposal provisions to reduce the environmental impact of waste electrical and electronic equipment (WEEE).

1.7.5 Battery Replacement Procedure

1. Turn the UPS on its side.
2. Remove and set aside the two battery-compartment retaining screw (item 1).
3. Slide the battery compartment cover outward and lift-off to expose the battery (item 2).
4. Grasp the battery and gently pull it out far enough to disconnect the battery wires.
5. Disconnect the battery positive (Red) wire and the battery negative (Black) wire. (item 3).
6. Remove the battery and set aside.
7. Orient the new battery in the same direction as the original battery and place the new battery close enough to connect the battery wires.

NOTE: Replace the battery with the same type and number as originally installed.

8. Connect the battery negative (Black) wire to the battery negative terminal.
9. Connect the battery positive (Red) wire to the battery positive terminal.

NOTE: when connecting the last wire to the battery there can be a small spark, this is normal.

10. Fully insert the new battery into the UPS and re-install the battery compartment cover.
11. Re-install the battery compartment retaining screw.
12. Properly dispose of the old batteries at an appropriate recycling facility or return them to Vertiv™ in the packing material for the new batteries.
13. The UPS is now ready for normal operation.

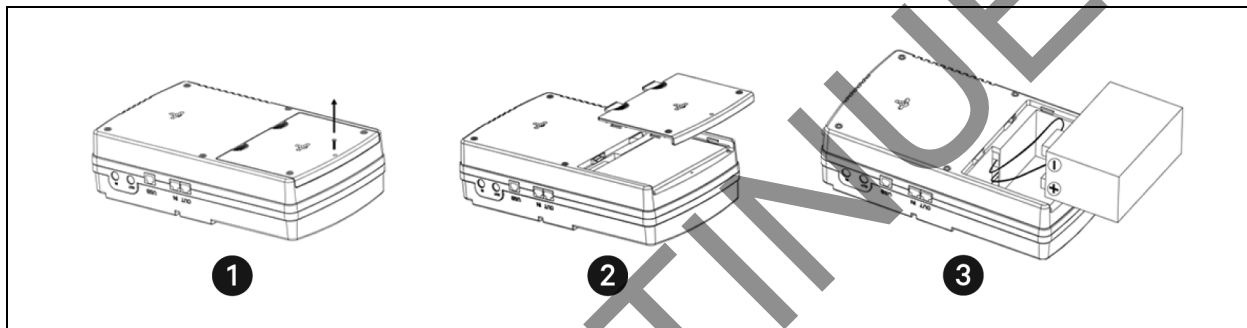

1.7.6 Specifications

Table 1.1 System Specifications

MODEL NUMBER	PST4-660MT120	PST4-850MT120
Capacity (VA / W)	660 / 400	850 / 500
Unit Dimensions, in. (mm) W x D x H	12.4 x 7.2 x 3.3 (314 x 183 x 83)	
Unit Weight, lbs (kg)	9.4 (4.3)	9.7 (4.4)
Shipping Dimensions, in. (mm) W x D x H	14.7 x 10.3 x 6.1 (373 x 261 x 155 mm)	
Shipping Weight, lbs (kg)	10.6 (4.8)	11.0 (5.0)
Input AC		
Nominal Voltage	120 VAC	
Voltage Range	100-140 VAC	
Frequency Range	50 or 60 Hz, ± 5 Hz, auto-sensing	
Protection	Resettable Circuit Breaker	
Surge Energy Rating	320 Joules	
Input Cord	6 ft. attached with NEMA 5-15P	
Output AC (On Utility)		
Nominal Voltage	120 VAC	
Voltage Range	96-146 VAC	
Frequency Range	50 or 60 Hz, ± 5 Hz, auto-sensing	
Efficiency	>90% at full load	
Output AC (On Battery)		
Nominal Voltage	120 VAC	
Voltage Range	Nominal $\pm 8\%$	
Frequency Range	50 or 60 Hz, $\pm 1\%$	
Waveform	PWM Simulated Sine wave	
Transfer Time	6-8 ms, typical	
Overload Capacity	110% for 10 seconds, 120% immediate shutdown	
Protection	Electronic (over current, short circuit w/ latching shutdown)	
Backup Time (Full Load / Half Load), min	2 / 9	2 / 7
Battery Type	Valve Regulated Lead Acid (VRLA)	
Battery Manufacturer / Model	CSB / GP1272 Leoch / DJW12-7.0	CSB / HR Leoch / DJW12-9.0
Battery Quantity x VDC x Ah	1 x 12V x 7.0 / 7.2Ah	1 x 12V x 9.0Ah
Battery Backed Outlets	(4) NEMA 5-15R	
Surge Only Outlets	(4) NEMA 5-15R	

Table 1.1 System Specifications

MODEL NUMBER	PST4-660MT120	PST4-850MT120
Environmental Requirements		
Operating Temperature, deg(degC)	32-104 (0-40) without derating	
Operating Elevation, feet (meter)	0-4,921 (0-1,500) without derating	
Operating Temperature, degF (degC)	32-86 (0-30) without derating	
Operating Elevation, feet (meter)	4,922-9,842 (1,500.5-3,000) without derating	
Relative Humidity	0-95% non-condensing	
Storage Temperature, degF (degC)	5 to 113 (-15 to 45)	
Storage Elevation, feet (meter)	0-49,212 (0-15,000)	
Audible Noise	<40 dBA @ 3 ft (1 m) from all sides	
Agency		
Safety	cTUVus (UL 1778 / CSA22.2 No. 107.1)	
RFI / EMI	FCC Subpart J, Class B	
Surge Immunity	ANSI 62.41 (IEC 62040-2 2nd Edition)	
Transportation	ISTA Procedure 1A	

DISCONTINUED

DISCONTINUED

This page intentionally left blank.

APPENDICES

Appendix 1: Technical Support

Our Technical Support staff is ready to assist you with any installation or operating issues you may encounter with your Liebert product. Please call or e-mail us:

Technical support:

e: liebert.upstech@vertivco.com

p: 1-800-222-5877 menu option 1

Monitoring support:

e: liebert.monitoring@vertivco.com

p: 1-800-222-5877 menu option 2

Warranty support:

e: microups.warranty@vertivco.com

p: 1-800-222-5877 menu option 3

DISCONTINUED

DISCONTINUED

This page intentionally left blank.

DISCONTINUED

DISCONTINUED



VertivCo.com | Vertiv Headquarters, 1050 Dearborn Drive, Columbus, OH, 43085, USA

© 2017 Vertiv Co. All rights reserved. Vertiv and the Vertiv logo are trademarks or registered trademarks of Vertiv Co. All other names and logos referred to are trade names, trademarks or registered trademarks of their respective owners. While every precaution has been taken to ensure accuracy and completeness herein, Vertiv Co. assumes no responsibility, and disclaims all liability, for damages resulting from use of this information or for any errors or omissions. Specifications are subject to change without notice.

SL-23289_REV2_3-17/590-1412-501C