



NetSure™ IPE Series Rectifier

Installation and User Manual

Specification Number: 02131111

Model Number: R48-2000C

The information contained in this document is subject to change without notice and may not be suitable for all applications. While every precaution has been taken to ensure the accuracy and completeness of this document, Vertiv assumes no responsibility and disclaims all liability for damages resulting from use of this information or for any errors or omissions. Refer to other local practices or building codes as applicable for the correct methods, tools, and materials to be used in performing procedures not specifically described in this document.

The products covered by this instruction manual are manufactured and/or sold by Vertiv. This document is the property of Vertiv and contains confidential and proprietary information owned by Vertiv. Any copying, use or disclosure of it without the written permission of Vertiv is strictly prohibited.

Names of companies and products are trademarks or registered trademarks of the respective companies. Any questions regarding usage of trademark names should be directed to the original manufacturer.

Technical Support Site

If you encounter any installation or operational issues with your product, check the pertinent section of this manual to see if the issue can be resolved by following outlined procedures.

Visit <https://www.vertiv.com/en-us/support/> for additional assistance.

TABLE OF CONTENTS

Admonishments Used in this Document.....	v
Important Safety Instructions.....	vi
1 Introduction.....	1
1.1 General.....	1
1.2 What is in the Box.....	1
1.3 Rectifier Overview.....	1
1.4 Rectifier Specifications.....	1
1.4.1 DC Output Ratings.....	1
1.4.2 AC Input Ratings.....	3
1.4.3 Environmental Ratings.....	6
1.4.4 Compliance Information.....	7
1.4.5 Standard Features.....	7
1.4.6 Mechanical Specifications.....	9
2 Installing the Rectifier.....	10
2.1 General.....	10
2.2 Pole Installation Procedure.....	10
2.3 Wall Installation Procedure.....	13
3 Making Electrical Connections.....	15
3.1 Important Safety Instructions.....	15
3.2 Wiring Considerations.....	15
3.3 Frame Ground Connection.....	15
3.4 Customer Wiring to Terminal Blocks Located Inside Rectifier Case.....	16
3.4.1 General.....	16
3.4.2 Procedure.....	16
3.5 External Alarm and Control Connections.....	21
3.5.1 General.....	21
3.5.2 Contact Ratings (UL / CSA Rating):.....	21
3.5.3 Rectifier Fail Alarm.....	22
3.5.4 AC Fail Alarm.....	22
3.5.5 Fuse Alarm.....	22
3.5.6 CAN.....	22
3.6 Nominal 120 VAC / 208 VAC / 220 VAC / 230 VAC / 240 VAC Input and AC Input Equipment Grounding Connections.....	22
3.7 -48 VDC Output Connections.....	22
3.8 Battery Connections.....	23
3.9 Paralleling Rectifiers for Redundancy.....	23
4 Initially Starting the Rectifier.....	24
5 Operation.....	24
5.1 Rectifier High Voltage Shutdown and Lockout Restart.....	24
6 Troubleshooting and Repair.....	24
6.1 Contact Information.....	24
6.2 Troubleshooting.....	24

6.2.1 Rectifier Current Sharing Imbalance	24
6.3 Repair	24

Admonishments Used in this Document



DANGER! Warns of a hazard the reader *will* be exposed to that will *likely* result in death or serious injury if not avoided. (ANSI, OSHA)



WARNING! Warns of a potential hazard the reader *may* be exposed to that *could* result in death or serious injury if not avoided. This admonition is not used for situations that pose a risk only to equipment, software, data, or service. (ANSI)



CAUTION! Warns of a potential hazard the reader *may* be exposed to that *could* result in minor or moderate injury if not avoided. (ANSI, OSHA) This admonition is not used for situations that pose a risk only to equipment, data, or service, even if such use appears to be permitted in some of the applicable standards. (OSHA)



ALERT! Alerts the reader to an action that *must be avoided* in order to protect equipment, software, data, or service. (ISO)



ALERT! Alerts the reader to an action that *must be performed* in order to prevent equipment damage, software corruption, data loss, or service interruption. (ISO)



FIRE SAFETY! Informs the reader of fire safety information, reminders, precautions, or policies, or of the locations of fire-fighting and fire-safety equipment. (ISO)



SAFETY! Informs the reader of general safety information, reminders, precautions, or policies not related to a particular source of hazard or to fire safety. (ISO, ANSI, OSHA)

Important Safety Instructions

Safety Admonishments Definitions

Definitions of the safety admonishments used in this document are listed under “Admonishments Used in this Document” on page v.

Safety and Regulatory Statements

Refer to Section 4154 (provided with your customer documentation) for Safety and Regulatory Statements.

Déclarations de Sécurité et de Réglementation

Reportez-vous à la Section 4154 (fourni avec les documents de votre client) pour les déclarations de sécurité et de réglementation.

1 Introduction

1.1 General

The Vertiv™ NetSure™ IPE Series provides a rectifier mounted inside an environmentally protective enclosure. The Vertiv™ NetSure™ IPE Series rectifier can be wall or pole mounted.

1.2 What is in the Box

Refer to **Table 1**.

Table 1:

Part Number	Description	Qty.
02131111	NetSure IPE Series Rectifier	1
21505943	Pole/Wall Mount Kit	1
63126330	Pole Mount Band	2
6312017Y	Security Screw Wrench	1
UM02131111	Installation and User Manual	1

1.3 Rectifier Overview

The rectifier provides load power during normal operating conditions. The rectifier is a constant power design. The rectifier is rated at its maximum output power. This means that, within the normal operating ambient temperature range and input voltage range, the maximum available output power is a constant 2000 W. Within these ranges, the rectifier operates in one of three modes, depending upon load demands. Transition between modes is completely automatic. If ambient temperature rises above or input voltage falls below acceptable values, the rectifier continues to operate but at derated output power levels.

- **Constant Voltage Mode:** For any initial output voltage setting from -42 VDC to -58 VDC (factory set at -54 VDC), output voltage remains constant regardless of load. This is the normal operating condition, in which loads are being supplied. The rectifier operates in the Constant Voltage Mode unless load increases to the point where the product of load current and output voltage is approximately 2000 W.
- **Constant Power Mode:** As load increases above approximately 2000 W (non-adjustable), output current continues to increase, but output voltage decreases as required to maintain constant output power. The rectifier operates in the Constant Power Mode unless load continues to increase to the point where the current limit setting is reached.
- **Constant Current Mode:** If load increases to the current limit setting, output voltage decreases linearly to maintain output current at the current limit setting.

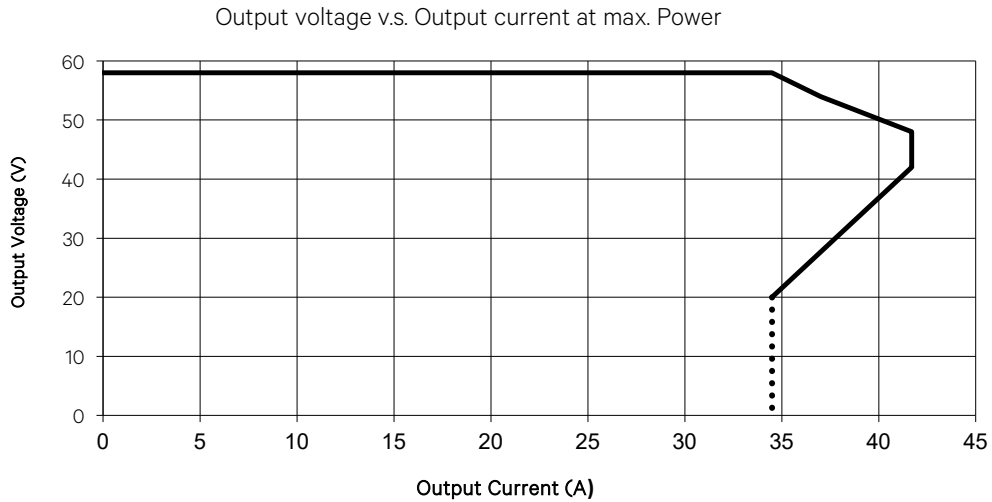
1.4 Rectifier Specifications

The specifications are for a single unit only, unless otherwise noted.

1.4.1 DC Output Ratings

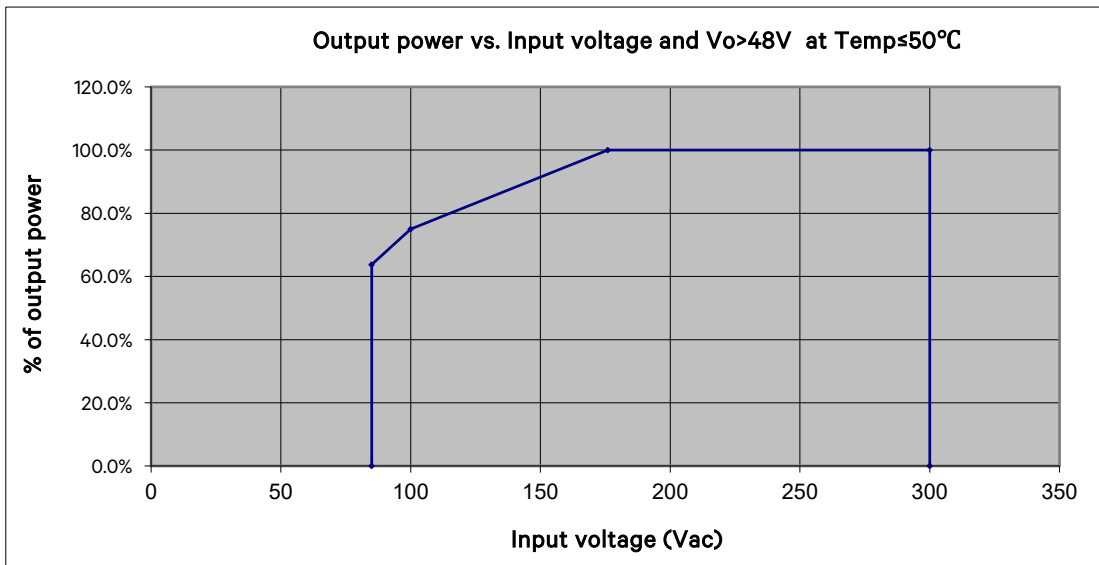
1. **Voltage:** -42 VDC to -58 VDC, positive ground. Output voltage is factory set at -54 VDC.
2. **Output Power and Current:** 2000 W (41.7 A) @ 200 VAC to 250 VAC input and -48 VDC output.
3. **Output Characteristics:** Refer to **Figure 1** for a graph of output voltage vs. output current.

Figure 1: Output Voltage vs. Output Current



4. Power Derating Based on Input Voltage: The rectifier power varies with changes in input voltage. It uses an advanced power limitation method. The lower input threshold is 85 VAC. The rectifier can provide its maximum rated power (2000 W) as long as the input voltage is within the range of 176 VAC to 300 VAC. Below 176 VAC, and down to 85 VAC, the rectifier will continue to operate normally but will be in a power derating mode. The relationship between the output power and input voltage is illustrated in **Figure 2**.

Figure 2: Power Derating Based on Input Voltage



5. Power Derating Based on Temperature: The rectifier delivers full power when operating at an ambient temperature of +50 °C (+122 °F) or below. The rectifier continuously monitors the ambient temperature surrounding the power conversion circuit. If this temperature for any reason (such as a high ambient temperature) increases above approximately +50 °C (+122 °F), the rectifier will not shut down. Rather, the rectifier limits its maximum output power to maintain the temperature of the power conversion circuit within design parameters. Operation between +50 °C (+122 °C) and +75 °C (+167 °F) will result in output power being decreased. Full power capability is restored when the temperature decreases to below approximately +50 °C (+122 °F). Refer to **Figure 3** to view the relationship between the output power and the ambient temperature.



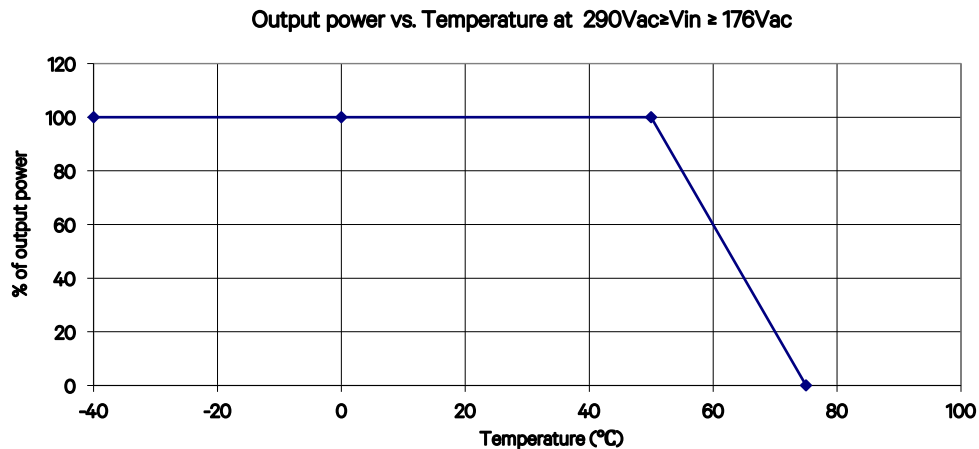
WARNING! The module is rated for continuous operation at full output power up to +50 °C (+122 °F). Operation between +50 °C (+122 °F) and +75 °C (+167 °F) will result in output power decrease. Operation above +75 °C (+167 °F) is considered abnormal and should be used on a temporary¹ basis only.

- ¹ Temporary Operation at Abnormal Temperature: Temporary operation is defined as a period of not more than eight consecutive hours per day, and a total of not more than 15 days in a year. (This refers to a total of 120 hours in any given year, but no more than 15 occurrences in that one-year period.)

Other power rating values are as follows (refer to **Figure 3**):

- At an ambient temperature of +65 °C (+149 °F), the power delivered by the rectifier is 800 W.
- At an ambient temperature of +75 °C (+167 °F), the power delivered by the rectifier is 0 W.

Figure 3: Power Derating Based on Temperature



6. Regulation:

- Static: Steady state regulation is $\pm 0.6\%$ as controlled within the rectifier for any and all combinations of load from 5% to 100% load, input voltage, and input frequency at a constant ambient temperature.
- Dynamic: Response time ≤ 200 μ s and overshoot $\leq 5\%$ for load changes at 50% - 25% - 50% and 50% - 75% - 50% at rated output current.

For any step load change within the range of 10% to 90% of full load within 50 microseconds, per Telcordia GR-947-CORE, the maximum voltage transient will not exceed 5% of the initial steady state voltage within 50 ± 10 microseconds. Recovery to within 1% of the initial steady state voltage does not exceed 4 milliseconds.

7. Filtering:

- Voice Band Noise: Peak-peak voltage is ≤ 200 mV at 0 MHz to 20 MHz and normal output voltage.
- Wide Band Noise: Wideband noise voltage is ≤ 50 mV at 3.4 kHz to 150 kHz and ≤ 20 mV at 0.15 MHz to 30 MHz.

1.4.2 AC Input Ratings

- Voltage: Nominal 120 VAC / 208 VAC / 220 VAC / 230 VAC / 240 VAC, single phase, 3-wire, 50 Hz / 60 Hz, with an operating range of 85 VAC to 300 VAC. Acceptable input frequency range is 45 Hz to 65 Hz.

Permitted Variation: 85 VAC to 300 VAC.

2. Harmonic Content (THD): Meets EN61000-3-2. $\leq 5\%$ from 50% to 100% of rated output current at 230 VAC.
3. Inrush Current: Peak does not exceed 1.5 times of the peak value of the maximum steady-state input current at full load, 230 VAC input voltage, and for any duration of AC input interrupts. Under the above conditions, standard AC distribution circuit breakers will not trip.
4. Typical Input Data: 50 Hz input.
 - a) Refer to **Table 2**.
 - b) Maximum Input Current: Refer to **Table 3**.
 - c) Efficiency Curve: Refer to **Figure 4**.
5. Typical Input Data: 60 Hz input.
 - a) Refer to **Table 4**.
 - b) Maximum Input Current: Refer to **Table 5**.
 - c) Efficiency Curve: Refer to **Figure 5** and **Figure 6**.

Table 2: Typical Input Data with 50 Hz Input

Nominal Input Voltage	Percent of Full Load	Input Current (Amperes)	Input VA	Input Watts	Power Factor	Efficiency %	Heat Dissipation BTU/Hr
208	0	0.747	156.234	13.4	0.080	--	45.654
	25	2.559	534.2	514.9	0.960	90.901	159.854
	50	4.850	1012.9	992.3	0.979	93.979	203.849
	75	7.130	1485.3	1475.8	0.993	94.642	269.828
	100	9.503	1973.8	1962.1	0.994	94.736	352.417
	110	10.457	2170.5	2159.9	0.995	94.543	402.201
240	0	0.861	207.6	12.9	0.060	--	44.017
	25	2.311	557.9	513.8	0.923	91.524	148.579
	50	4.206	1012	989.1	0.977	94.318	191.752
	75	6.180	1485.7	1471.1	0.990	94.944	253.791
	100	8.195	1967.1	1955.3	0.994	94.907	339.803
	110	9.010	2162	2152.0	0.995	94.872	376.540

Note: System output is initially adjusted to 54 volts DC as measured at the system sense point at 50% of full load and nominal input. "Percent of Full Load" refers to percent of 34.48 amperes.

Table 3: Maximum Input Current with 50 Hz Input

Nominal Input Voltage	Input Voltage	Input Current (Amperes)
208/240	176	11.98

Note: At 100% of full load with output adjusted to 58 volts DC as measured at the output terminals.

Table 4: Typical Input Data with 60 Hz Input

Nominal Input Voltage	Percent of Full Load	Input Current (Amperes)	Input VA	Input Watts	Power Factor	Efficiency %	Heat Dissipation BTU/Hr
120	0	0.533	64.1	18.7	0.283	0	63.602
	25	4.403	528.6	524.8	0.994	90.028	178.566
	50	8.438	1006.9	1005.8	0.999	92.735	249.324
	75	12.66	1503	1501.9	0.999	92.945	361.533
	100	--	--	--	--	--	--
	110	--	--	--	--	--	--
208	0	0.896	187.4	13.4	0.070	0.000	45.586
	25	2.615	545.9	517	0.947	90.968	159.338
	50	4.840	1010.4	991.9	0.982	94.052	201.306
	75	7.150	1487.7	1475.7	0.992	94.648	269.487
	100	9.506	1974.8	1961.7	0.994	94.720	353.405
	110	10.460	2171.1	2159.6	0.995	94.679	392.108
240	0	1.031	248.9	13.0	0.050	0.000	44.494
	25	2.376	575.8	517.3	0.907	91.333	152.975
	50	4.241	1020.7	989.2	0.969	94.309	192.093
	75	6.198	1489.7	1471.3	0.987	94.931	254.473
	100	8.203	1969.9	1955.1	0.993	95.040	330.885
	110	9.018	2163.5	2152.1	0.995	95.009	366.517

Note: System output is initially adjusted to 54 volts DC as measured at the system sense point at 50% of full load and nominal input. "Percent of Full Load" refers to percent of 34.48 amperes.

Table 5: Maximum Input Current with 60 Hz Input

Nominal Input Voltage	Input Voltage	Input Current (Amperes)
208/240	176	11.98

Note: At 100% of full load with output adjusted to 58 volts DC as measured at the output terminals.

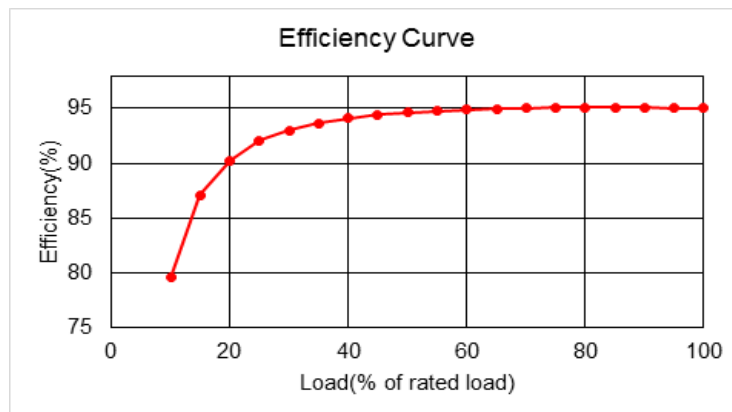
Figure 4: Efficiency Curve (@ 230 VAC, 50 Hz)

Figure 5: Efficiency Curve (@ 240 VAC, 60 Hz)

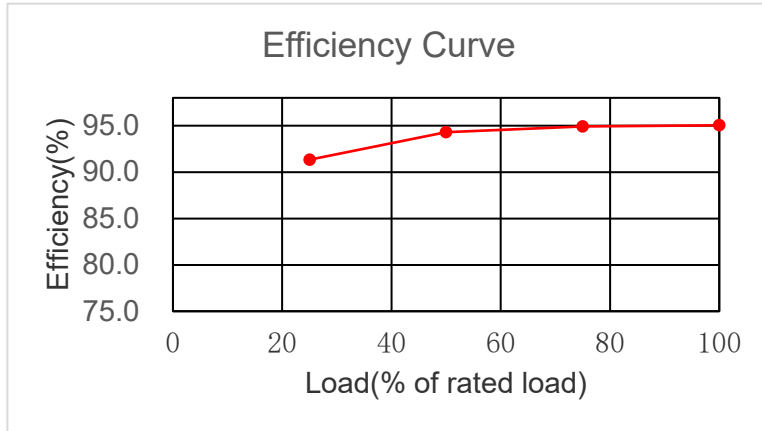
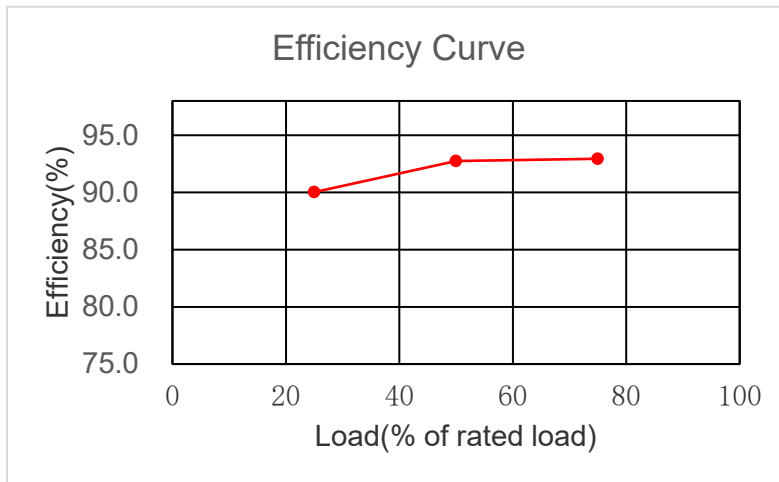


Figure 6: Efficiency Curve (@ 120 VAC, 60 Hz)



1.4.3 Environmental Ratings

1. Operating Ambient Temperature Range:
 - a) -20 °C (-4 °F) to +50 °C (+122 °F) with full power performance.
 - b) +50 °C (+122 °F) to +75 °C (+167 °F) with derating output.
 - c) Temperature Coefficient: 0.02% per degrees Celsius.
2. Storage Ambient Temperature Range: -40 °C (-40 °F) to +70 °C (+158 °F).
3. Relative Humidity: This rectifier is capable of operating in an ambient relative humidity range of 0% to 95%.
4. Altitude: 3048 m (9842 feet).

5. Surge Protection: EN61000-4-5 up to level 4, Telcordia GR-1089-Core, IEEE C62.41-2002, YD/T 731-2002.

Performance Criteria B.

AC Power Terminals

Test Level		Source Impedance	Performance Criteria
Line to Line	Line to Ground		
± 4 kV	± 4 kV	2 ohms	B
NA	± 6 kV	12 ohms	B

DC Power Terminals:

Test Level		Source Impedance	Performance Criteria
Line to Line	Line to Ground		
± 500 V	± 500 V	2 ohms	B
± 800 V	± 800 V	2 ohms	B

The test method is described in EN 61000-4-5. In this test the DC-cables shall be 5 m long.

6. Single Rectifier Audible Noise: At 25 °C ≤45 dB(A). Measurement made at 0.6 m distance in front of rectifier and at same horizontal line of the middle of rectifier.
7. High Voltage Category (per UL60950): III
8. Power Distribution System: TN/TT/IT
9. EMI/RFI Suppression:
- The rectifier conforms to the requirements of FCC rules Part 15, Class B for radiated and conducted emissions limits.
 - The rectifier conforms to the requirements of European Norm, EN55022, Class B for radiated and conducted emissions limits.
10. Pollution Degree: Degree 3.

1.4.4 Compliance Information

- EMC: ETSI EN 300 386, FCC CFR 47 Part 15 class B, Telcordia GR-1089-CORE.
- EMI Load Range: 10% to 100%.
- Safety: UL 60950-1, UL 60950-22, EN 60950-1, IEC 60950-1.
- NEBS.

1.4.5 Standard Features

- Type of Power Conversion Circuit: High frequency.
- Input Protection:
 - Input Over/Under Voltage Protection: The rectifier will shut down at low or high voltage input; based on the following voltage levels:

Low Voltage Disable Point: 80 VAC, ±5 V; hysteresis is at least 15 VAC for restart.

High Voltage Disable Point: 305 VAC, ± 5 V; hysteresis is at least 10 VAC for restart.

- b) Between 85 VAC and 176 VAC the output power will be derated linearly based on the input voltage as follows:

At input voltage of 85 VAC with output >48 VDC, maximum output power is 1275 W.

At input voltage of 176 VAC with output >48 VDC, maximum output power is 2000 W.

3. Output Protection:

- a) Overload / Reverse Current: The rectifier has a fuse wire in the negative output DC bus. This fuse is not customer replaceable.
- b) Current Limiting: The rectifier has a current limit function. The current limit point is factory set at 41.7 A. The current limit accuracy is ± 1.5 A when the output voltage ranges from 42 VDC to 58 VDC.
- c) Advanced Current Limit Function: The rectifier has an advanced Current Limit Function. When a short circuit occurs at the rectifier output terminals, the rectifier will keep its output current at a constant value (factory set at 34.5 A). This function effectively protects the rectifier and the equipment connected to the rectifier. When the short circuit fault is cleared, the rectifier will automatically restore back to normal operation.
- d) High Voltage Shutdown:

- Fixed Control: If rectifier output voltage exceeds a factory set value of 59.5 VDC and the rectifier is delivering more than 10% of its rated current, the rectifier shuts down. (The restart hysteresis is 0.5 V \pm 0.2 V.)

The rectifier then restarts and a HVSD restart timer starts (factory set at 5 minutes). If output voltage again exceeds the high voltage shutdown value before the HVSD restart timer expires, the rectifier shuts down and locks out. Manual restart is then required (by turning power to the rectifier off, waiting 30 seconds or more, then turning power to the rectifier on). If the rectifier does not experience a high voltage condition before the HVSD restart timer expires, the restart circuit is reset.

If two or more rectifiers are paralleled, only the rectifier causing the high voltage condition shuts down.

- Backup: If rectifier output voltage exceeds 59.5 VDC \pm 0.5 V (non-adjustable), the rectifier shuts down. The rectifier then restarts and a HVSD restart timer starts (factory set at 5 minutes). If output voltage again exceeds the high voltage shutdown value before the HVSD restart timer expires, the rectifier shuts down and locks out. Manual restart is then required (by turning power to the rectifier off, waiting 30 seconds or more, then turning power to the rectifier on).

4. Over-Temperature Protection: The rectifier provides over temperature protection by derating output power and recovers automatically.
5. Active Load Sharing: The rectifier uses advanced digital active load sharing technology that maintains balancing to within 5% of rated current.
6. Paralleling: Up to three (3) rectifiers can be connected in parallel in one system. Do not exceed the load rating of a single rectifier.
7. Monitoring Function: The rectifier has a built-in advanced DSP that monitors and controls the operation of the rectifier.



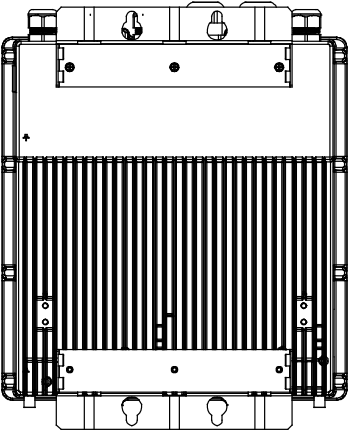
CAUTION! Double pole/neutral fusing.

1.4.6 Mechanical Specifications

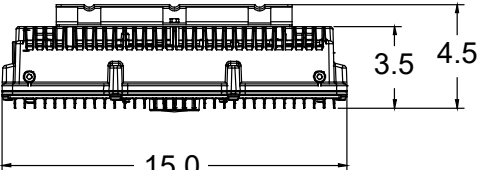
Dimensions and Weight

Refer to **Figure 7**.

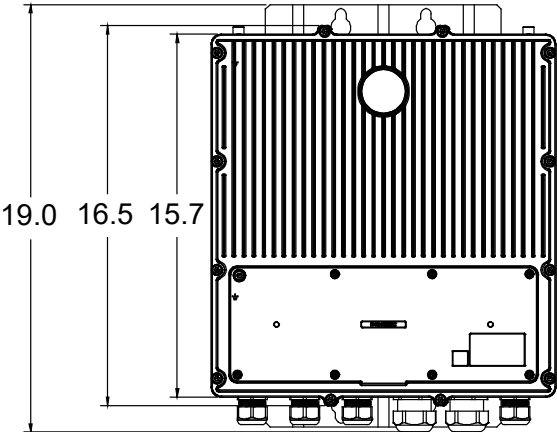
Figure 7: Overall Dimensions and Weight



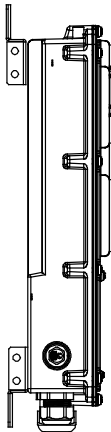
Rear View



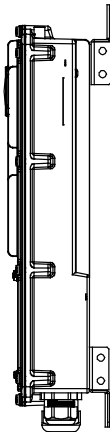
Top View



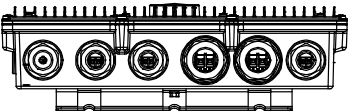
Front View



Left Side View



Right Side View



Bottom View

- Notes:
- 1. Dimensions are in inches.
 - 2. Finish: Aluminum with powder paint.
 - 3. Net Weight: 24.25 lbs.

2 Installing the Rectifier

2.1 General

The rectifier can be pole mounted or secured to a suitable wall.

For mounting; use a corrosion inhibiting compound (CIC) inside the tapped mounting holes to keep water away, or use organically plated stainless steel bolts. See **Figure 9** and **Figure 14**.

2.2 Pole Installation Procedure



NOTE! Torque all hardware to the values shown in the illustrations.

1. Unpack the rectifier and mounting accessories.
2. Install the mounting bracket (big) in the appropriate top position on the pole with the supplied pole mount band. Securely tighten the pole mount band to the pole. The pole mount band accommodates poles from 6" to 12" in diameter. Refer to **Figure 8**.
3. Install mounting brackets to the rear panel of the rectifier with the supplied hardware. Refer to **Figure 9**.
4. Secure the connect bend bracket to the rear of rectifier with the supplied M6 bolts (optional). Refer to **Figure 10**.
5. Secure the top of the rectifier to the pole by securing the mounting bracket (small) to the mounting bracket (big) with the supplied M8 bolts. Refer to **Figure 11**.
6. Secure the bottom of the rectifier to the pole by securing the mounting bracket (big) to the pole with the supplied pole mount band. Refer to **Figure 12**.

Figure 8: Installing the Mounting Bracket to the Pole with the Pole Mount Band

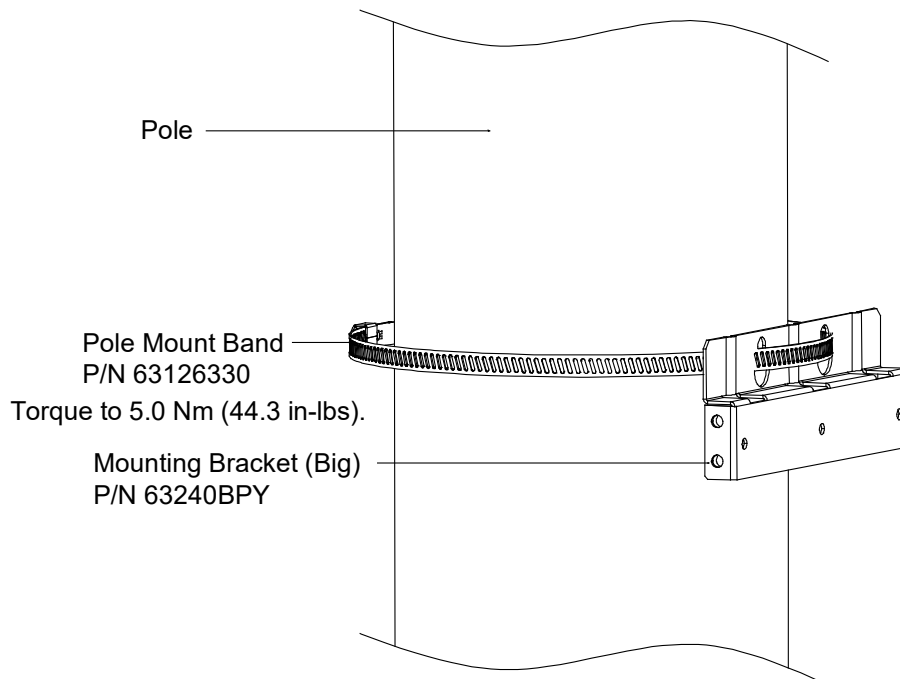


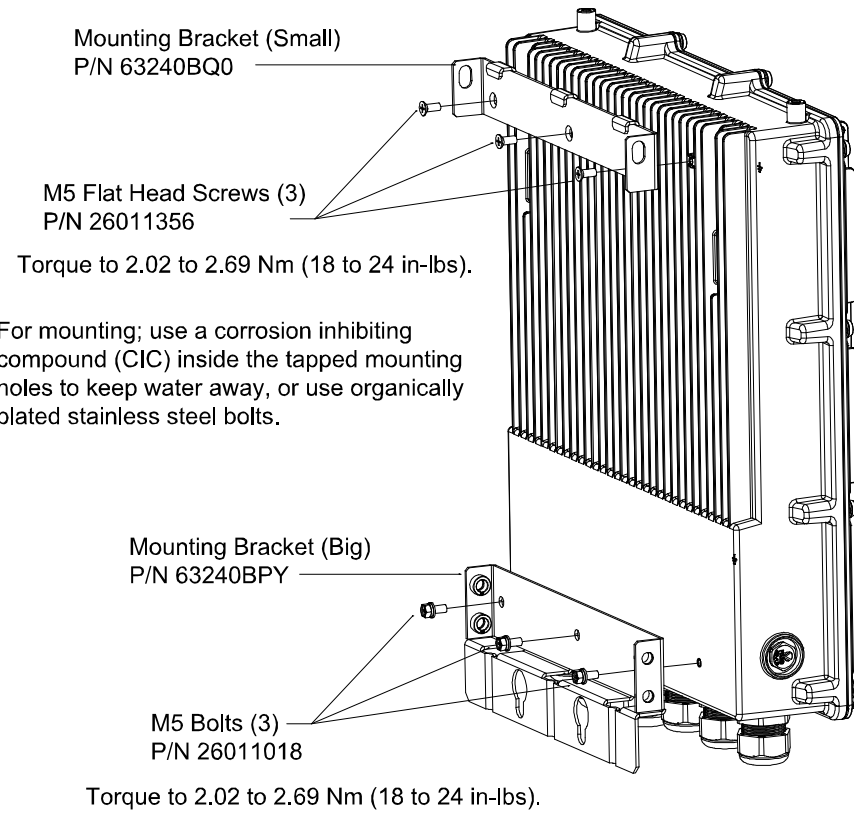
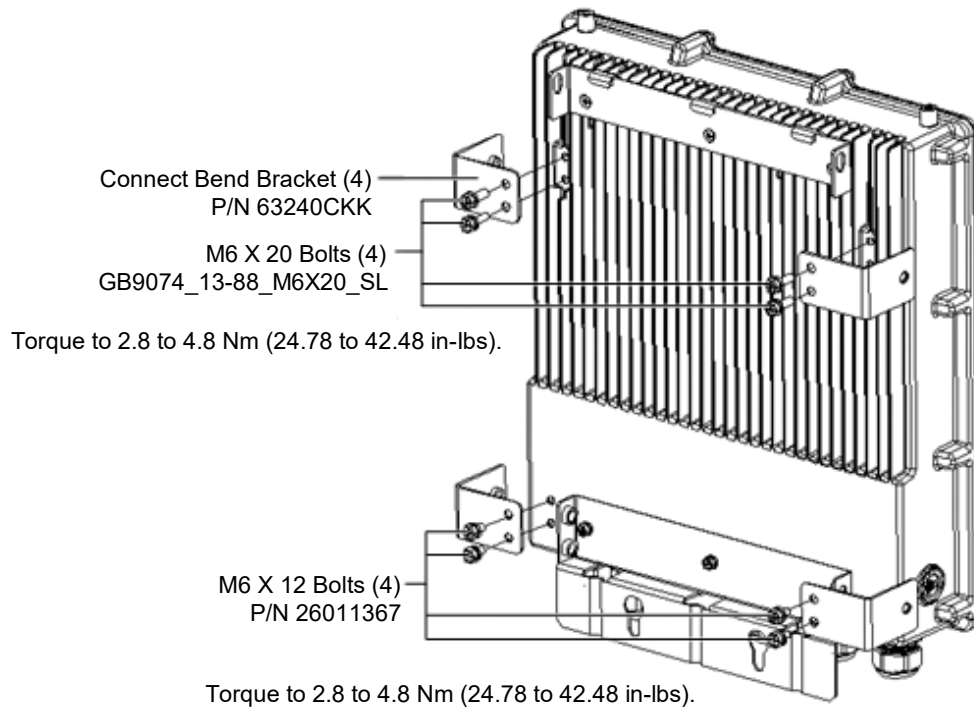
Figure 9: Installing the Mounting Brackets to the Rectifier**Figure 10: Installing the Connect Bend Bracket to the Rectifier (Optional)**

Figure 11: Securing the Rectifier to the Pole at the Top

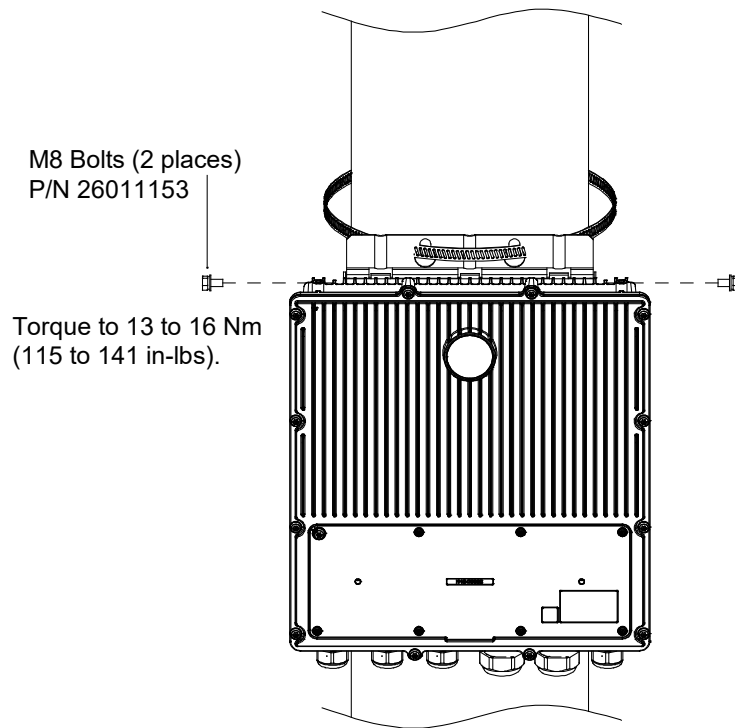
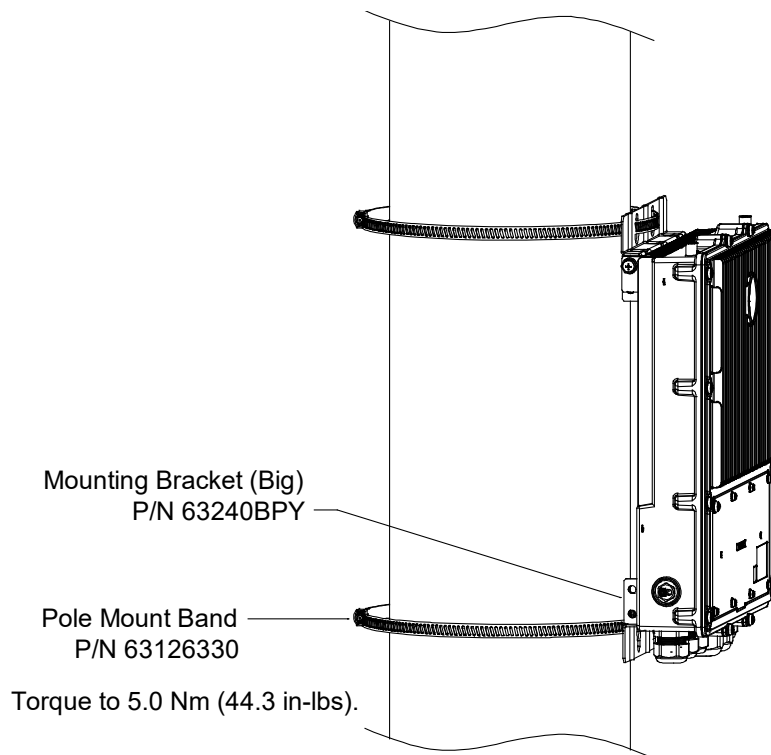


Figure 12: Securing the Rectifier to the Pole at the Bottom



2.3 Wall Installation Procedure



NOTE! Torque all hardware to the values shown in the illustrations.

1. Drill appropriately sized holes for the customer provided M8 wall anchors being used into the wall as shown in **Figure 13**. Note that the rectifier can be mounted horizontal or vertical. **Figure 13** shows horizontal mounting. Install the M8 wall anchors into the holes.
2. Install mounting brackets to the rear panel of the rectifier. Refer to **Figure 14**.
3. Secure the connect band bracket to the rectifier with the supplied M6 bolts (optional). Refer to **Figure 15**.
4. Secure the rectifier to the wall using the wall anchors previously installed. Refer to **Figure 16**.

Figure 13: Wall Mounting Hole Positions

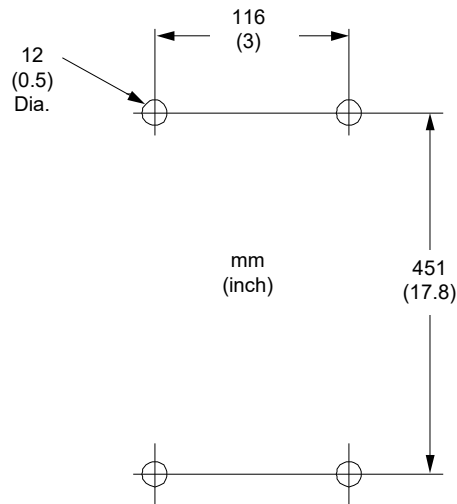


Figure 14: Installing the Mounting Brackets to the Rectifier

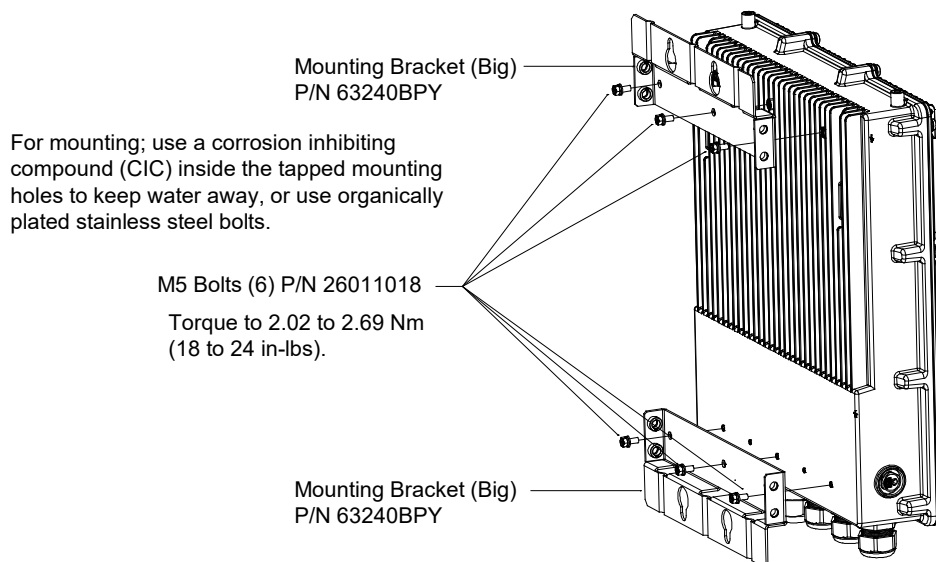


Figure 15: Installing the Connect Bend Brackets to the Rectifier (Optional)

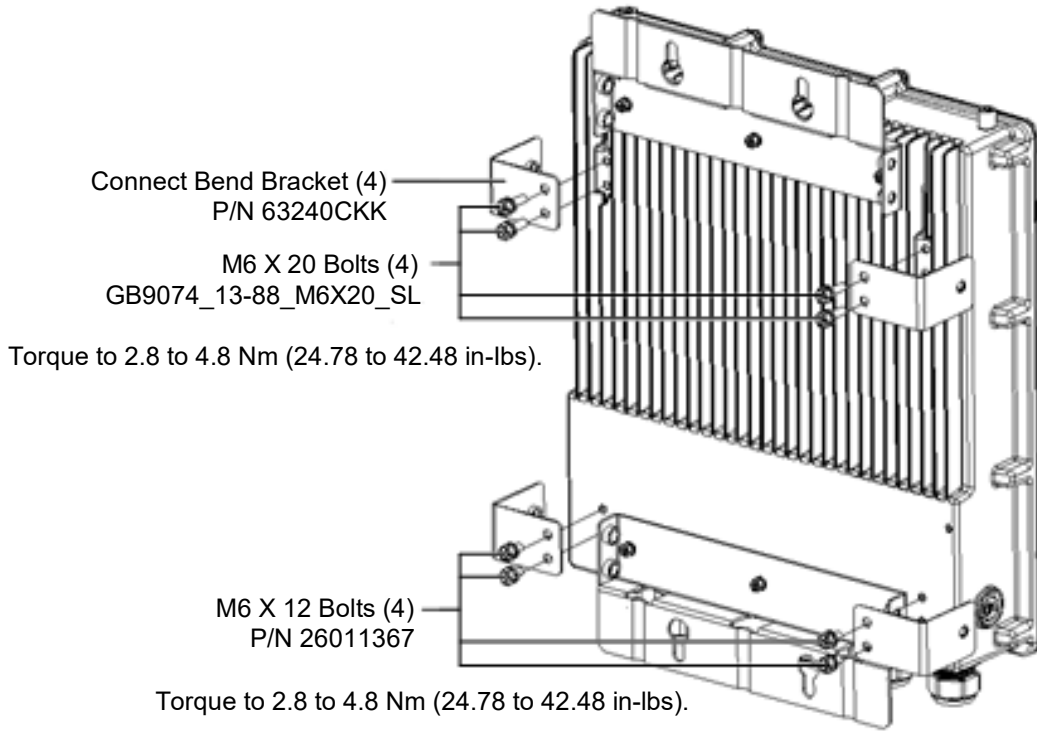
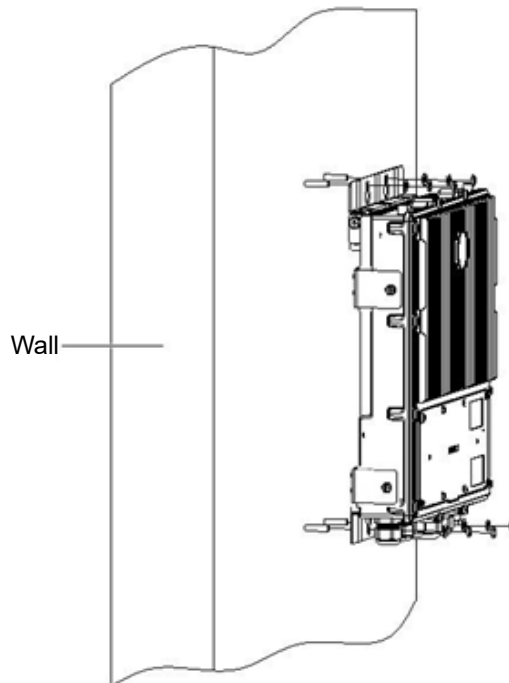


Figure 16: Securing the Rectifier to the Wall



3 Making Electrical Connections

3.1 Important Safety Instructions



DANGER! Adhere to the “Important Safety Instructions” starting on page vi.

3.2 Wiring Considerations

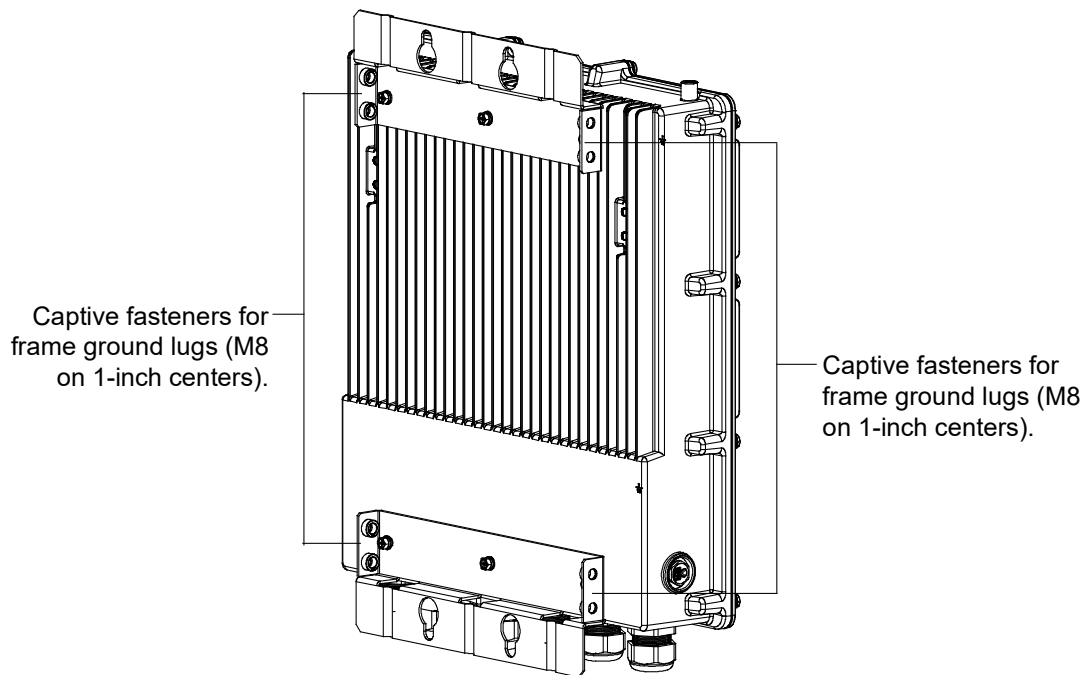
All wiring and branch circuit protection should follow the current edition of the American National Standards Institute (ANSI) approved National Fire Protection Association’s (NFPA) National Electrical Code (NEC), and applicable local codes. For operation in countries where the NEC is not recognized, follow applicable codes.

3.3 Frame Ground Connection

For grounding requirements, refer to the current edition of the American National Standards Institute (ANSI) approved National Fire Protection Association’s (NFPA) National Electrical Code (NEC), applicable local codes, and your specific site requirements.

Captive fasteners (for M8 bolts) for frame ground lugs are located on each mounting bracket. Holes are spaced on 1-inch centers. Refer to **Figure 17** for location.

Figure 17: Frame Grounding Location



3.4 Customer Wiring to Terminal Blocks Located Inside Rectifier Case

3.4.1 General

If any of the six (6) cable glands located on the bottom of the unit are left unused, screw the provided sealing pin onto the unused cable gland. See **Figure 21**.

3.4.2 Procedure

1. Strip cord insulation as required. Refer to **Figure 18**. Refer also to **Figure 25**.
2. Install the ferrule or ring lug as required. Refer to **Figure 18**. Refer also to **Figure 25**.

Figure 18: Strip Cord Insulation and Install Ferrule or Ring Lug (as required) (cont'd on next page)

UL2464 22 AWG (8 Conductor)
Maximum cable diameter is 6 mm (0.24 inch).
Strip 5 mm of insulation off the wires.

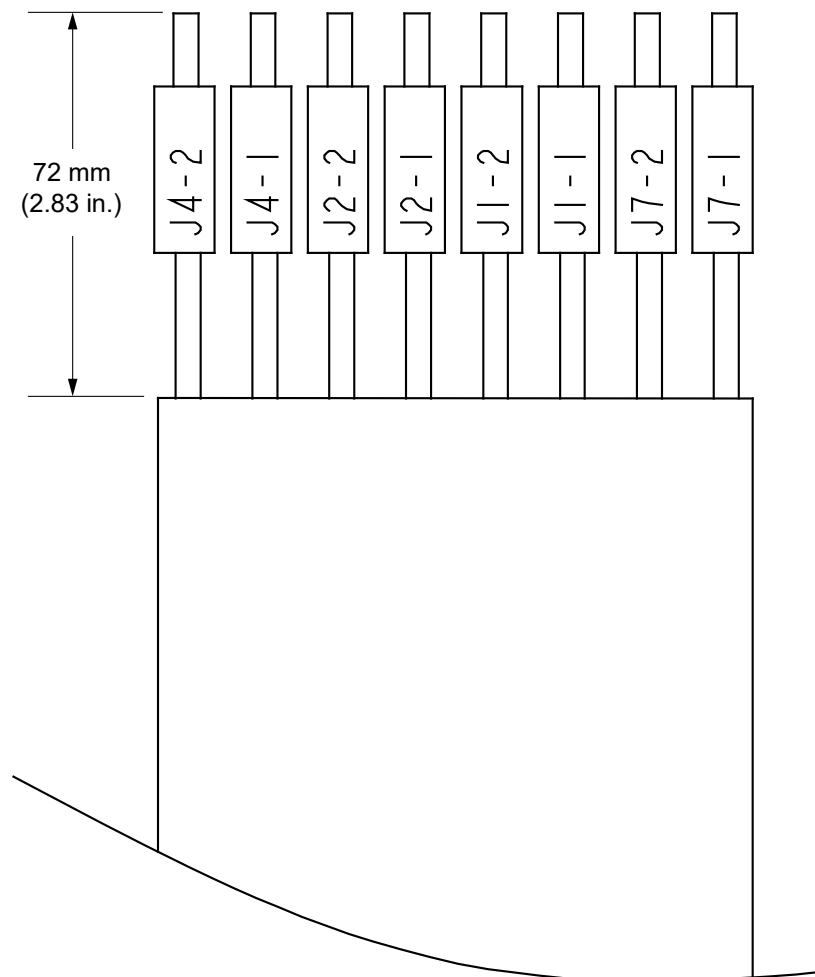
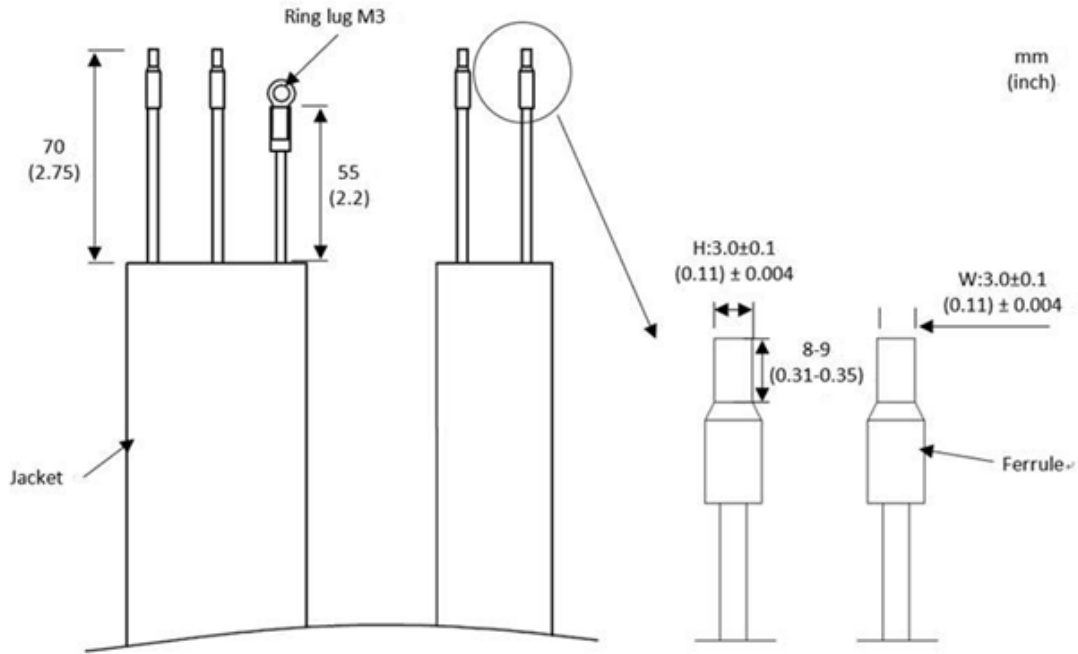
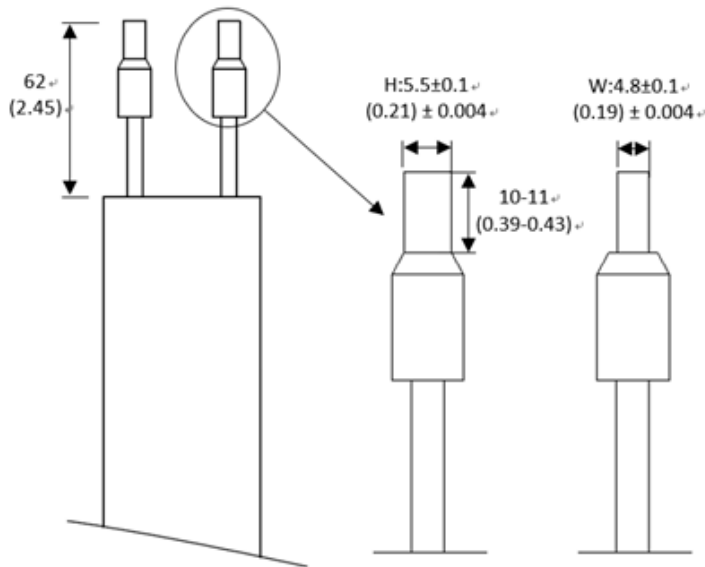


Figure 18: Strip Cord Insulation and Install Ferrule or Ring Lug (as required) (cont'd from previous page)



SJOOW 300V 12AWG 3/C
Sealing cable adapter
provided maximum cable
diameter is 9 mm to 16 mm
(0.35 inch to 0.63 inch).

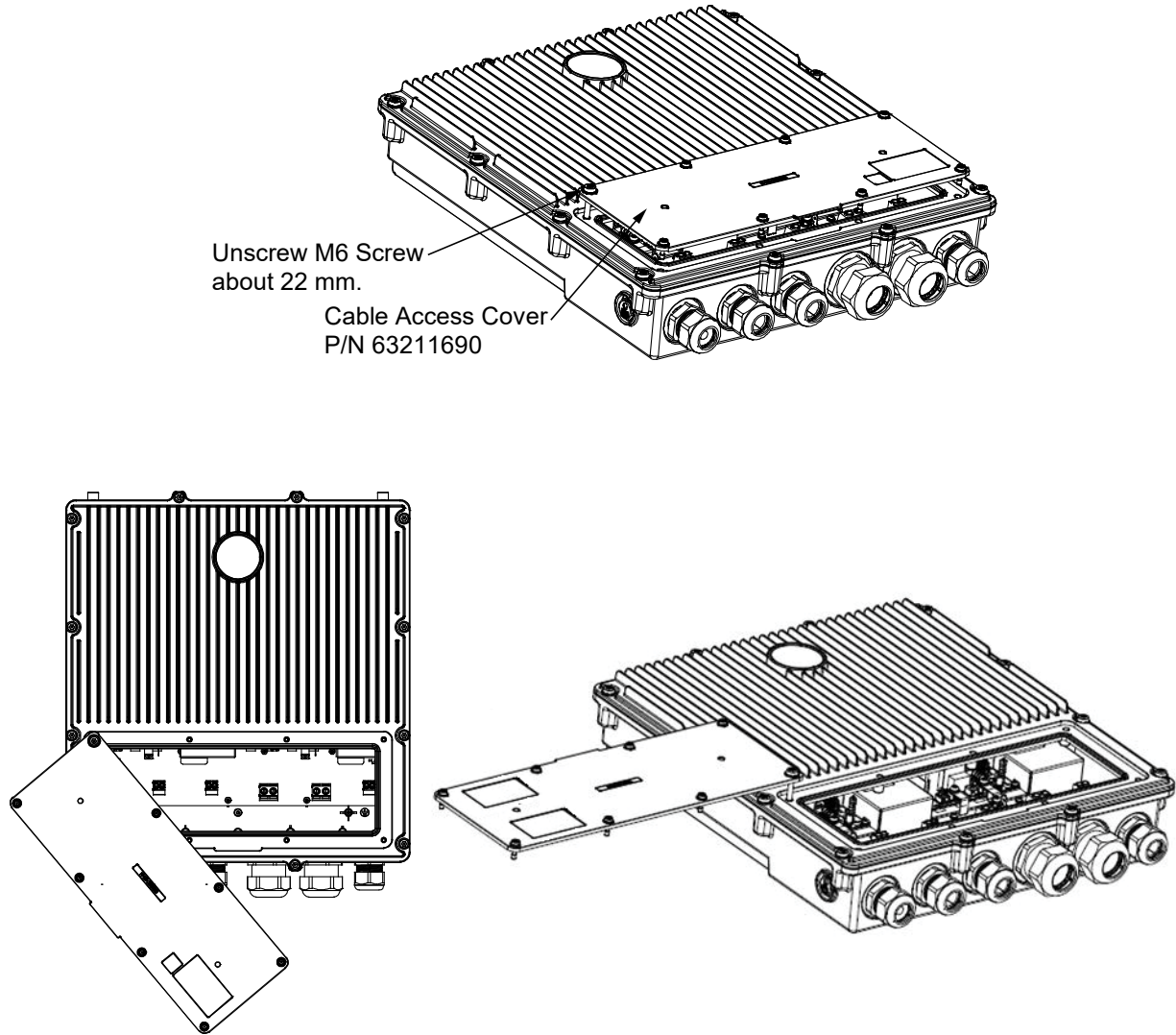
SJOOW 300V 10AWG 2/C
Sealing cable adapter
provided maximum cable
diameter is 9 mm to 16 mm
(0.35 inch to 0.63 inch).



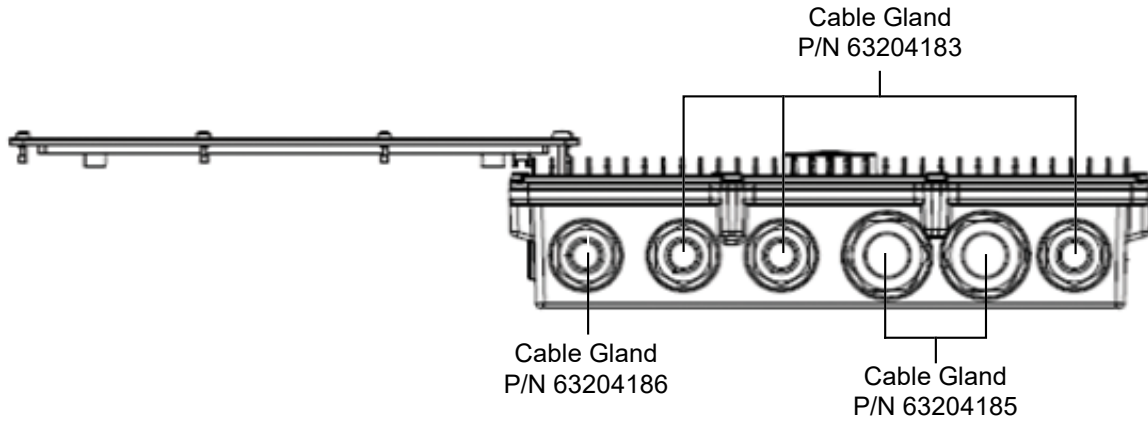
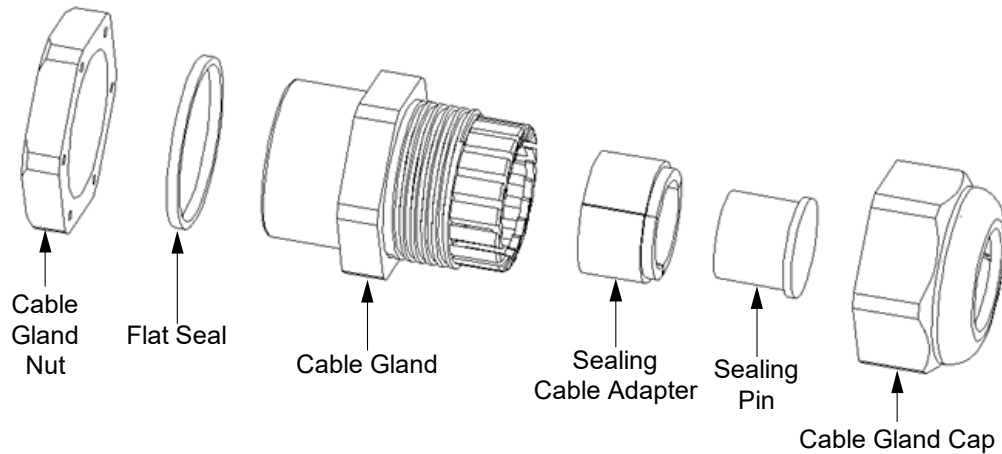
SJOOW 600V 6AWG 2/C
Sealing cable adapter
provide maximum cable
diameter is 18 mm to 25 mm
(0.71 inch to 1 inch).

3. Remove seven (7) M5 screws from cable access cover. Refer to **Figure 19**.
4. Unscrew the M6 screw in the upper left corner of the cable access cover about 22 mm and rotate the cover clockwise 180° around the M6 screw. Refer to **Figure 19**.

Figure 19: Unscrew the Cable Access Cover and Rotate the Cable Access Cover Clockwise 180° Around the M6 Screw



5. Unscrew the cable gland caps from the cable glands. Refer to **Figure 20** and **Figure 21**.
6. Remove the sealing pin in sealing cable adapter. See **Figure 21**.

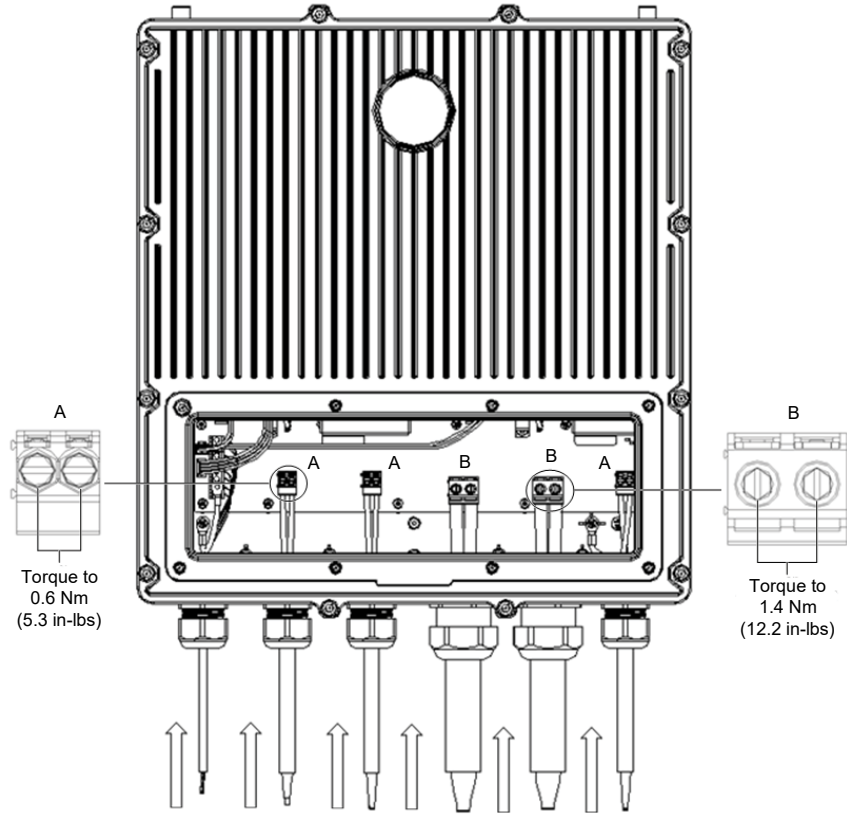
Figure 20: Unscrew the Cable Gland Caps**Figure 21: Cable Gland Diagram**

7. Slide the prepared cable(s) into the rectifier case through the appropriate cable gland. Connect the appropriate cables into the appropriate pins of the customer connection terminal blocks. Tighten the terminal block's screws to secure the wire. Torque as shown in **Figure 22**. See **Figure 25** for a "Customer Wiring Location Diagram". Refer to the following for specific wire instructions.
 - External Alarm and Control Connections: See "External Alarm and Control Connections" on page 21.
 - AC Input and AC Input Equipment Grounding Connections: See "Nominal 120 VAC / 208 VAC / 220 VAC / 230 VAC / 240 VAC Input and AC Input Equipment Grounding Connections" on page 22.
 - Output Connections: See "-48 VDC Output Connections" on page 22.
 - Battery Connections: See "Battery Connections" on page 23.



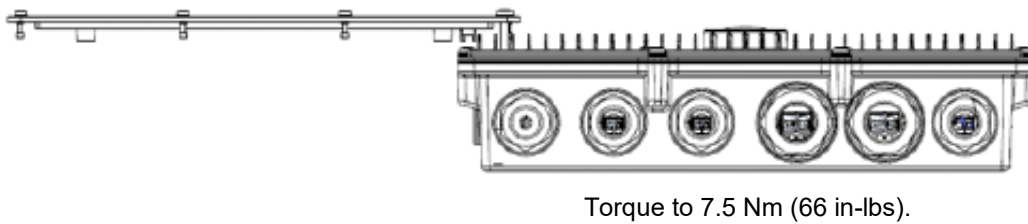
NOTE! If multiple sealing cable adapters are furnished, select and install the appropriate sealing cable adapter.

Figure 22: Connecting Customer Cables



8. Tighten the cable gland caps to secure the cables. Torque cable gland caps as indicated in **Figure 23**.

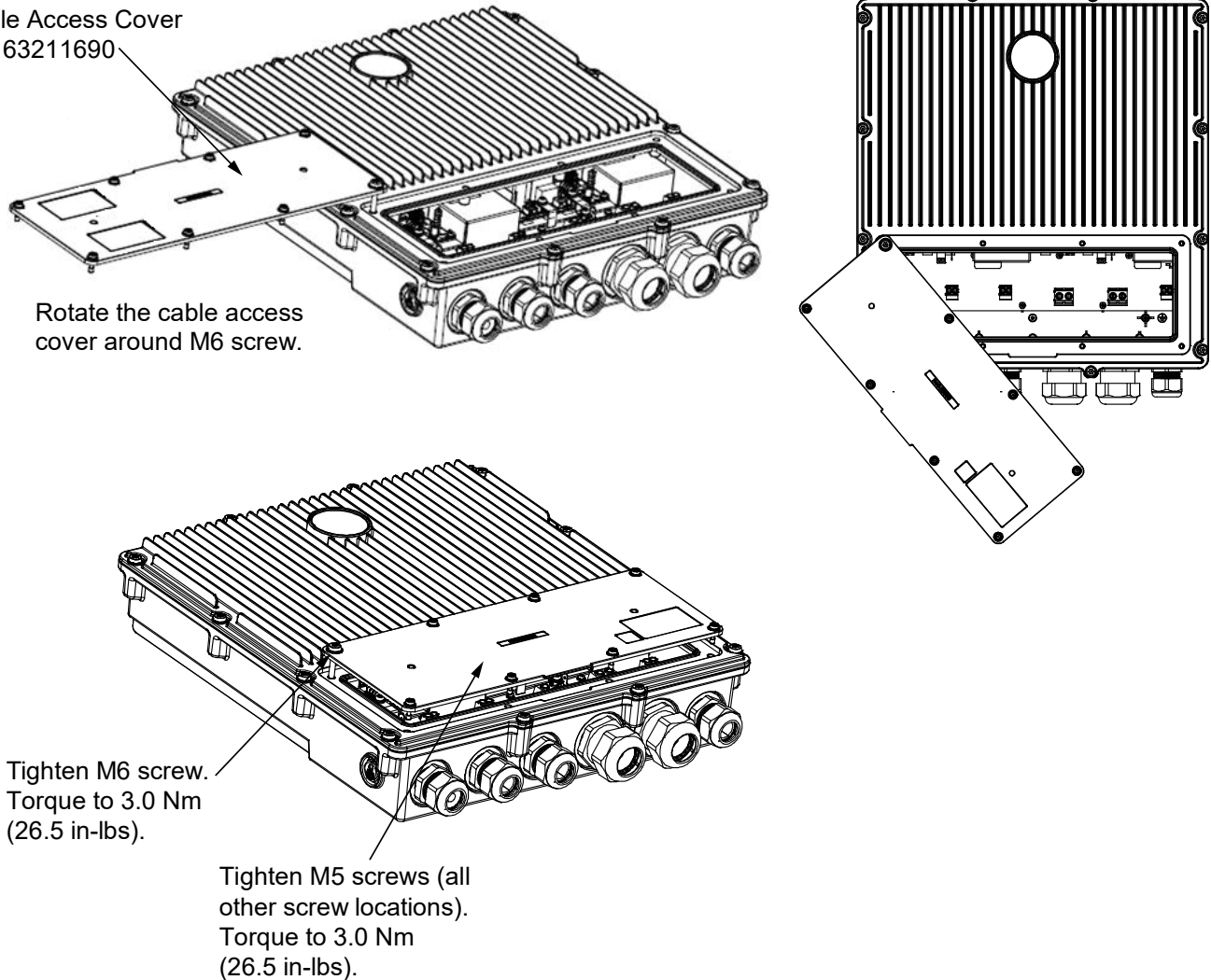
Figure 23: Tighten All of the Cable Gland Caps as Required and Torque as Indicated



9. Rotate the cable access cover counterclockwise 180° around the M6 screw. Install the screws previously removed from the cover. Tighten all screws on the cover. Torque as indicated in **Figure 24**.

Figure 24: Secure the Cable Access Cover

Cable Access Cover
P/N 63211690



Rotate the cable access cover around M6 screw.

Tighten M6 screw.
Torque to 3.0 Nm
(26.5 in-lbs).

Tighten M5 screws (all other screw locations).
Torque to 3.0 Nm
(26.5 in-lbs).

3.5 External Alarm and Control Connections

3.5.1 General

The rectifier is equipped with external alarm connection terminal blocks (located on the connector board inside the rectifier). Mating connectors are provided. Customer must provide wiring to the mating connector. Maximum wire size is 22 AWG. See **Figure 25**. See also “Customer Wiring to Terminal Blocks Located Inside Rectifier Case” starting on page 16.

3.5.2 Contact Ratings (UL / CSA Rating):



NOTE! To remain NEBS compliant, the alarm contacts must remain below 60 volts and 100 VA.

- Maximum Switching Power: 60 W, 125 VA.
- Maximum Switching Voltage: 220 VDC, 250 VAC.

- Maximum Switching Current: 2 A.
- Maximum Carrying Current: 2 A.

3.5.3 Rectifier Fail Alarm

A rectifier fail alarm activates if any of the following conditions occur. Contacts close between terminals J1-1 and J1-2 on the alarm connector during a rectifier fail alarm condition.

- Severe load sharing imbalance.
- Rectifier output disabled for any reason, including overvoltage shutdown and internal output fuse open.

3.5.4 AC Fail Alarm

An AC fail alarm activates if AC input voltage is lost.

Contacts close between terminals J2-1 and J2-2 on the alarm connector during an AC fail alarm condition.

3.5.5 Fuse Alarm

A fuse alarm activates if any of the internal fuses open.

Contacts close between terminals J7-1 and J7-2 on the alarm connector during a fuse alarm condition.

3.5.6 CAN

Terminal CAN+ on the Alarm Connector: CAN_H (associated with J4-1).

Terminal CAN- on the Alarm Connector: CAN_L (associated with J4-2).

3.6 Nominal 120 VAC / 208 VAC / 220 VAC / 230 VAC / 240 VAC Input and AC Input Equipment Grounding Connections

The rectifier is equipped with AC input terminal blocks (located on the connector board inside the rectifier). Mating connectors are provided. Customer must provide wiring to the mating connector. See **Figure 25**. Torque as indicated in **Figure 22**. See also “Customer Wiring to Terminal Blocks Located Inside Rectifier Case” starting on page 16.

- Recommended AC input wire size is 12 AWG.
- This rectifier requires an external AC input branch circuit protective device rated for 25 A.

3.7 -48 VDC Output Connections



WARNING! Check for correct polarity before making connections.

The rectifier is equipped with DC output terminal blocks (located on the connector board inside the rectifier). Mating connectors are provided. Customer must provide wiring to the mating connector. See **Figure 25**. Torque as indicated in **Figure 22**. See also “Customer Wiring to Terminal Blocks Located Inside Rectifier Case” starting on page 16.

3.8 Battery Connections

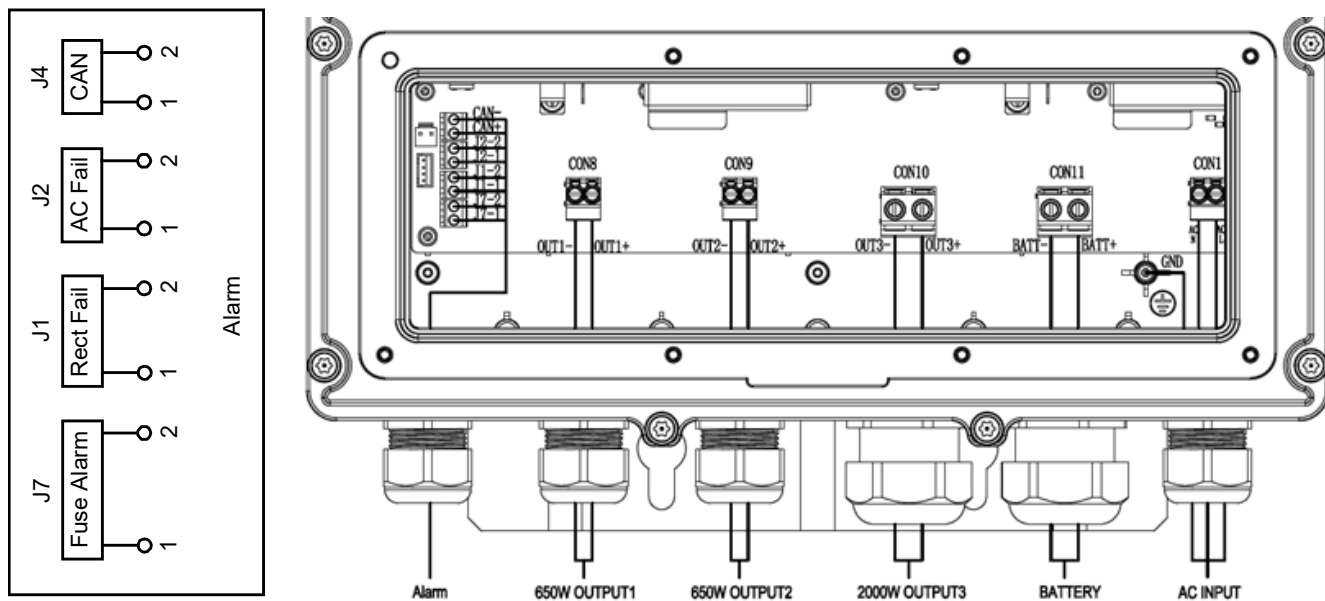


WARNING! Check for correct polarity before making connections.

The rectifier is equipped with battery terminal blocks (located on the connector board inside the rectifier). Mating connectors are provided. Customer must provide wiring to the mating connector and battery as required. See **Figure 25**. Torque as indicated in **Figure 22**. See also “Customer Wiring to Terminal Blocks Located Inside Rectifier Case” starting on page 16.

- Wire size is determined by site requirements.

Figure 25: Customer Wiring Location Diagram



Cable Gland Information		<u>Designation</u>	<u>Cable Selection</u>
<u>Designation</u>	<u>Vertiv P/N</u>	Alarm	UL2464 22 AWG*8C
Alarm	63204186	DC Output 1	SJOOW 300V 10 AWG 2/C
DC Output 1	63204183	DC Output 2	SJOOW 300V 10 AWG 2/C
DC Output 2	63204183	DC Output 3	SJOOW 600V 6 AWG 2/C
DC Output 3	63204185	Battery	SJOOW 600V 6 AWG 2/C
Battery	63204185	AC Input	SJOOW 300V 12 AWG 3/C
AC Input	63204183		

3.9 Paralleling Rectifiers for Redundancy

DO NOT EXCEED THE LOAD RATING OF A SINGLE RECTIFIER.

To parallel rectifiers, connect the CAN bus of each rectifier together. Connect CAN_H to CAN_H and CAN_L to CAN_L.

4 Initially Starting the Rectifier

Procedure

1. Apply rectifier AC input power to the system by closing the external AC disconnect or protective device. The rectifier automatically starts.

5 Operation

5.1 Rectifier High Voltage Shutdown and Lockout Restart

Procedure

1. Remove AC input power to the rectifier. Wait 30 seconds or more. Re-apply AC input power to the rectifier.

6 Troubleshooting and Repair

6.1 Contact Information

Refer to Section 4154 (provided with your customer documentation) for support contact information.

6.2 Troubleshooting

6.2.1 Rectifier Current Sharing Imbalance

When multiple rectifiers are operating in parallel and the load is greater than 20%, if the current sharing imbalance among them is greater than 3%, replace the rectifier exhibiting the current imbalance.

6.3 Repair

When a trouble symptom is localized to a faulty rectifier, the rectifier should be replaced in its entirety. No attempt should be made to troubleshoot or repair individual components inside the rectifier enclosure.

Connect with Vertiv on Social Media



<https://www.facebook.com/vertiv/>



<https://www.instagram.com/vertiv/>



<https://www.linkedin.com/company/vertiv/>



<https://www.twitter.com/vertiv/>



Vertiv.com | Vertiv Headquarters, 1050 Dearborn Drive, Columbus, OH, 43085, USA

© 2022 Vertiv Group Corp. All rights reserved. Vertiv™ and the Vertiv logo are trademarks or registered trademarks of Vertiv Group Corp. All other names and logos referred to are trade names, trademarks or registered trademarks of their respective owners. While every precaution has been taken to ensure accuracy and completeness here, Vertiv Group Corp. assumes no responsibility, and disclaims all liability, for damages resulting from use of this information or for any errors or omissions. Specifications, rebates and other promotional offers are subject to change at Vertiv's sole discretion upon notice.