



NetSure™

-48V DC Power System

Installation Manual (Section 6016), Revision K

Specification Number: 582140001

Model Number: 801NLDB, 801NLEB, 801NL-B

The information contained in this document is subject to change without notice and may not be suitable for all applications. While every precaution has been taken to ensure the accuracy and completeness of this document, Vertiv Group Corporation assumes no responsibility and disclaims all liability for damages resulting from use of this information or for any errors or omissions. Refer to other local practices or building codes as applicable for the correct methods, tools, and materials to be used in performing procedures not specifically described in this document.

This document may contain confidential and/or proprietary information of Vertiv Group Corporation, and its receipt or possession does not convey any right to reproduce, disclose its contents, or to manufacture or sell anything that it may describe. Reproduction, disclosure, or use without specific authorization from Vertiv Group Corporation is strictly prohibited.

Vertiv and the Vertiv logo are trademarks or registered trademarks of Vertiv Group Corporation. NetPerform™, NetReach™, NetSure™ and NetXtend™ are trademarks of Vertiv Energy Systems, Inc. All other trademarks are the property of their respective owners.

© 2017 Vertiv Energy Systems, Inc. All rights reserved.

TABLE OF CONTENTS

Admonishments Used in this Document.....	5
Important Safety Instructions	6
General Safety	6
Voltages.....	6
AC Input Voltages.....	6
DC Output and Battery Voltages	6
Battery	7
Personal Protective Equipment (PPE).....	8
Hazardous Voltage.....	8
Handling Equipment Containing Static Sensitive Components.....	8
Maintenance and Replacement Procedures.....	8
Static Warning.....	9
FCC Information.....	10
Customer Documentation Package.....	11
Installation Acceptance Checklist.....	11
Placing the Bays	13
General Requirements.....	13
Placing and Securing the Bays.....	14
Installing Distribution Devices, MCA Circuit Cards, and LMS Circuit Cards.....	16
Installing Distribution Fuses and Circuit Breakers.....	16
Installing MCA and LMS Circuit Cards.....	29
Making Electrical Connections.....	33
Observe the Following Admonishments.....	33
Wiring Considerations.....	33
Distribution Bay BAT RTN Connection to System Monitoring and Control Section.....	36
MCA Battery Charge Digital Temperature Compensation Probe Connection.....	36
MCA CAN Bus Port Connection.....	36
MCA External Alarm, Reference, and Control Connections and MCA I/O Circuit Card Connections.....	38
LMS Connections (if LMS Furnished).....	50
Bay Frame Grounding Connections.....	58
Load Connections.....	61
AC Input and AC Input Ground Connections.....	66
Battery Connections.....	75
Re-Install Shields and Cover Panels.....	78
MCA “Alternate Current Limit” Feature.....	79
MCA “Power Share” Feature.....	80
Connecting the 582140001 System to Other Systems.....	84

Installing the Rectifier Modules and Initially Starting the Power System.....	92
Installing the Rectifier Modules.....	92
Setting Switch S1 on the MCA Circuit Card in the Primary Power Bay.....	94
Setting Jumper J4 on MCA Distribution Bus Monitoring Circuit Cards.....	94
Initially Starting, Configuring, and Checking System Operation.....	98
Observe the Following Admonishment.....	98
MCA (Meter, Control, Alarm Panel).....	98
Initial Startup Preparation.....	103
Initially Starting the System.....	103
MCA Initialization.....	103
Checking the Inventory and Setting the Number of PCU (Rectifier) Positions Available in the System.....	107
Mapping PCU (Rectifier) Location.....	108
Setting the Date and Time.....	109
Setting the Temperature Units (Degrees C or Degrees F).....	110
Setting and Testing MCA Customer Alarm Relays (and MCA Relay Function Channels).....	110
Setting MCA I/O Circuit Card Parameters.....	112
Checking Manual Test/Equalize and Manually Initiated Timed Test/Equalize.....	113
Checking Remote High Voltage Shutdown and Rectifier Module Emergency Shutdown (ESTOP) Inputs.....	115
Checking Remote High Voltage Shutdown.....	116
Checking Emergency Shutdown and Fire Alarm Disconnect.....	116
Checking Remote Test/Equalize.....	117
Checking MCA Audible Alarm and MCA Audible Alarm Cutoff.....	117
Checking System High Voltage Alarm 1.....	119
Checking System High Voltage Alarm 2.....	119
Checking System Battery Is On Discharge Alarm.....	120
Checking Very Low Voltage Alarm.....	121
Checking Total Distribution Load Alarm.....	122
Checking Distribution Group A Load Alarm.....	123
Checking Distribution Group B Load Alarm.....	124
Checking Fuse Alarm/Circuit Breaker Alarm.....	125
Checking Metering Functions.....	126
Checking System Status.....	128
Checking and Configuring THE LMS System.....	129

ADMONISHMENTS USED IN THIS DOCUMENT



DANGER! Warns of a hazard the reader **will** be exposed to that will **likely** result in death or serious injury if not avoided. (ANSI, OSHA)



WARNING! Warns of a potential hazard the reader **may** be exposed to that **could** result in death or serious injury if not avoided. This admonition is not used for situations that pose a risk only to equipment, software, data, or service. (ANSI)



CAUTION! Warns of a potential hazard the reader **may** be exposed to that **could** result in minor or moderate injury if not avoided. (ANSI, OSHA) This admonition is not used for situations that pose a risk only to equipment, data, or service, even if such use appears to be permitted in some of the applicable standards. (OSHA)



ALERT! Alerts the reader to an action that **must be avoided** in order to protect equipment, software, data, or service. (ISO)



ALERT! Alerts the reader to an action that **must be performed** in order to prevent equipment damage, software corruption, data loss, or service interruption. (ISO)



FIRE SAFETY! Informs the reader of fire safety information, reminders, precautions, or policies, or of the locations of fire-fighting and fire-safety equipment. (ISO)



SAFETY! Informs the reader of general safety information, reminders, precautions, or policies not related to a particular source of hazard or to fire safety. (ISO, ANSI, OSHA)

IMPORTANT SAFETY INSTRUCTIONS

General Safety



DANGER! YOU MUST FOLLOW APPROVED SAFETY PROCEDURES.

Performing the following procedures may expose you to hazards. These procedures should be performed by qualified technicians familiar with the hazards associated with this type of equipment. These hazards may include shock, energy, and/or burns. To avoid these hazards:

- a) The tasks should be performed in the order indicated.
- b) Remove watches, rings, and other metal objects.
- c) Prior to contacting any uninsulated surface or termination, use a voltmeter to verify that no voltage or the expected voltage is present. Check for voltage with both AC and DC voltmeters prior to making contact.
- d) Wear eye protection.
- e) Use certified and well maintained insulated tools. Use double insulated tools appropriately rated for the work to be performed.

Voltages

AC Input Voltages



DANGER! This system operates from AC input voltage capable of producing fatal electrical shock. AC input power must be completely disconnected from the branch circuits wiring used to provide power to the system before any AC electrical connections are made. Follow local lockout/tagout procedures to ensure upstream branch circuit breakers remain de-energized during installation. DO NOT apply AC input power to the system until all electrical connections have been completed and checked.

DC Output and Battery Voltages



DANGER! This system produces DC power and may have a battery source connected to it. Although the DC voltage is not hazardously high, the rectifiers and/or battery can deliver large amounts of current. Exercise extreme caution not to inadvertently contact or have any tool inadvertently contact an output terminal or battery terminal or exposed wire connected to an output terminal or battery terminal. NEVER allow a metal object, such as a tool, to contact more than one termination or battery terminal at a time, or to simultaneously contact a termination or battery terminal and a grounded object. Even a momentary short circuit can cause sparking, explosion, and injury.



DANGER! Follow local lockout/tagout procedures to ensure DC branch circuit protection devices remain de-energized during installation at loads, as required.

Battery

Refer to the battery manufacturer documentation for specific battery safety instructions. The following are general guidelines.



WARNING! Correct polarity must be observed when connecting battery leads.



WARNING! Special safety precautions are required for procedures involving handling, installing, and servicing batteries. Observe all battery safety precautions in this manual and in the battery instruction manual. These precautions should be followed implicitly at all times.



WARNING! A battery can present a risk of electrical shock and high short circuit current. Servicing of batteries should be performed or supervised only by properly trained and qualified personnel knowledgeable about batteries and the required precautions.

The following precautions should be observed when working on batteries:

- Remove watches, rings, and other metal objects.
- Eye protection should be worn to prevent injury from accidental electrical arcs.
- Use certified and well maintained insulated tools. Use double insulated tools appropriately rated for the work to be performed. Ensure that wrenches with more than one working end have only one end exposed.
- Do not lay tools or metal parts on top of batteries.
- Disconnect charging source prior to connecting or disconnecting battery terminals.
- Risk of explosion if battery is replaced with an incorrect type or if polarity is reversed. Recommended to replace batteries with the same manufacturer and type, or equivalent.
- Dispose of used batteries according to the instructions provided with the batteries. Do not dispose of batteries in a fire. They may explode.
- ALWAYS FOLLOW THE BATTERY MANUFACTURER'S RECOMMENDATIONS AND SAFETY INSTRUCTIONS.



DANGER! This equipment may be used in conjunction with lead-acid batteries. Working near lead-acid batteries is dangerous!

In addition to the hazard of electric shock, gas produced by batteries can be explosive and sulfuric acid can cause severe burns.

- Do not open or mutilate batteries. Released electrolyte is harmful to the skin and eyes, and is toxic.
- Batteries contain sulfuric acid.
- Batteries generate explosive gases during normal operation. Systems containing batteries should never be installed in an airtight room or space. Only install in a ventilated environment.
- Batteries are an energy source that can produce high amounts of electrical current.

FOR THESE REASONS, IT IS OF CRITICAL IMPORTANCE THAT YOU READ THESE INSTRUCTIONS AND FOLLOW THEM EXACTLY.

WHEN WORKING WITH LEAD-ACID BATTERIES:

- Follow the recommended PPE requirements per the SDS for the battery to be used.
- If battery acid enters your eye, immediately flush your eye with running cold water for at least 15 minutes. Get medical attention immediately.
- If battery acid contacts skin or clothing, wash immediately with soap and water.



ALERT! Performing maintenance and/or troubleshooting procedures may interrupt power to the loads, if battery reserve is not sufficient.

Personal Protective Equipment (PPE)



DANGER! ARC FLASH AND SHOCK HAZARD.

Appropriate PPE and tools required when working on this equipment. An appropriate flash protection boundary analysis should be done determine the “hazard/risk” category, and to select proper PPE.



This product is intended only for installation in a Restricted Access Location.

Only authorized and properly trained personnel should be allowed to install, inspect, operate, or maintain the equipment.

Do not work on LIVE parts. If required to work or operate live parts, obtain appropriate Energized Work Permits as required by the local authority, per NFPA 70E “Standard for Electrical Safety in the Workplace”.

Hazardous Voltage



DANGER! HAZARD OF ELECTRICAL SHOCK.

More than one disconnect may be required to de-energize the system before servicing.

Handling Equipment Containing Static Sensitive Components



ALERT! Installation or removal of equipment containing static sensitive components requires careful handling. Before handling any equipment containing static sensitive components, read and follow the instructions contained on the Static Warning Page.

Maintenance and Replacement Procedures



CAUTION! When performing any step in procedures that requires removal or installation of hardware, use caution to ensure no hardware is dropped and left inside the unit; otherwise service interruption or equipment damage may occur.



NOTE! When performing any step in procedures that requires removal of existing hardware, retain all hardware for use in subsequent steps, unless otherwise directed.

STATIC WARNING



This equipment contains static sensitive components. The warnings listed below must be observed to prevent damage to these components. Disregarding any of these warnings may result in personal injury or damage to the equipment.

1. Strictly adhere to the procedures provided in this document.
2. Before touching any equipment containing static sensitive components, discharge all static electricity from yourself by wearing a wrist strap grounded through a one megohm resistor. Some wrist straps have a built-in one megohm resistor; no external resistor is necessary. Read and follow wrist strap manufacturer's instructions outlining use of a specific wrist strap.
3. Do not touch traces or components on equipment containing static sensitive components. Handle equipment containing static sensitive components only by the edges that do not have connector pads.
4. After removing equipment containing static sensitive components, place the equipment only on conductive or anti-static material such as conductive foam, conductive plastic, or aluminum foil. Do not use ordinary Styrofoam™ or ordinary plastic.
5. Store and ship equipment containing static sensitive components only in static shielding containers.
6. If necessary to repair equipment containing static sensitive components, wear an appropriately grounded wrist strap, work on a conductive surface, use a grounded soldering iron, and use grounded test equipment.

FCC INFORMATION

The MCA Interface Modem Option (if installed) has been granted a registration number by the Federal Communications Commission, under Part 68 rules and regulations for direct connection to the telephone lines. In order to comply with these FCC rules, the following instructions must be carefully read and applicable portions followed completely:

- a) Direct connection to the telephone lines may be made only through the standard plug-ended cord furnished to the utility installed jack. No connection may be made to party or coin phone lines. Prior to connecting the device to the telephone lines, you must:
- b) Call your telephone company and inform them you have an FCC registered device you desire to connect to their telephone lines. Give them the number(s) of the line(s) to be used, the make and model of the device, the FCC registration number and ringer equivalence. This information will be found on the device or enclosed with instructions as well as the jack suitable for your device.
- c) After the telephone company has been advised of the above you may connect your device if the jack is available, or after the telephone company has made the installation.
- d) Repairs may be made only by the manufacturer or his authorized service agency. Unauthorized repairs void registration and warranty. Contact seller or manufacturer for details of permissible user performed routine repairs, and where and how to have other than routine repairs.
- e) If, through abnormal circumstances, harm to the telephone lines is caused, it should be unplugged until it can be determined if your device or the telephone line is the source. If your device is the source, it should not be reconnected until necessary repairs are affected.
- f) Should the telephone company notify you that your device is causing harm, the device should be unplugged. The telephone company will, where practicable, notify you, that temporary discontinuance of service may be required. However, where prior notice is not practicable, the telephone company may temporarily discontinue service, if such action is reasonably necessary, in such cases the telephone company must (A) Promptly notify you of such temporary discontinuance, (B) Afford you the opportunity to correct the condition and (C) Inform you of your rights to bring a complaint to the FCC under their rules.
- g) The telephone company may make changes in its communications facilities, equipment, operations or procedures, where such action is reasonably required in the operation of its business and is not inconsistent with FCC rules. If such changes can be reasonably expected to render any customer's devices incompatible with telephone company facilities, or require modification or alteration, or otherwise materially affect its performance, written notification must be given to the user, to allow uninterrupted service.

The following information is provided here and on a label attached to the outside of the MCA Interface Modem Option (if installed).

JACK	RINGER EQUIVALENCE	FCC REGISTRATION NUMBER
RJ-11	0.2A	B46USA-22429-MM-E

CUSTOMER DOCUMENTATION PACKAGE

This document (Section 6016) provides Installation Instructions for NETSURE™ Power System Model **801NLDB** (208V Input Power Bay), **801NLEB** (380V/480V Input Power Bay), and **801NL-B** (Distribution Bay); Spec. No. **582140001**.

For *User Instructions*, refer to Section 6017 provided on the CD (Electronic Documentation Package) furnished with your system.

Refer to SAG582140001 (*System Application Guide*) for additional information. The SAG can be accessed via the CD (Electronic Documentation Package) furnished with your system.

For a color MCA Menu Tree, refer to Section 5886. Section 5886 is provided in the separate *INSTALLATION MANUAL* and the *CD CARRIER MANUAL* (it is also provided on the CD).

Your Power System may contain an optional LMS Monitoring System, refer to Section 5879 (*LMS1000 Installation Instructions*) and Section 5847 (*LMS1000 User Instructions*) provided on the CD (Electronic Documentation Package) furnished with your system.

INSTALLATION ACCEPTANCE CHECKLIST

Provided below is an Installation Acceptance Checklist. This checklist helps ensure proper installation and initial operation of the system. As the procedures presented in this document are completed, check the appropriate box in this list. If the procedure is not required to be performed for your installation site, also check the box in this list to indicate that the procedure was read. When installation is done, ensure that each block in this list has been checked. Some of these procedures may have been factory performed for you.



NOTE! *The system is not powered up until the end of this checklist.*



NOTE! *Some of these procedures may have been performed at the factory for you.*

Placing the Bays

- Bays Bolted Together (if required) and Mounted to Floor

installing Distribution Devices, MCA Relay Circuit Cards, MCA I/O Circuit Cards, and LMS Circuit Cards

- Distribution Fuses and Circuit Breakers Installed
- Distribution Lug Adapter Plates Installed, as required
- MCA Customer Alarm Relay Circuit Card(s) Installed (if required)
- MCA I/O Circuit Card(s) Installed (if required)
- LMS CPU Circuit Card Installed (if required)
- LMS Modem Circuit Card Installed (if required)
- LMS Four Input Analog Circuit Card Installed (if required) after Making any Jumper Adjustment as Required

- LMS Eight Input Analog Circuit Card Installed (if required)
- LMS Twelve Input Analog Circuit Card Installed (if required)
- LMS Four Input Binary Circuit Card Installed (if required)
- LMS Eight Input Binary Circuit Card Installed (if required)
after Making any Jumper Adjustment as Required
- LMS Four Output (Form-C) Relay Circuit Card Installed (if required)
after Making any Jumper Adjustment as Required
- LMS Eight Input Temperature Circuit Card Installed (if required)
and Ground Lead Attached to Frame Ground

Making Electrical Connections

- MCA Network Bay Interconnections Made
- MCA Battery Charge Digital Temperature Compensation Probe Mounted and Connected (if furnished)
- MCA External Alarm, Reference, and Control Connections Made
- Connections Made to all MCA I/O Circuit Cards Installed
- External LMS CPU/Hardware Fail Alarm Connections Made (as required)
- LMS Local Port Connections Made (if required)
- LMS Ethernet Port Connections Made (if required)
- LMS Modem Port Connections Made (if required)
- LMS OEM (RS-485) Port Connections Made (if required)
- Connections Made to all LMS Four Input Analog Circuit Cards Installed
- Connections Made to all LMS Eight Input Analog Circuit Cards Installed
- Connections Made to all LMS Twelve Input Analog Circuit Cards Installed
- Connections Made to all LMS Four Input Binary Circuit Cards Installed
- Connections Made to all LMS Eight Input Binary Circuit Cards Installed
- Connections Made to all LMS Four Output (Form-C) Relay Circuit Cards Installed
- Connections Made to all LMS Eight Input Temperature Circuit Cards Installed
- LMS Energy Management Connections Made (as required)
- LMS Sequential Start Connections Made (as required)
- LMS Expansion Assembly(s) (if furnished) Interconnected to Customer Equipment
- LMS Network Bay and Optional LMS Expansion Cabinet(s) and Assembly(s) Interconnections Made (as required)

- Frame Grounding Connections Made
- Load Connections Made
- AC Input and AC Input Ground Connections Made
- Battery Connections Made
- All Shields and Cover Panels Re-Installed
- MCA “Power Share” Connections Made (if required)
- Connections to Other Systems Made (if required)

Installing the Rectifier Modules and Initially Starting the Power System

- Rectifier Modules Installed
- Primary Power Bay MCA and Secondary Power Bay(s) Router Circuit Cards Switches Set
- MCA Distribution Bus Monitoring Circuit Cards Jumper Set
- System Started, Configured, and Checked
- LMS Checked and Configured (as required)

PLACING THE BAYS

General Requirements

- The installer should be familiar with the installation requirements and techniques to be used in securing the bay(s) to the floor.
- This product is intended only for installation in a Restricted Access Location on or above a non-combustible surface.
- This product is intended for installation in Network Telecommunication Facilities (CO, vault, hut, or other environmentally controlled electronic equipment enclosure).
- This product is intended to be connected to the common bonding network in a Network Telecommunication Facility (CO, vault, hut, or other environmentally controlled electronic equipment enclosure).
- Front and rear access is required for installation.
- Typical industry standards recommended minimum aisle space clearance is 2' 6" for the front of the bay(s) and 2' for the rear of the bay(s).
- Rectifier Module ventilating openings must not be blocked and temperature of air entering Rectifier Modules must not exceed rated Operating Ambient Temperature Range found in System Application Guide SAG582140001.
- The system consists of one (1) Primary Power Bay and up to six (6) Secondary Power Bays, and one (1) to eight (8) Distribution Bays; depending upon your power requirements. It is recommended to place the Primary Power Bay on the far right or far left end of the bay line-up, and to expand the system to the

left or right of the Primary Power Bay. This allows simple cable connections between bays, and a consistent MCA Bay numbering scheme. The Primary Power Bay is identified by the MCA as Bay #1. The other bays are numbered consecutively, following the bay-to-bay cabling scheme. Thus, bays are numbered #1-#15 from right to left or from left to right. The Primary Power Bay may be placed in the middle of the bay line-up, expanding the system to the left and right of the Primary Power Bay. In this configuration, bay-to-bay cabling MUST start with the Primary Power Bay, then each Secondary Power and Distribution Only Bay is daisy-chained into the cabling string. Remember, the Primary Power Bay is identified by the MCA as Bay #1, the other bays are numbered consecutively following the bay-to-bay cabling scheme.

Placing and Securing the Bays

- **Figure 1** and **Figure 2** provide floor hole drilling patterns.
- Bays are typically placed next to each other and bolted together. Refer to the previous Section, GENERAL REQUIREMENTS, for bay line-up recommendations.

Procedure

1. If bays are to be placed next to each other, remove the side cover panels from the sides that will be placed next to another bay (leaving the side cover panels on the "outside side" of the two end bays). Install side cover panels on end bays as required.
2. Place bay(s) in position. Note that clearance holes for 1/4" bolts are provided in the side rails of each bay. These holes are for bolting the bays together.
3. Remove the lower front Rectifier Module mounting position blank cover panels from each Power Bay to provide access to bay's floor mounting holes. Cover panels will be re-installed in empty Rectifier Module mounting positions after all Rectifier Modules are installed.
4. Remove the lower rear cover panel from each bay to provide access to bay's floor mounting holes. These cover panels will be re-installed after all mounting and electrical connection procedures have been completed.
5. Level bay(s) as required, using the leveling nut provided in base plate. Adjust leveling bolts so that all bays are even at top, and bolt holes in the side of each bay line up with holes in the adjacent bay(s).
6. Bolt all bays together. Use 1/4" hardware, seven places per pair of bays. Use a ground washer in two locations with the 1/4" hardware bolting two bays together.



NOTE! A ground washer is an internal-external tooth, dish-type lock washer. When installing ground washers, ensure that the ground washer is oriented so that the teeth dig into the paint on the metal part the ground washer is secured to (concave side faces the metal part).

7. Install shims between bottom of each bay and the floor as required to distribute floor loading.
8. Secure bay(s) to floor using fastening hardware per site requirements.
9. If the outside sides of the end bays do not have side cover panels, install them now (two per side). Note that ground washers are used with each screw securing the side cover panels.

Figure 1: Floor Mounting Hole Dimensions, Primary and Secondary Power Bays (all dimensions in inches)

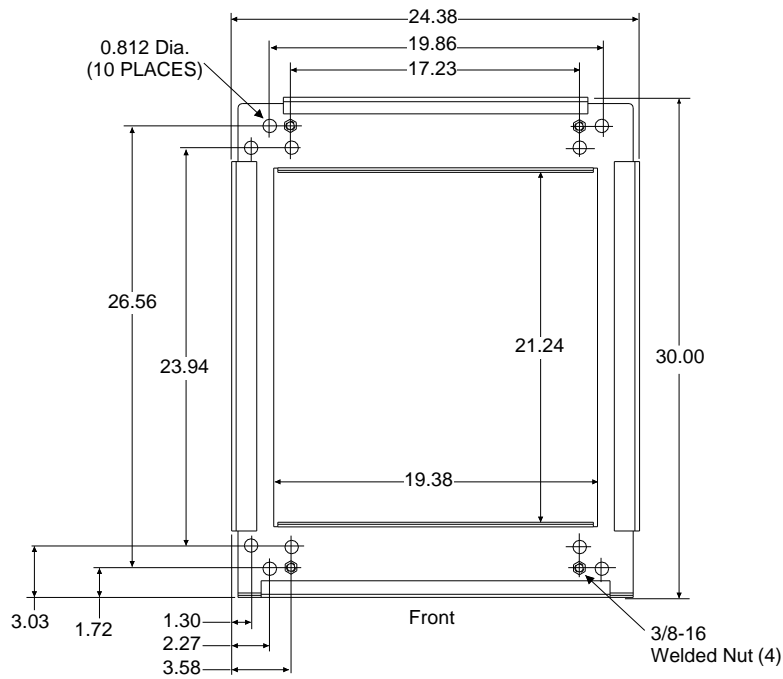
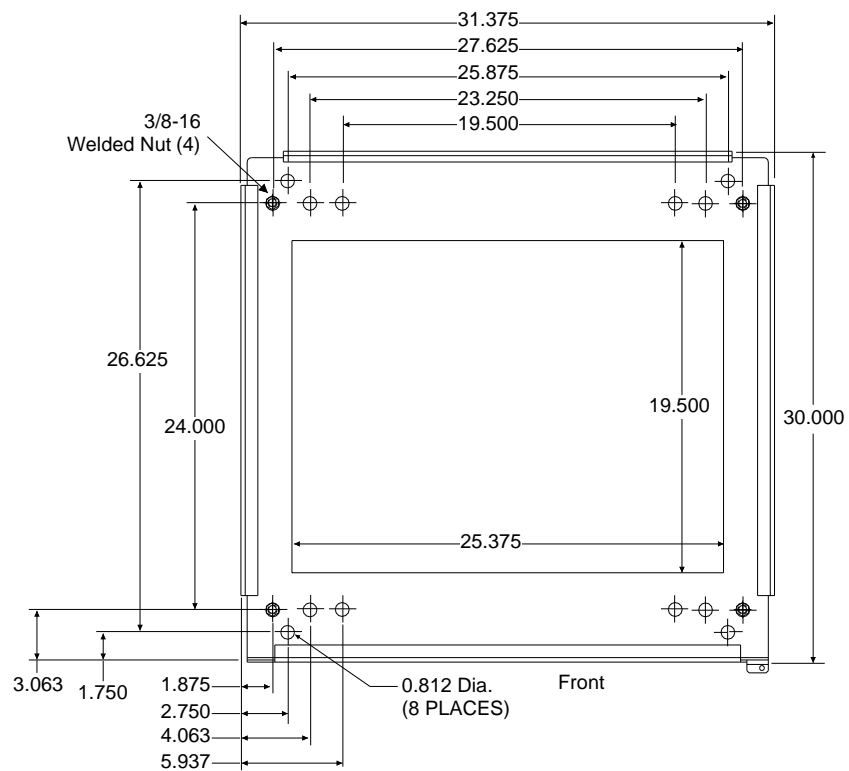



Figure 2: Floor Mounting Hole Dimensions, Distribution Bays (all dimensions in inches)



INSTALLING DISTRIBUTION DEVICES, MCA CIRCUIT CARDS, AND LMS CIRCUIT CARDS

Installing Distribution Fuses and Circuit Breakers

Installing 218 Circuit Breakers and TPL Fuseholders into Distribution Bays

 **NOTE!** Each distribution bus is divided into half, and each half **MUST** be populated with distribution devices as shown in the following illustrations, without skipping any distribution device mounting positions within each half.

Procedure

1. Orient the device over its mounting location as shown in **Figure 3**. Slide the device over the left and right mounting studs, and plug the device into the mating connector located on the bay. Ensure correct alignment of the mating pins as you plug the device in.
2. Place a Belleville lock washer and 3/8 16 nut on each inner stud. Hand-tighten.
3. Place a flat washer, lock washer, and 1/4 20 nut on each outer stud. Hand-tighten.
4. Torque the inner 3/8 16 nuts to 180 in lbs.
5. Torque the outer 1/4 20 nuts to 84 in lbs.
6. Install Load Lug Adapter plates as required. Refer to **Figure 4** for location and the numbering scheme for the load lug mounting locations. Refer to **Figure 4** through **Figure 6** for load lug adapter selection and installation details. **Note that 1 pole devices do not require load lug adapter plates.**

Installing TPL Fuses

Refer to **Figure 7**.

Procedure

1. Remove the fuseholder portion from the mounted fuseholder body by grasping its handle and pulling it straight out. Install the TPL fuse into the fuseholder portion. Secure the fuse with the flat washer, lock washer, and nut provided. Recommended torque is 168 in-lbs. When done, push the fuseholder portion securely back into the mounted fuseholder body.
2. Ensure an alarm fuse is installed in the GMT-type fuseholder located adjacent to the TPL fuseholder. The alarm fuse should be a Bussmann GMT 18/100 ampere alarm fuse. Vertiv P/N 248610301.
3. Ensure a safety fuse cover is installed on the GMT alarm fuse. Vertiv P/N 248898700.

Installing TLS/TPS Fuses

Refer to **Figure 8**.

Procedure

1. Orient the Bullet Nose-Type Fuseholder over its mounting position and firmly press to seat the bullet-type connectors.

2. Remove the fuseholder portion from the mounted fuseholder body by pulling it straight out. Install the TLS/TPS fuse into the fuseholder. When done, push the fuseholder portion back into the mounted fuseholder body.
3. Ensure an alarm fuse is installed in the GMT-type fuseholder provided on the mounted fuseholder body. The alarm fuse should be a Bussmann GMT 18/100 ampere alarm fuse. Vertiv P/N 248610301.
4. Ensure a safety fuse cover is installed on the GMT alarm fuse. Vertiv P/N 248898700.

Installing Bullet Nose-Type Circuit Breakers

Refer to **Figure 8**.

Procedure

1. Simply orient the circuit breaker over its mounting position with the ON position at top and firmly press to seat the bullet-type connectors.

Installing an Optional Bullet Nose-Type 10-Position GMT Fuse Module

Refer to the procedure *Installing and Wiring an Optional Bullet Nose-Type 10 Position GMT Fuse Module* in the “Making Electrical Connections” section.

Storing Spare Fuses

Spare fuses may be stored in holders provided inside the bay, behind the MCA Distribution Bus Monitoring circuit card hinged panels.

Recording Fuse and Circuit Breaker Sizes

Record all fuse and circuit breaker sizes installed on the cards provided on the MCA Distribution Bus Monitoring circuit card hinged panels.

Figure 3: Installing 218 Circuit Breakers and TPL Fuseholders into Distribution Bays

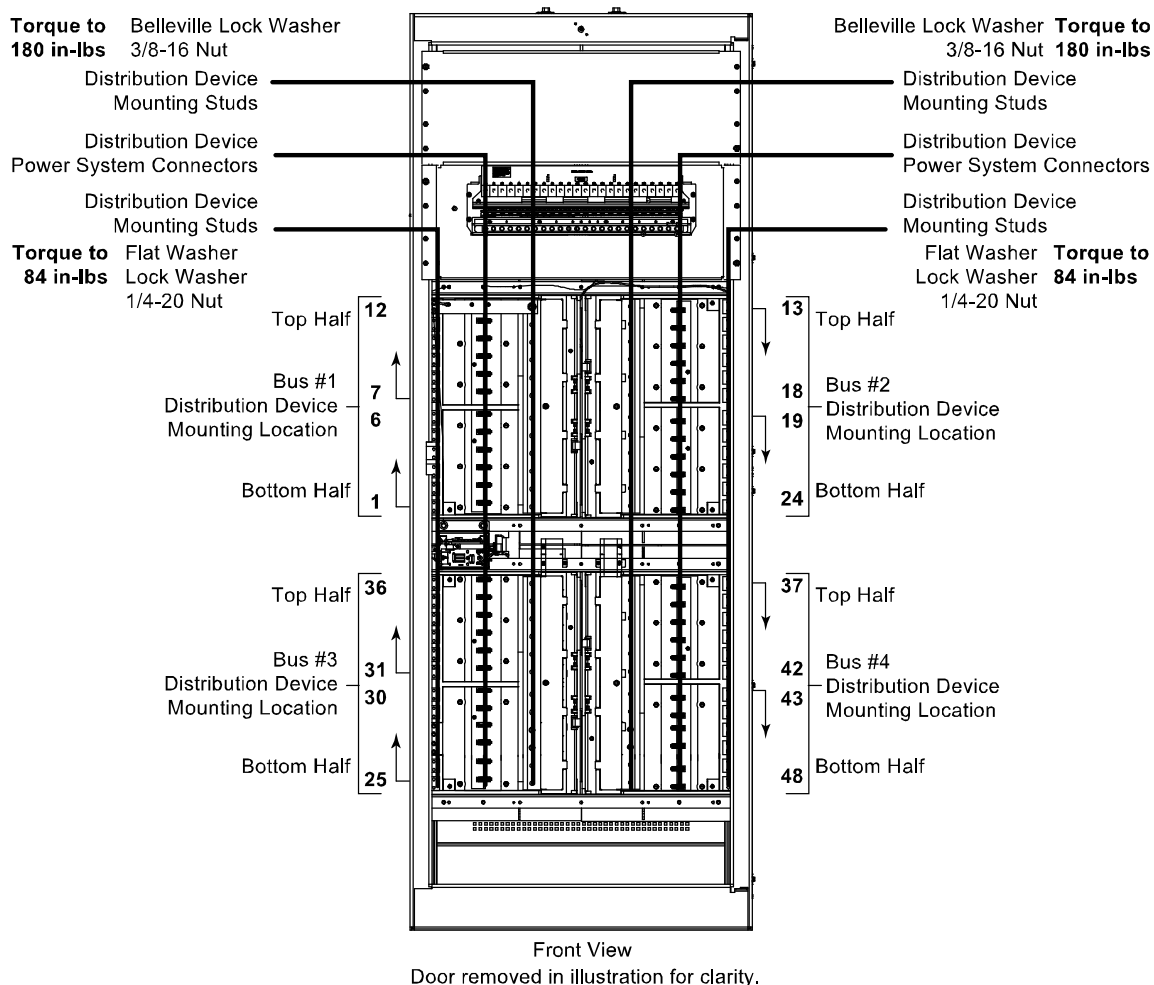

Note: On the left side, each half of each bus **MUST** be populated with distribution devices from bottom-to-top, without skipping any distribution device mounting positions within each half. (Arrows indicate starting position in each half.)

Note: On the right side, each half of each bus **MUST** be populated with distribution devices from top-to-bottom, without skipping any distribution device mounting positions within each half. (Arrows indicate starting position in each half.)

This allows automatic monitoring of each position and allow the controller to located all distribution positions.

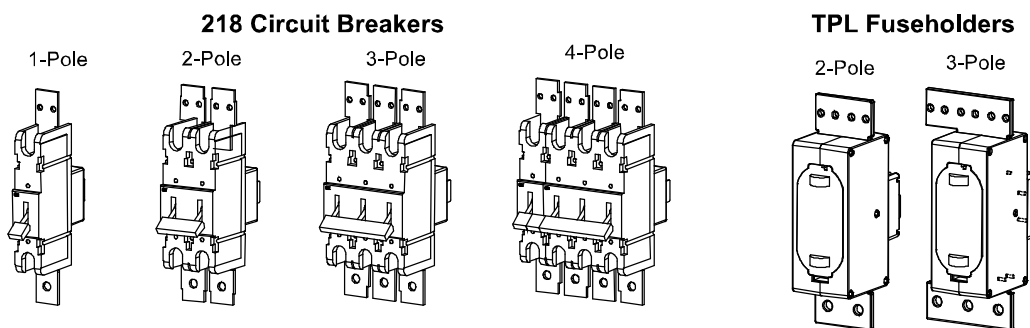

Figure 4: Installing Load Lug Adapter Plates into Distribution Bays (cont'd on next page)

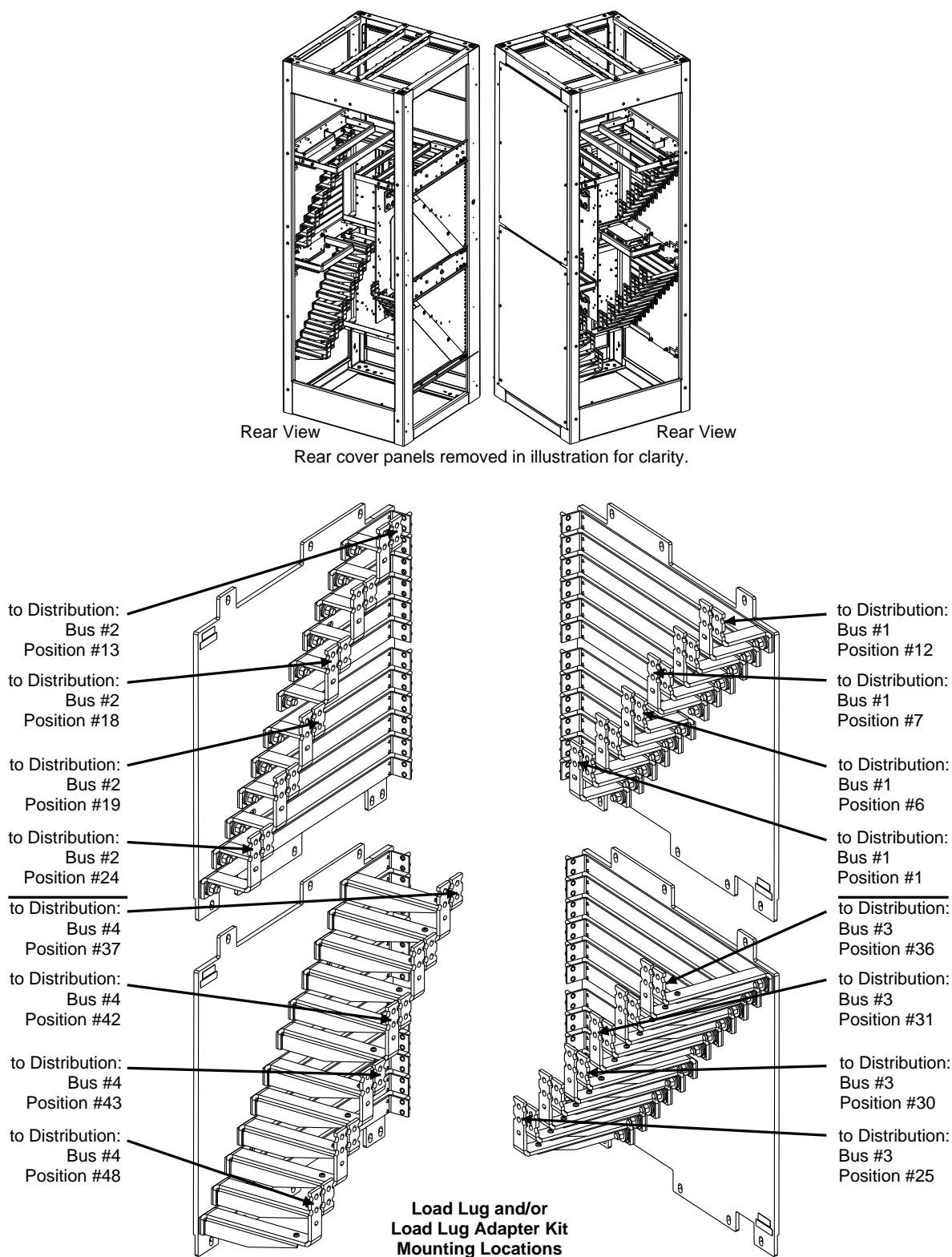
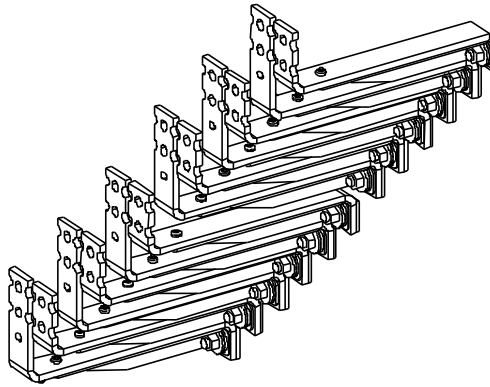
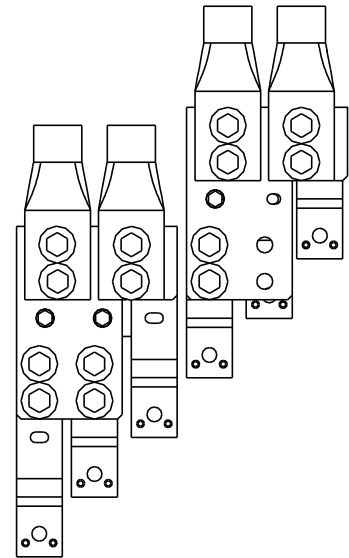

Figure 4: *Installing Load Lug Adapter Plates into Distribution Bays (cont'd from previous page, cont'd on next page)*



1-Position Devices
(Load Busbars with NO
Lug Adapters Installed)



**3-Position
Lug Adapter Kit**
P/N 529131

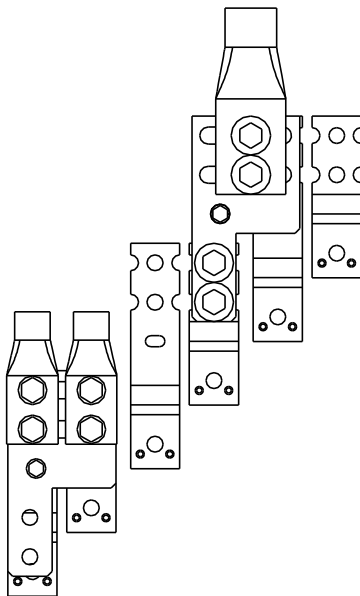

**2-Position
Lug Adapter Kit**
P/N 529132

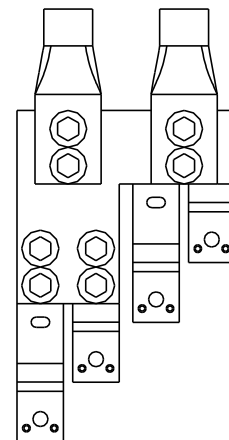

**4-Position
Lug Adapter Kit**
P/N 534420

**NOTE THAT 1-POLE 218 CIRCUIT BREAKERS
DO NOT REQUIRE LOAD LUG ADAPTER PLATES**

Figure 4: Installing Load Lug Adapter Plates into Distribution Bays (cont'd from previous page, cont'd on next page)

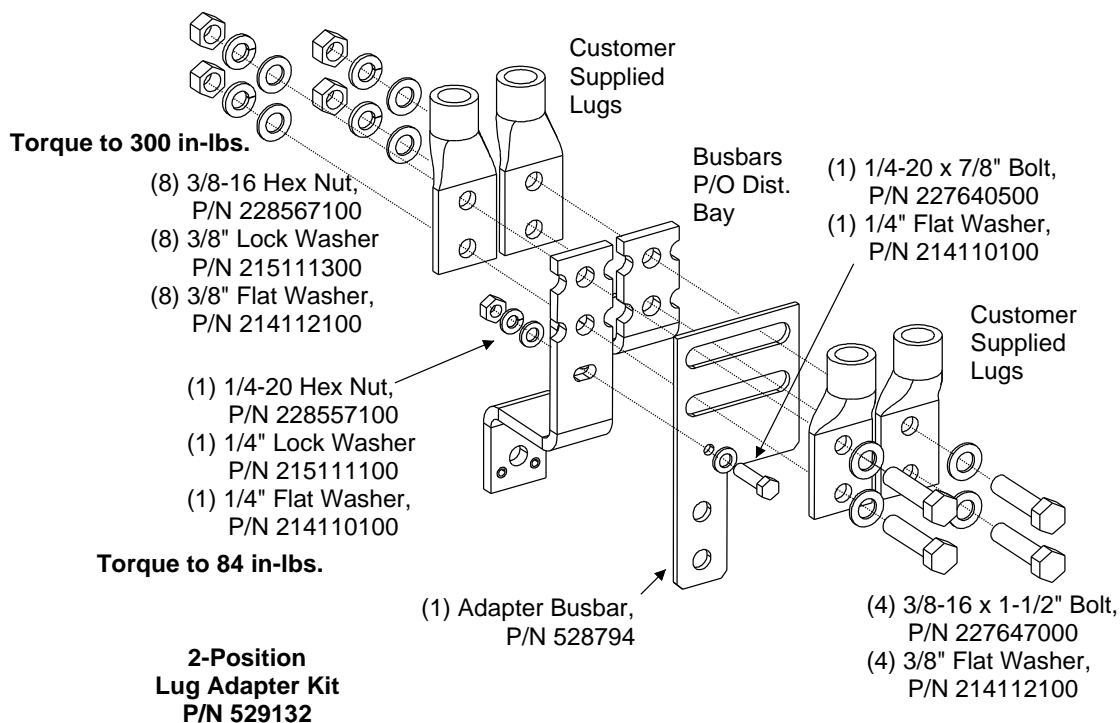
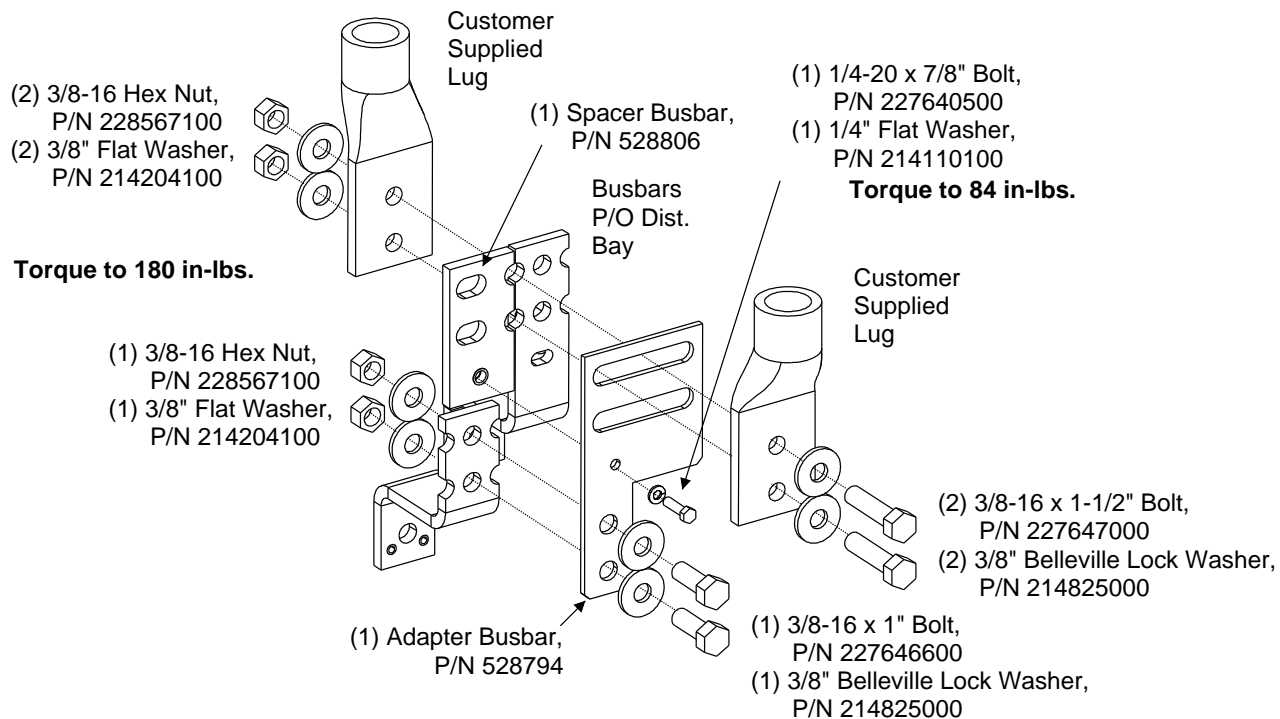

Note: Apply Electrical Anti-Oxidation Compound to all Busbar Mating Surfaces.

Note: Concave Side of Belleville Washer Faces Busbar, Convex Side Faces Bolt or Nut.

Figure 4: Installing Load Lug Adapter Plates into Distribution Bays (cont'd from previous page, cont'd on next page)

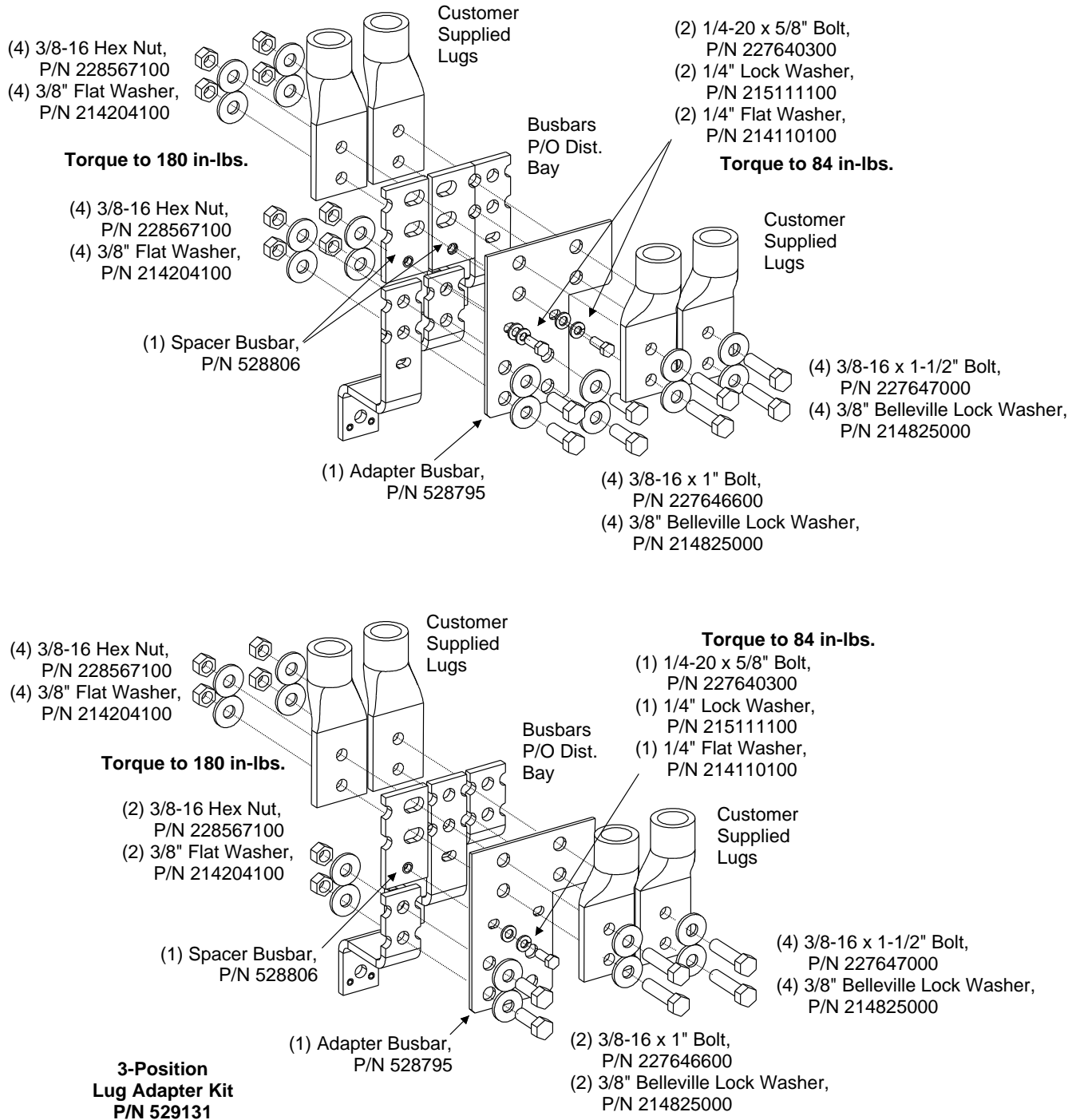

Note: Apply Electrical Anti-Oxidation Compound to all Busbar Mating Surfaces.

Note: Concave Side of Belleville Washer Faces Busbar, Convex Side Faces Bolt or Nut.

Figure 4: Installing Load Lug Adapter Plates into Distribution Bays (cont'd from previous page)

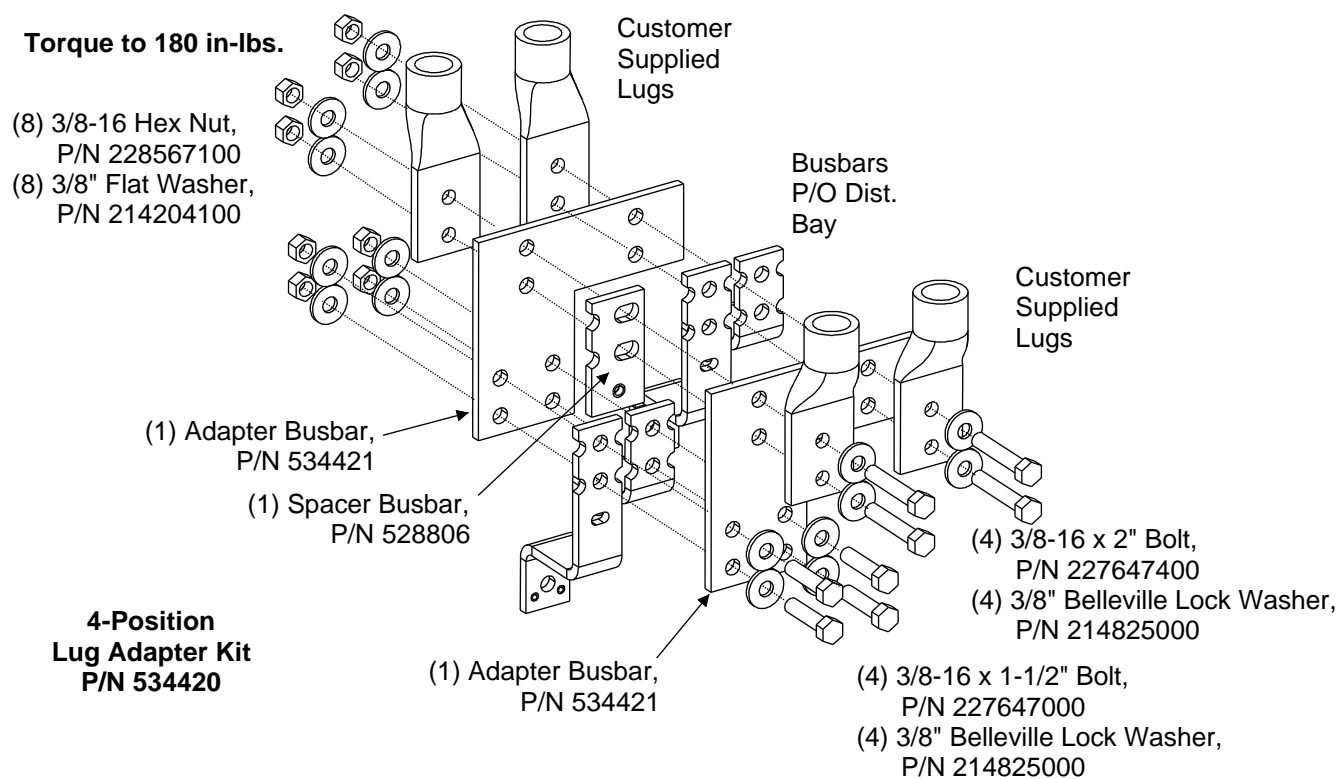

Note: Apply Electrical Anti-Oxidation Compound to all Busbar Mating Surfaces.

Note: Concave Side of Belleville Washer Faces Busbar, Convex Side Faces Bolt or Nut.

Figure 5: 218 Circuit Breakers Lug Adapter Kits

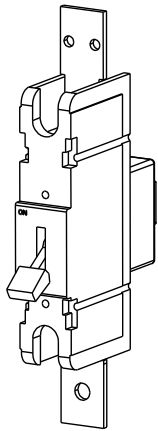

1-Pole 218 Circuit Breaker Assemblies

Lug Adapter Kit

NO LUG ADAPTER KIT REQUIRED

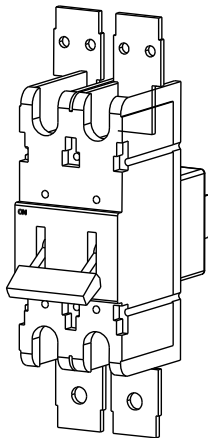

2-Pole 218 Circuit Breaker Assemblies

Lug Adapter Kit

3/8" Clearance Hole

1.000"

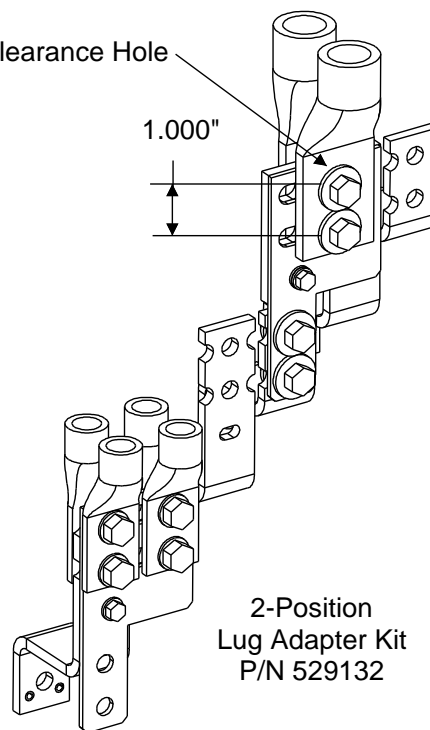

**2-Position Lug Adapter Kit
P/N 529132**

Figure 5: 218 Circuit Breakers Lug Adapter Kits

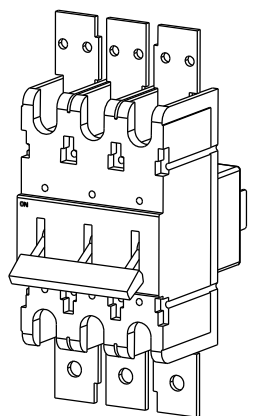

3-Pole 218 Circuit Breaker Assemblies

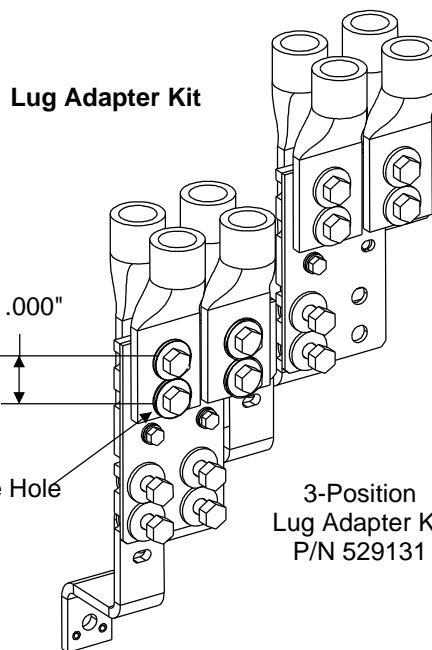

Lug Adapter Kit

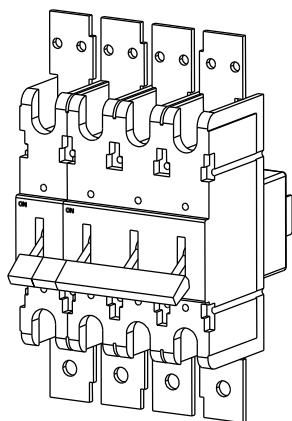

4-Pole 218 Circuit Breaker Assemblies

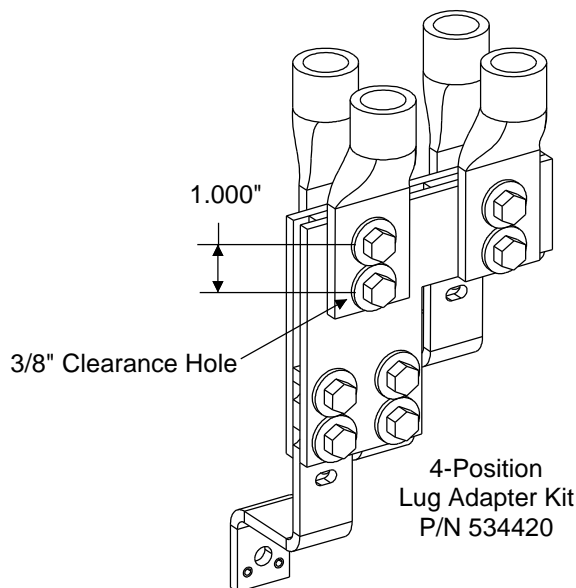

Lug Adapter Kit

Figure 6: TPL Fuses Lug Adapter Kits

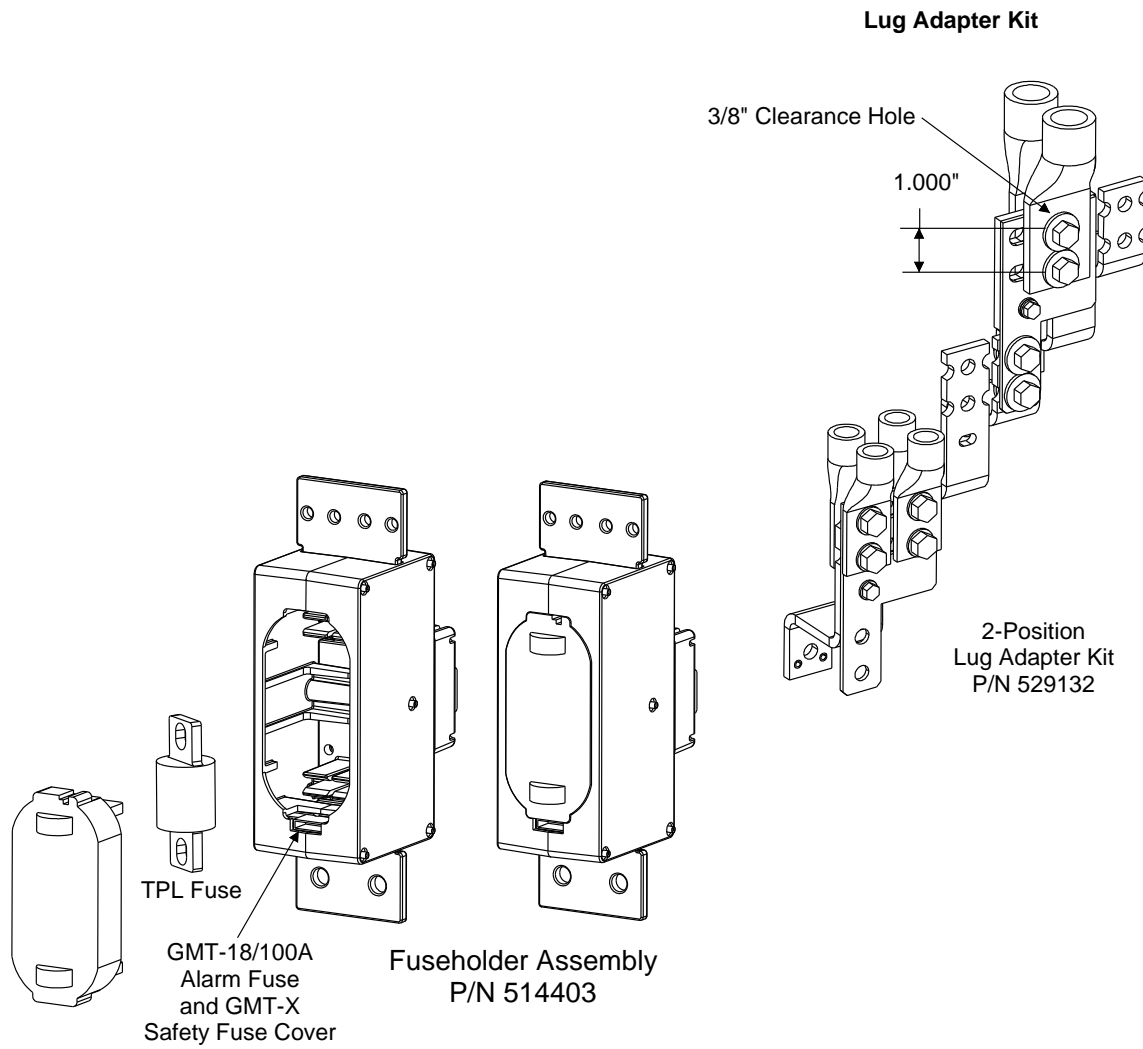

Figure 6: TPL Fuses Lug Adapter Kits

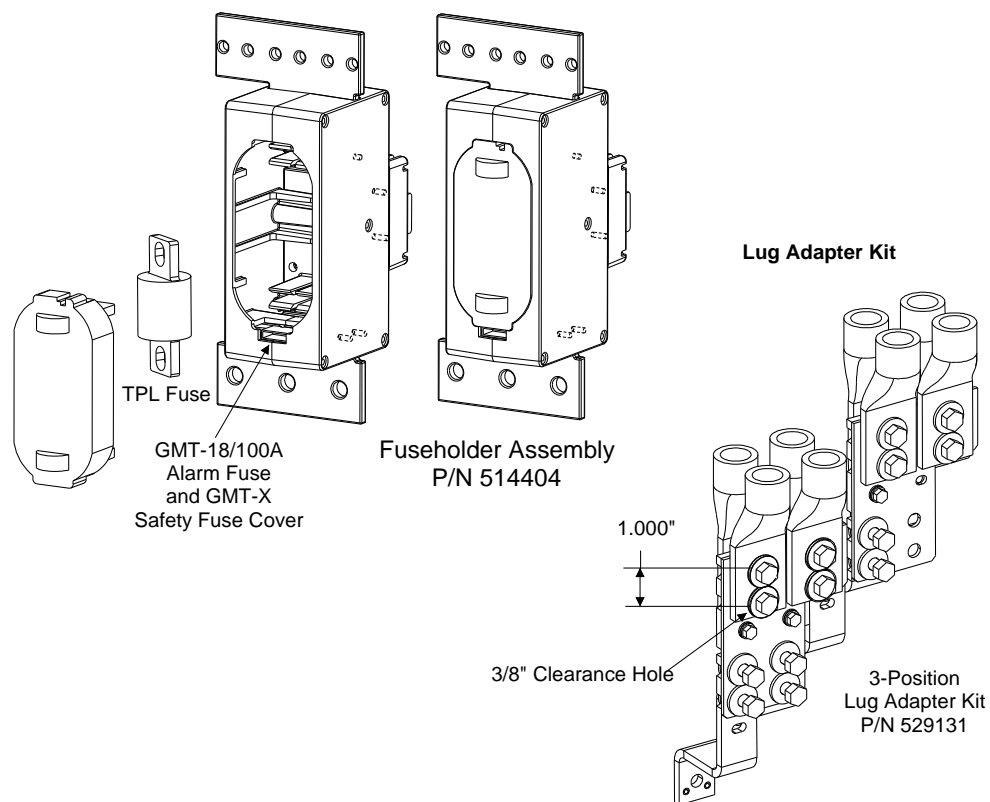

Figure 7: Installing TPL Fuses

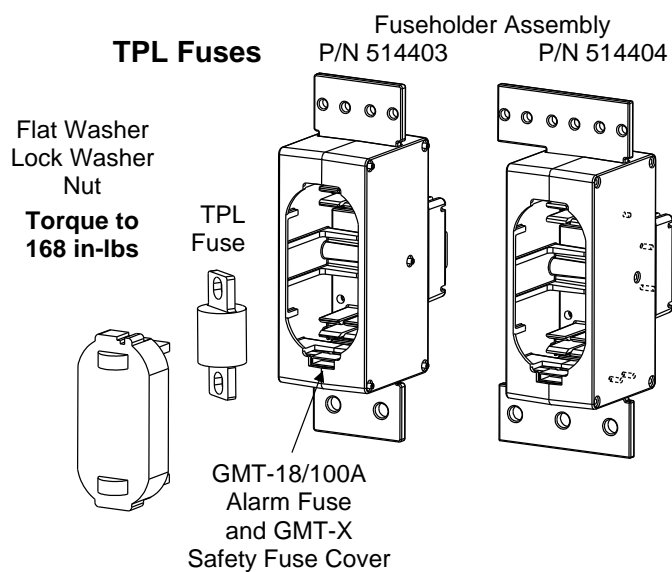
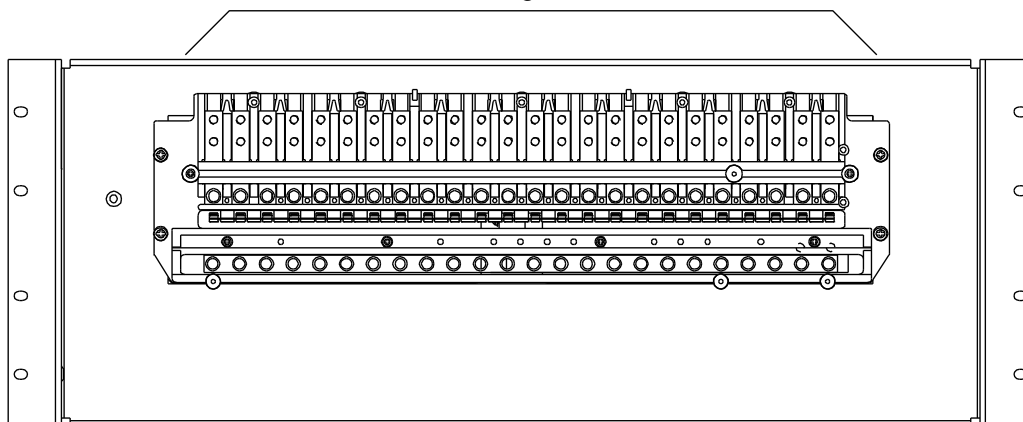
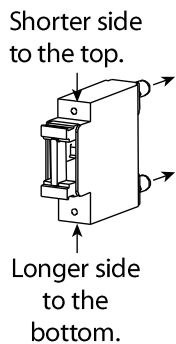
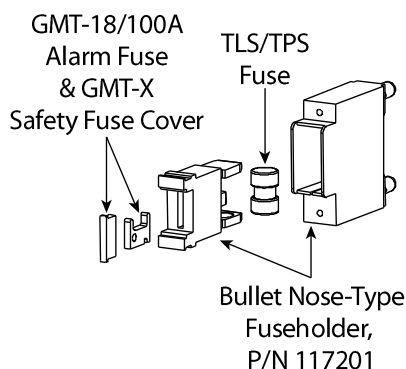

Figure 8: Installing TLS/TPS Fuses and Bullet Nose-Type Circuit Breakers

Note: Load leads are connected to load busbars. These busbars provide 1/4-20 threaded holes on 5/8" centers for installation of customer provided two-hole lugs. Customer must provide lug mounting bolts and additional hardware. Bolt length: 3/4".



TLS/TPS Fuses



Bullet Nose-Type Circuit Breakers

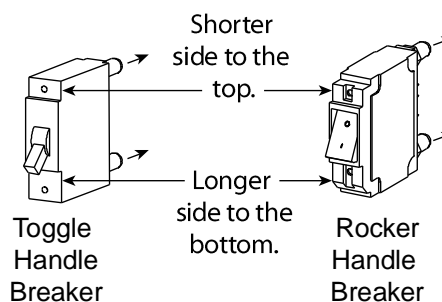

Installing MCA and LMS Circuit Cards

Circuit Card Handling



ALERT! Before handling any circuit card, read and follow the instructions contained on the Static Warning Page located at the beginning of this manual.

A static wrist strap grounded through a one megohm resistor should always be worn when handling the circuit cards.

Identifying the Circuit Cards

- a) Circuit cards can be identified through two methods as described below.
- b) The Vertiv part number printed on the outside of the shipping carton.

The Vertiv part number silkscreened on the component side of the circuit card.

Installing LMS Circuit Cards

Refer to the separate LMS *Installation Instructions* (Section 5879) for a procedure to install LMS CPU, LMS Modem, and LMS Input/Output (I/O) circuit cards. Section 5879 can be accessed from the CD (Electronic Documentation Package) furnished with your system.

Installing MCA Customer Alarm Relay Circuit Card(s) and MCA I/O Circuit Card(s)

Refer to the following procedure, and install the MCA Customer Alarm Relay circuit card(s) and MCA I/O Circuit Card(s) into the respective mounting position(s) of the Primary and Secondary Power Bay(s), as required.

Refer to **Figure 9** and **Figure 10**.

Procedure:

1. Open the bay's front door to access the MCA circuit card mounting positions.
2. Connect an approved grounding strap to your wrist. Attach the other end to a suitable ground.
3. Loosen the two screws securing the circuit card retaining angle, and slide the retaining angle down.
4. Unpack the MCA circuit card(s) to be installed.

MCA Customer Alarm Relay Circuit Card: P/N 514348.

MCA I/O Circuit Card: P/Ns 524550 and 524551.

5. Each MCA circuit card can be installed in any of the circuit card mounting positions in any bay. Circuit cards are installed in the bay with the component side facing the left as viewed from the front. Slide the circuit card(s) into its mounting location, ensuring the rear edge connector is firmly seated.



NOTE! *The recommended method is to populate LMS Input/Output circuit cards from left to right, and MCA circuit cards from right to left.*



NOTE! *If you are using the default MCA Relay Function Channel configurations and the default MCA Customer Alarm Relay assignments, refer to **Figure 15** for required card locations.*

6. When all circuit cards have been installed, slide the circuit card retaining angle up and secure by tightening the two screws.
7. When all circuit cards have been installed, remove the grounding wrist strap.

8. After all electrical connections are made close the bay's front door.
9. Save several of the static protective bags that the circuit cards were shipped in. If a circuit card is ever required to be removed from the system, it should immediately be placed in a static protective bag.

Figure 9: Circuit Card Mounting Locations

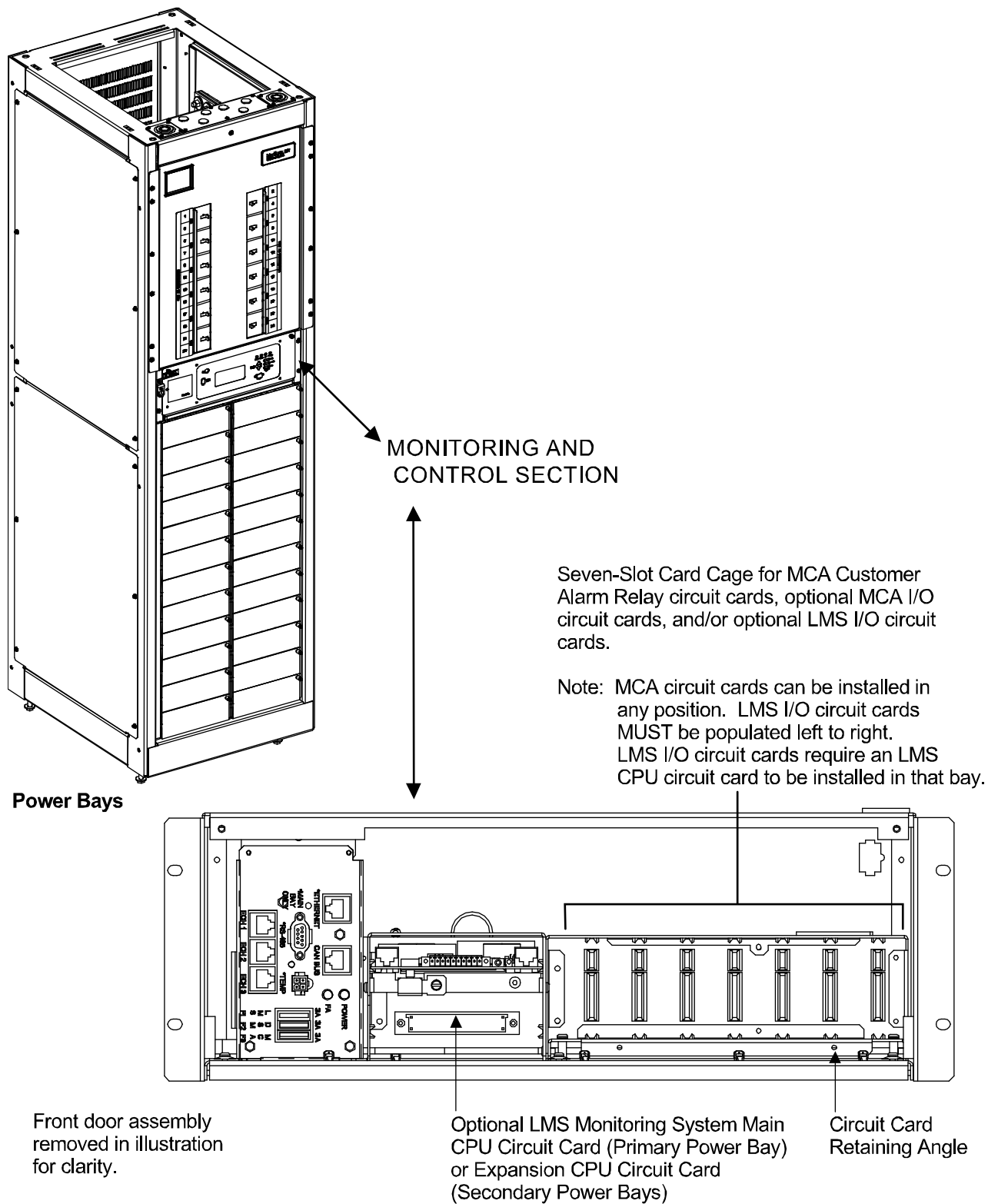
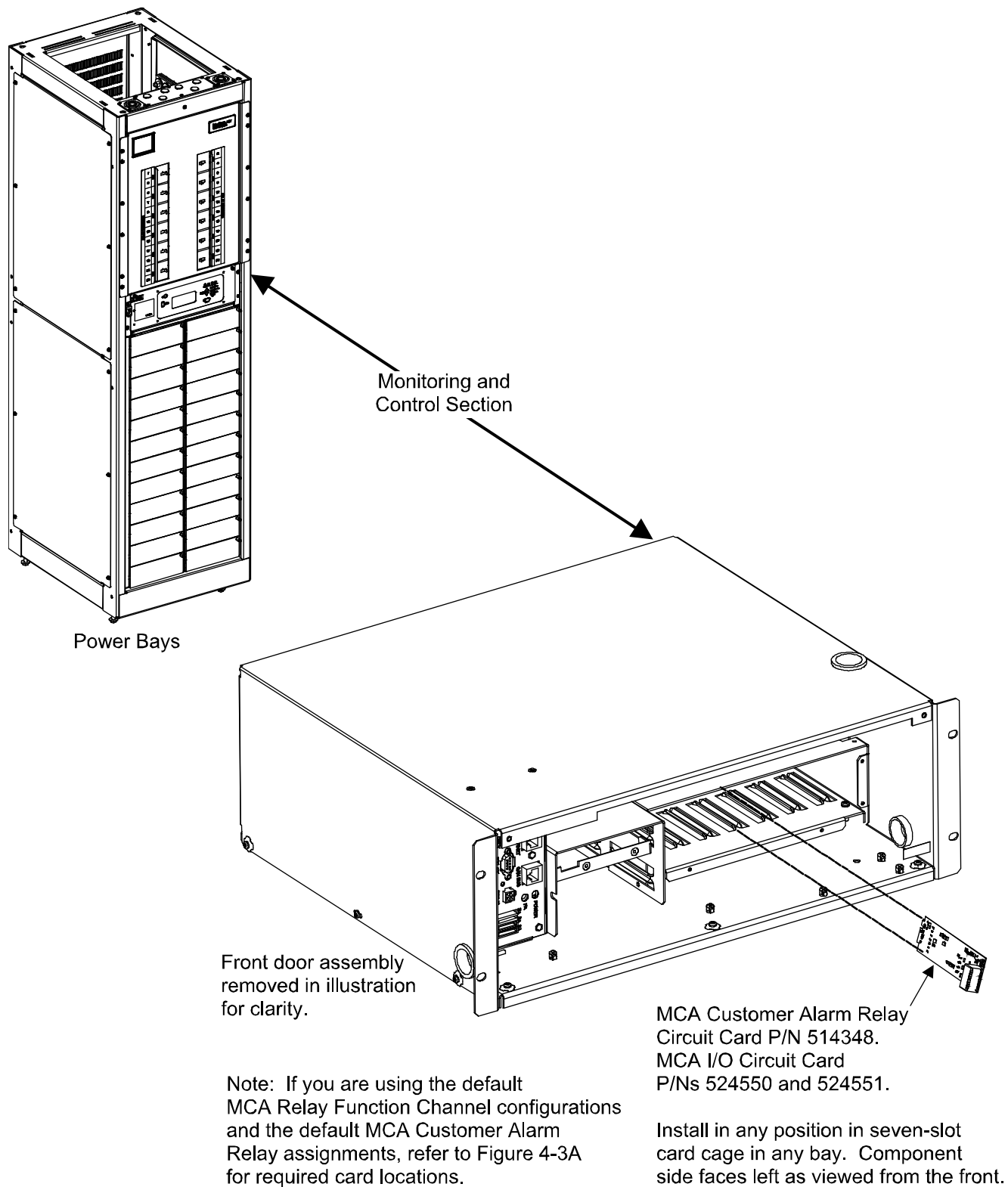

Figure 10: Installing the MCA Relay and I/O Circuit Card(s)



MAKING ELECTRICAL CONNECTIONS

Observe the Following Admonishments



DANGER! INSTALLERS MUST FOLLOW APPROVED SAFETY PROCEDURES.

This system operates from AC voltage capable of producing fatal electrical shock. AC input power must be completely disconnected from the branch circuits wiring used to provide power to the system before any electrical connections are made. DO NOT apply AC power to the system until all electrical connections have been completed and checked.

This system may also require battery to be connected. Although battery voltage is not hazardously high, the battery can deliver large amounts of current. Exercise extreme caution not to inadvertently contact or have any tool inadvertently contact a battery terminal or exposed wire connected to a battery terminal. NEVER allow a metal object, such as a tool, to contact more than one termination at a time, or to simultaneously contact a termination and a grounded object. Even a momentary short circuit can cause explosion and injury. Remove watches, rings, or other jewelry before connecting battery leads. Make the DC (battery) connections last. Make all other electrical connections without DC input power applied to the system.



DANGER! This product requires Safety Extra-Low Voltage (SELV) Inputs. A SELV input (based on the safety requirements for Information Technology Equipment Standards, such as UL1950, IEC 950) is a secondary circuit which is so designed and protected that under normal and single-fault conditions, the voltage between any two paths of the SELV circuit or circuits and for Class 1 equipment (provided with a protective earthing conductor from the building), between any one such part and the equipment protective earthing terminal does not exceed a safe value (42.4 V peak or 60 Vdc under normal conditions). It is separated from the primary or mains supply by Double (insulation comprising both Basic and Supplementary insulation) or Reinforced insulation (a single insulation system which provides a degree of protection against electric shock equivalent to Double insulation)



DANGER! To minimize voltage potentials inside the bay during installation, connect leads to the bay first, before connecting leads to the external source. This includes making connections to any LMS Input/Output (I/O) circuit card.

Wiring Considerations

For recommended wire sizes, crimp lugs, branch circuit protection, alarm relay contact ratings, and general wiring information and restrictions; refer to System Application Guide SAG582140001. The SAG can be accessed via the CD (Electronic Documentation Package) furnished with your system.

Refer to drawing 031110100 for lug crimping information. Refer to drawings 031110200 and 031110300 for additional lug information. These are located in the Installation Manual.

All wiring and branch circuit protection should follow the current edition of the American National Standards Institute (ANSI) approved National Fire Protection Association's (NFPA) National Electrical Code (NEC), and applicable local codes. For operation in countries where the NEC is not recognized, follow applicable codes. For field wiring, use wires suitable for at least 75°C.

MCA Network Interconnections Between Bays

An MCA Network cable must be installed between all bays comprising the system, as detailed in the following procedure.

It is recommended to place the Primary Power Bay on the far right or far left end of the bay line-up, and to expand the system to the left or right of the Primary Power Bay. This allows simple cable connections between bays, and a consistent MCA Bay numbering scheme. The Primary Power Bay is identified by the MCA as Bay #1. The other bays are numbered consecutively, following the bay-to-bay cabling scheme. Thus, bays are numbered #1-#15 from right to left or from left to right.

The Primary Power Bay may be placed in the middle of the bay line-up, expanding the system to the left and right of the Primary Power Bay. In this configuration, bay-to-bay cabling **MUST** start with the Primary Power Bay, then each Secondary Power Bay and Distribution Bay is daisy-chained into the cabling string. Remember, the Primary Power Bay is identified by the MCA as Bay #1, the other bays are numbered consecutively following the bay-to-bay cabling scheme.

Procedure:



NOTE! Refer to **Figure 11** as this procedure is performed.

1. Open all Distribution Bays' front doors.
2. Connect a furnished MCA Network cable (this is a yellow cable) between each bay as follows.
 - a) Connect one end of the cable to the MCA circuit card installed in the Primary Power Bay. Note that there are two connectors; one if the next bay to be connected is on the left, the other if the next bay is on the right. Note also that the MCA (Primary Power Bay) circuit card **MUST NOT** have both of its RJ45 jacks occupied.
 - b) Route the cable through the opening provided in the side of the bay into the next bay.
 - c) Connect the other end of the cable to the Router circuit card installed in the Secondary Power Bay or Distribution Bay. In a Distribution Bay, install the supplied ferrite cable clamp onto the cable near the connector on the router circuit card.
 - d) Daisy-chain all Secondary Power Bays and Distribution Bays together in this fashion. The total length of the network interconnecting the bays cannot exceed 125 feet. Note that if there are bays on both the right and left of the Primary Power Bay, once all bays on one side are connected, you have to take a cable from the last bay connected on that side to a bay on the other side of the bay line-up. It doesn't matter which connector you use on a Secondary Power Bay and Distribution Bay, or which order you connect Secondary Power Bays and Distribution Bays. Just remember, **DO NOT** use both connectors on the Primary Power Bay.
3. If no other connections are required within the bays, close all Distribution Bays' front doors.

Figure 11: MCA Network Bay-Bay Interconnections

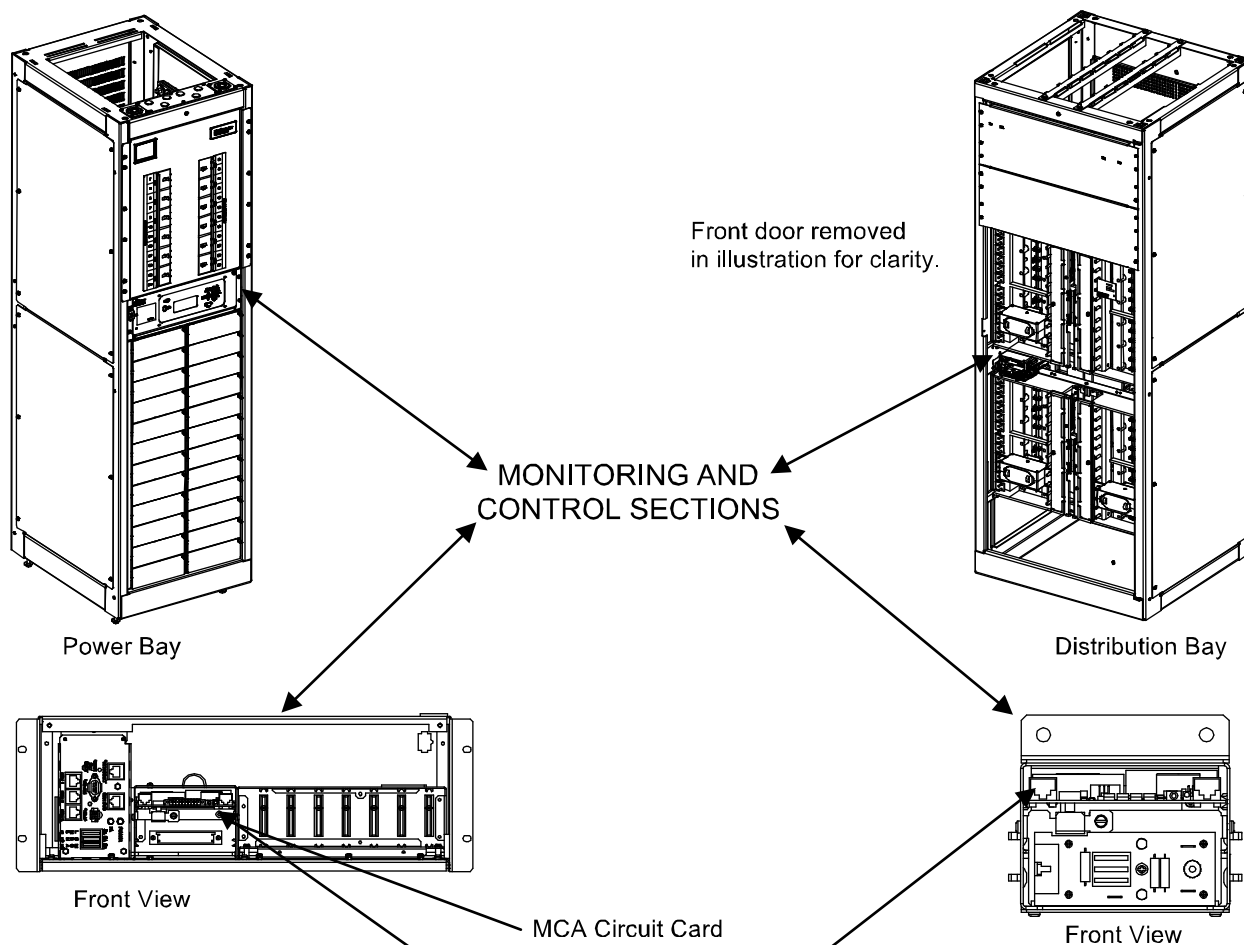

MCA Circuit Card
(Primary Power Bay)
or
Router Circuit Card
(Secondary Power Bays
and Distribution Bays*)

* In a Distribution Bay, install the supplied ferrite cable clamp onto the cable near the router circuit card.
Emerson P/N 242941100
FairRite P/N 0443164251
Steward P/N 28A20025-0A0

**DO NOT USE BOTH
RJ-45 CONNECTORS
IN THE PRIMARY BAY**

MCA Circuit Card P/N 509478
(Primary Power Bay)

Router Circuit Card P/N 509509
(Secondary Power Bays
and Distribution Bays)

Router Circuit Card P/N 509509
(Secondary Power Bays
and Distribution Bays)

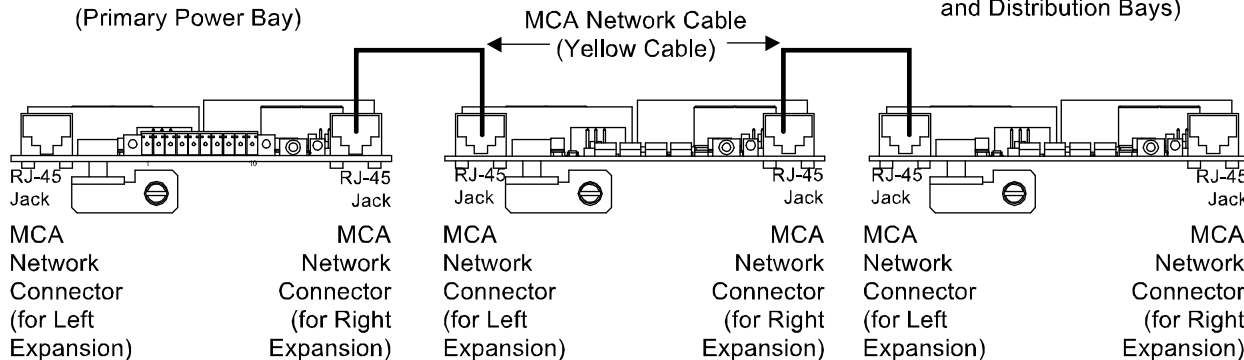

Distribution Bay BAT RTN Connection to System Monitoring and Control Section

Procedure:

1. Connect BAT RTN to the terminal indicated in **Figure 12**. Use 18-16 AWG wire for this connection.

MCA Battery Charge Digital Temperature Compensation Probe Connection

NOTE! The LMS has a Power System Remote Temperature Compensation feature. Refer to the LMS Installation Manual (Section 5879) for programming information.

Mounting Procedure:

1. If furnished, mount the MCA Battery Charge Digital Temperature Compensation Probe to any suitable surface located near the battery. One 1/4-inch hole is provided to mount the probe.

Connection Procedure:

1. If furnished, connect the MCA Battery Charge Digital Temperature Compensation Probe to the connector labeled TEMP located in the Primary Power Bay. Refer to **Figure 13** for location.

MCA CAN Bus Port Connection

Factory connected within the Power Bay.

Figure 12: BAT RTN Connection to Distribution Bay System Monitoring and Control Section

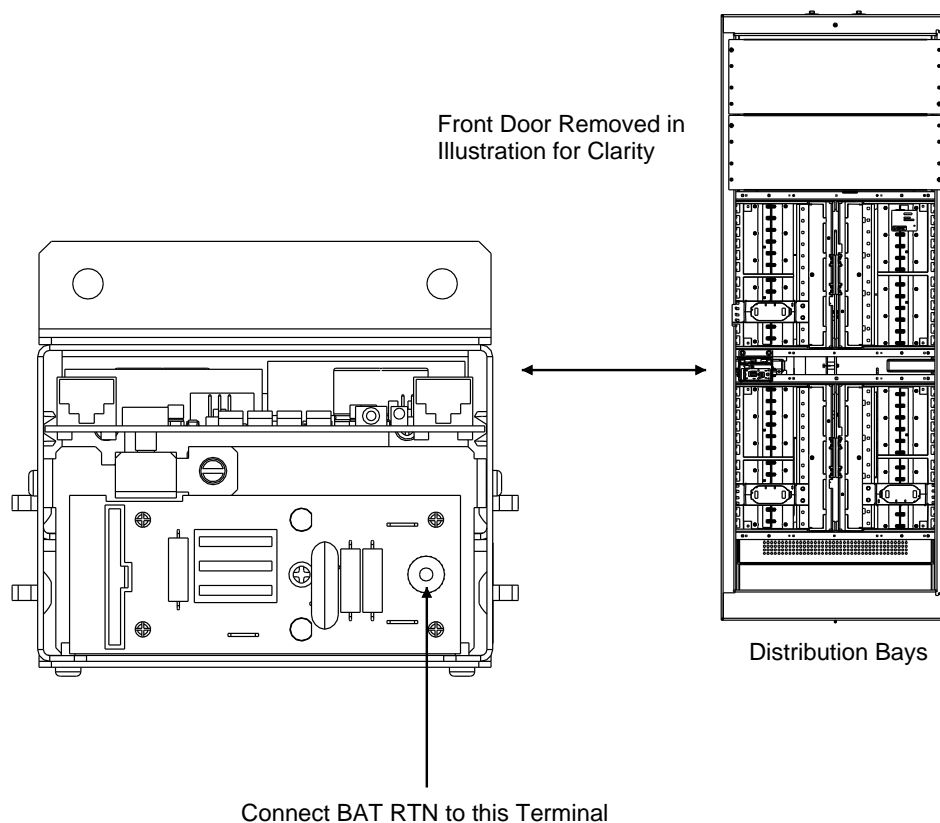
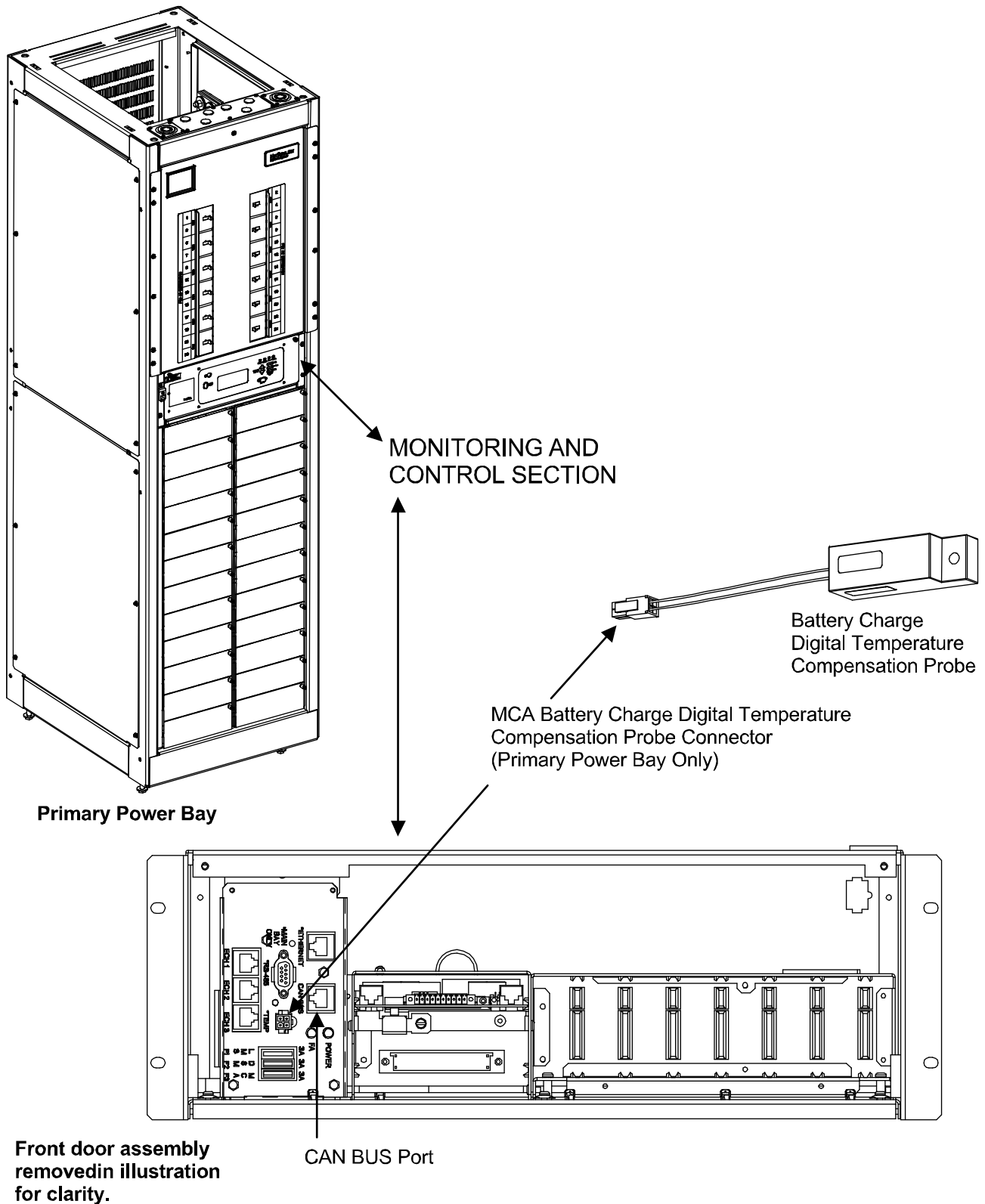

Figure 13: MCA TEMP Connector and MCA CAN Bus Port Location



MCA External Alarm, Reference, and Control Connections and MCA I/O Circuit Card Connections

 **NOTE!** For recommended wire size and alarm relay contact ratings, refer to System Application Guide SAG582140001. The SAG can be accessed via the CD (Electronic Documentation Package) furnished with your system.

Refer to **Figure 14** for connector locations and pinouts.

Connections to Terminal Block TB1 on MCA Circuit Card P/N 509478

MCA circuit card P/N 509478 is located inside the Primary Power Bay. Refer to **Figure 14** for location and connector TB1 pinouts. Terminal block TB1 on MCA circuit card P/N 509478 consists of two pieces snapped together. The two pieces can be separated by first loosening the two screws; then gently pulling the one half from the other. This feature facilitates circuit card wiring and circuit card replacement, if required.

Wires are connected to the terminals of TB1 by inserting the stripped wire into the wire opening, and then tightening the screw. The wires should be checked for proper installation by gently attempting to pull the wires from the terminal. The terminal block accepts a wire size in the range of 28 to 16 AWG. Recommended torque is 2.0 in lbs.

Procedure:

1. **External Voltage Input (for MCA Alarms and Meter Reading):** Leads can be extended from the MCA to an external voltage source. This is the voltage source the MCA monitors for system alarms and displays as "System Output Voltage". If leads are not connected, the MCA automatically senses voltage internally.



ALERT! Equipment damage may result if leads are connected to the wrong terminals of TB1.

If desired, extend leads from the battery or other external voltage point to terminals 1 (negative) and 2 (positive) of TB1. The negative lead should be fused at 1 1/3 amperes.

2. **Remote Test/Equalize:** Customer-furnished loop closure applied between terminals 3 and 4 of TB1 places all Rectifier Modules in all bays comprising the power system in the test/equalize mode of operation. Removal of the signal places all Rectifier Modules in the float mode of operation.
3. **Remote High Voltage Shutdown:** Customer-furnished loop closure applied between terminals 5 and 6 of TB1 activates the high voltage shutdown circuit on all Rectifier Modules in all bays comprising the power system.

 **NOTE!** This feature is to be used only when the system is connected to battery. If the system is operating in a battery-less application, the rectifiers restart since the controller loses DC power. If the Remote HVSD loop closure is still present, rectifiers inhibit again and the process repeats.

4. **Test Input:** The Remote High Voltage Shutdown and/or Rectifier Module Emergency Shutdown (ESTOP) circuits can be tested without affecting the system by applying a Test loop closure between terminals 7 and 8 of TB1 before applying the Remote High Voltage Shutdown or Rectifier Module Emergency Shutdown loop closure signal. Removal of the Test loop closure signal enables normal operation of the Remote High Voltage Shutdown and/or Rectifier Module Emergency Shutdown circuits.

Test Procedure:

- a) Navigate to the "VERIFY TEST, ESTOP,& HVS INPUTS" MCA menu item.

- b) Apply the Test loop closure. Verify MCA displays TEST SHUTDOWN INPUT IS ON.
 - c) With the Test loop closure still applied, apply the Emergency Stop loop closure. Verify MCA displays EMERGENCY STOP INPUT IS ON. Release the Emergency Stop loop closure.
 - d) With the Test loop closure still applied, apply the High Voltage Shutdown loop closure. Verify MCA displays HI VOLTAGE SHUTDOWN INPUT IS ON. Release the High Voltage Shutdown loop closure.
 - e) Release the Test loop closure.
5. **Rectifier Module Emergency Shutdown and Fire Alarm Disconnect (ESTOP):** Customer-furnished loop closure applied between terminals 9 and 10 of TB1 inhibits all Rectifier Modules in all bays comprising the power system. Manual restart is required.



NOTE! *This feature is to be used only when the system is connected to battery. If the system is still connected to an AC source and operating in a battery-less application or is connected to a battery disconnect(s) that is/are also disconnected with an Emergency Power-off signal, then the rectifiers restart since the controller loses DC power. If the Emergency Shutdown and Fire Alarm Disconnect loop closure is still present, the rectifiers inhibit again and the process repeats.*

Connections to MCA Customer Alarm Relay Circuit Cards

MCA Customer Alarm Relay circuit cards can be installed in any of the seven card cage positions in each Power Bay. Each circuit card contains six (6) relays and associated Form-C relay contacts. Each relay on each card can be programmed via the MCA to energize or deenergize when an "MCA Relay Function Channel" alarms. "MCA Relay Function Channels" are programmed via the MCA to alarm for a multitude of conditions. Refer to the Installing the Rectifier Modules and Initially Starting the Power System section for programming information.

Refer to Figure 14 and Table 1 if you are using the default MCA Relay Function Channel configurations and the default MCA Customer Alarm Relay assignments. Refer to blank Table 2 if you want to document a custom configuration.

Connections are made to terminal block TB1 located on the circuit card. Refer to **Figure 14** for location and connector TB1 pinouts. Terminal block TB1 consists of two separate terminal blocks that snap into a common housing. The two terminal blocks can be removed from the common housing by first loosening the two screws on each; then gently pulling the terminal block from the common housing. This feature facilitates circuit card wiring and circuit card replacement, if required.

Wires are connected to the terminals by inserting the stripped wire into the wire opening, and then tightening the screw. The wires should be checked for proper installation by gently attempting to pull the wires from the terminal. The terminal block accepts a wire size in the range of 28 to 16 AWG. Recommended torque is 2.0 in lbs. Note that one of the terminal blocks needs to be removed to gain access to the wire clamping screws of the other.

Connections to MCA I/O Circuit Cards

MCA I/O circuit cards can be installed in any of the seven card cage positions in each Power Bay. These circuit cards offer a variety of analog inputs and outputs, and binary inputs. Refer to the *Installing the Rectifier Modules and Initially Starting the Power System* section for programming information.



NOTE! *Use of the MCA's 'Alternate Current Limit' feature requires an MCA I/O circuit card be installed.*

Connections are made to terminal block TB1 located on the circuit card. Refer to **Figure 14** for location and connector TB1 pinouts. Terminal block TB1 consists of two halves that snap together. The two halves can be separated by first loosening the two screws; then gently pulling halves apart. This feature facilitates circuit card wiring and circuit card replacement, if required.

Wires are connected to the terminals by inserting the stripped wire into the wire opening, and then tightening the screw. The wires should be checked for proper installation by gently attempting to pull the wires from the terminal. The terminal block accepts a wire size in the range of 28 to 16 AWG. Recommended torque is 2.0 in lbs.

To minimize voltage potentials inside the bay during installation, leads should be connected at the bay first, and then connected to the monitored source.

Analog Input

A 0-50 mv input may be provided. Only connect a 50 mv shunt to this input. Recommended wire size is 20-22 gauge, twisted pair wire. Observe correct polarity. Each of the two leads should be protected using a 49.9 Ω fusible resistor. The protection devices should be located as near as possible to the voltage source to provide maximum protection.

Recommended Maximum Analog Input Loop Lengths:

Shunt Inputs: maximum 2,000 ft. loop length.

These maximum distances are derived from calculations which would yield a typical 0.1% of full scale error at the maximum loop length (using 22 gauge twisted hook-up wire). Loop length is the sum of the lengths of the positive and negative leads.

 **NOTE!** Program the respective analog input to show up in the DISTRIBUTION LOAD MENUS or in separate AUXILIARY LOAD MENUS.

Program the scale factor for the shunt connected to this analog input.

Refer to the "INSTALLING THE RECTIFIER MODULES AND INITIALLY STARTING THE POWER SYSTEM" section for programming information.

Analog Output

A 0-50 mv output may be provided. Connect this output to a metering device for remote plant output current monitoring. Recommended wire size is 20-22 gauge, twisted pair wire. Observe correct polarity. Each of the two leads should be protected using a 49.9 Ω fusible resistor. The protection devices should be located as near as possible to the voltage source to provide maximum protection.

 **NOTE!** Program the scale factor for the analog output as outlined in the "INSTALLING THE RECTIFIER MODULES AND INITIALLY STARTING THE POWER SYSTEM" section.

Binary Inputs

Connect binary inputs as required. Recommended wire size is 20-22 gauge, twisted pair wire. A 49.9 Ω fusible resistor, located in each input lead, may be used to protect leads from unintentional shorts during installation or service. These resistors should be located as near as possible to the voltage source to provide maximum protection.



NOTE! Program the respective binary inputs to alarm in the 'open' or 'close' state as outlined in the "INSTALLING THE RECTIFIER MODULES AND INITIALLY STARTING THE POWER SYSTEM" section.

If a binary input alarms, the MCA displays a "Binary Input Customer Text Message" in the I/O Board Alarm Detail Message. If you wish to change the default message, refer to the "SYSTEM OPERATING PROCEDURES" section in Section 6017.

Figure 14: MCA External Alarm, Reference, and Control Connections and MCA I/O Circuit Card Connections
(cont'd on next page)

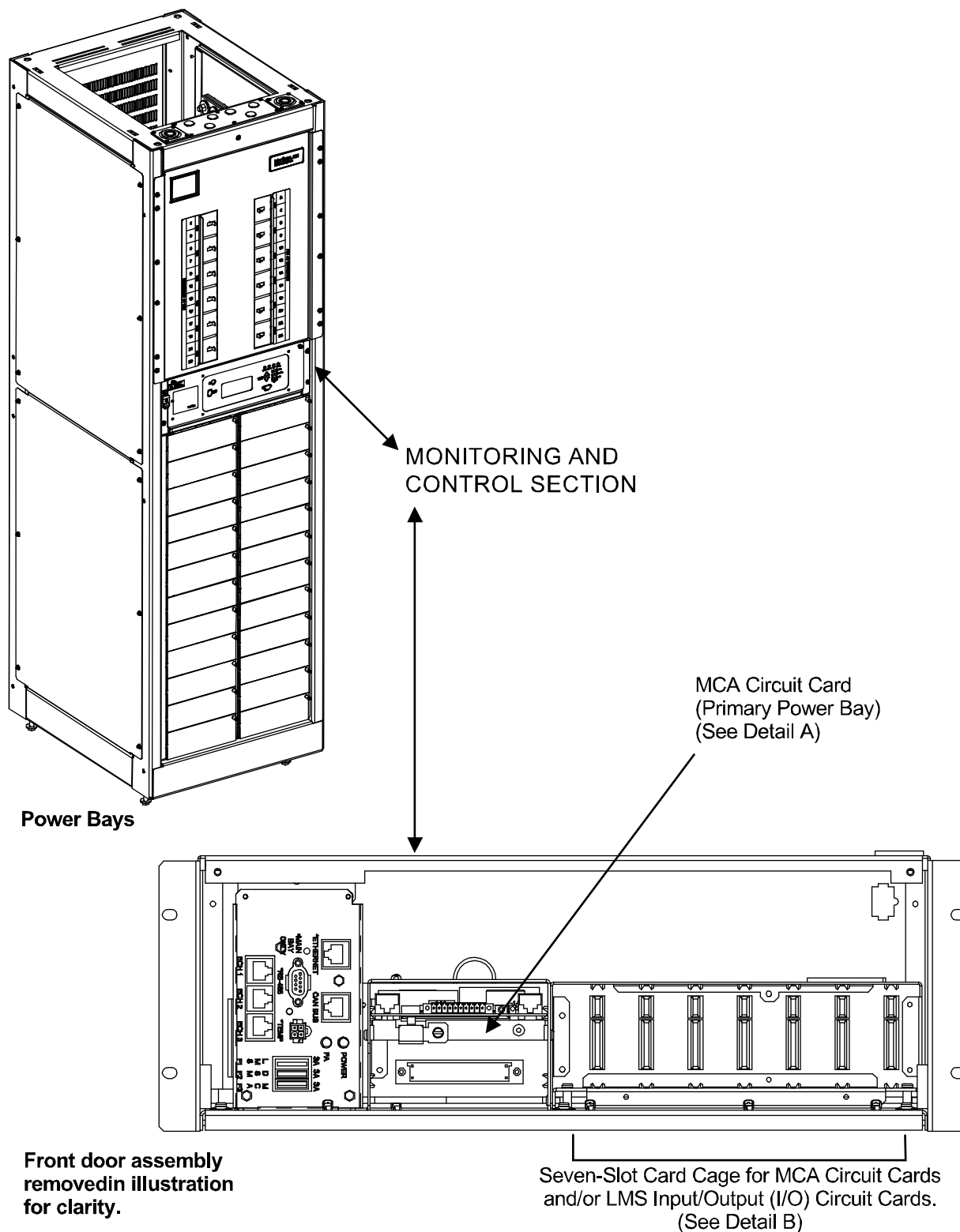

Figure 14: MCA External Alarm, Reference, and Control Connections (cont'd from previous page, cont'd on next page)

* Automatic internal sense when not connected.
 Note: If connected and removed, external A/D Volt Alarm activates. Clear alarm by updating inventory.

** Apply Test contact closure, then apply HVS or ESTOP closure to test these circuits. See MCA display to verify circuits operational.

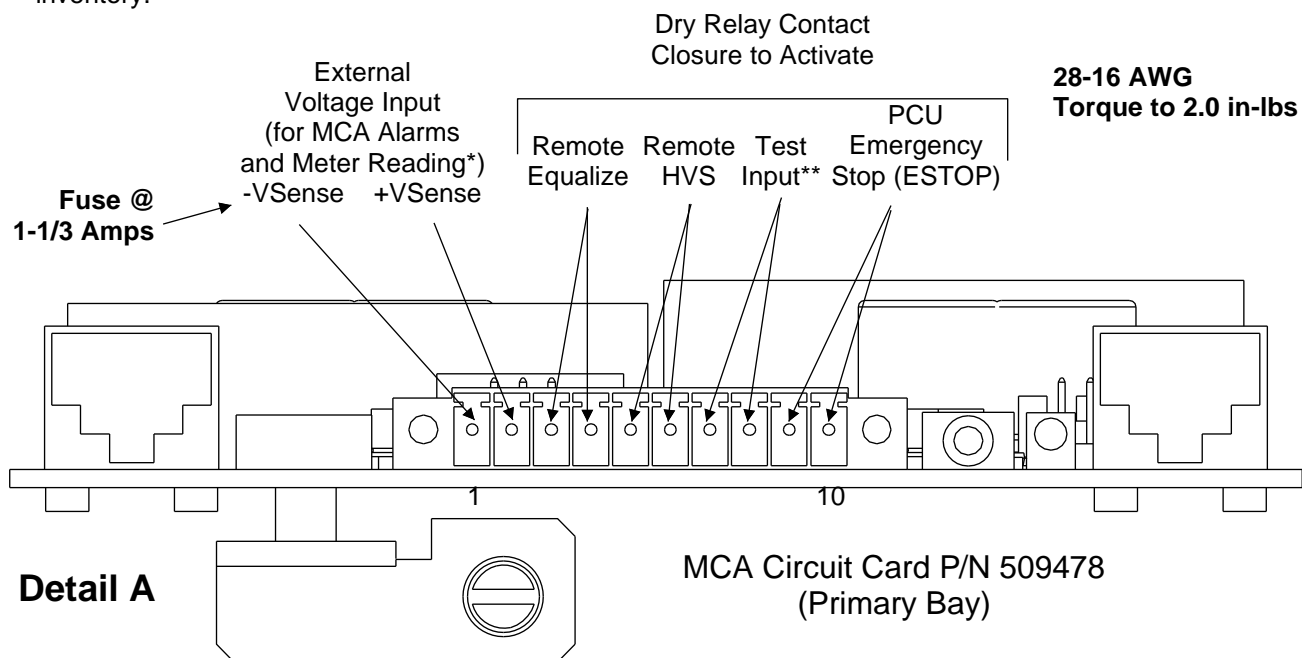
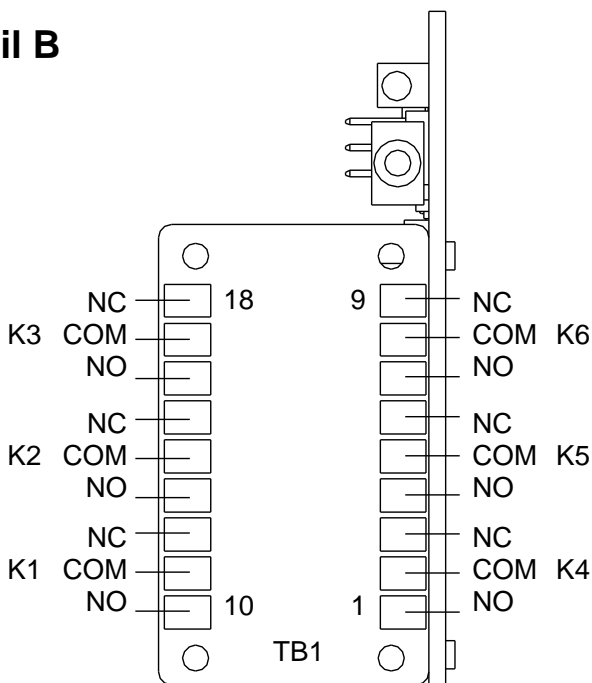

Figure 14: MCA External Alarm, Reference, and Control Connections (cont'd from previous page)

Detail B



**MCA Customer Alarm
Relay Circuit Card P/N 514348
(Primary and/or Secondary Bays)**

**28-16 AWG
Torque to 2.0 in-lbs**

Notes

- NC = Normally Closed
- COM = Common
- NO = Normally Open

All relay contacts are shown with the relay deenergized.

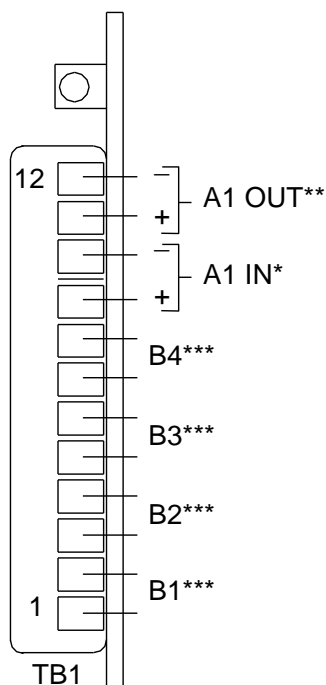

**MCA I/O Circuit Cards
(Primary and/or Secondary Bays)
(P/N 524550, 1 analog input, 1 analog output, 4 binary inputs)
(P/N 524551, 0 analog input, 0 analog output, 4 binary inputs)**

**28-16 AWG
Torque to 2.0 in-lbs**

- * 0-50 mv DC Shunt Input
- ** 0-50 mv DC Output for Remote Plant Output Current Monitoring
- *** Dry Contacts, Circuit Closure to Activate Alarm

Figure 15: Default MCA Customer Alarm Relay Assignments

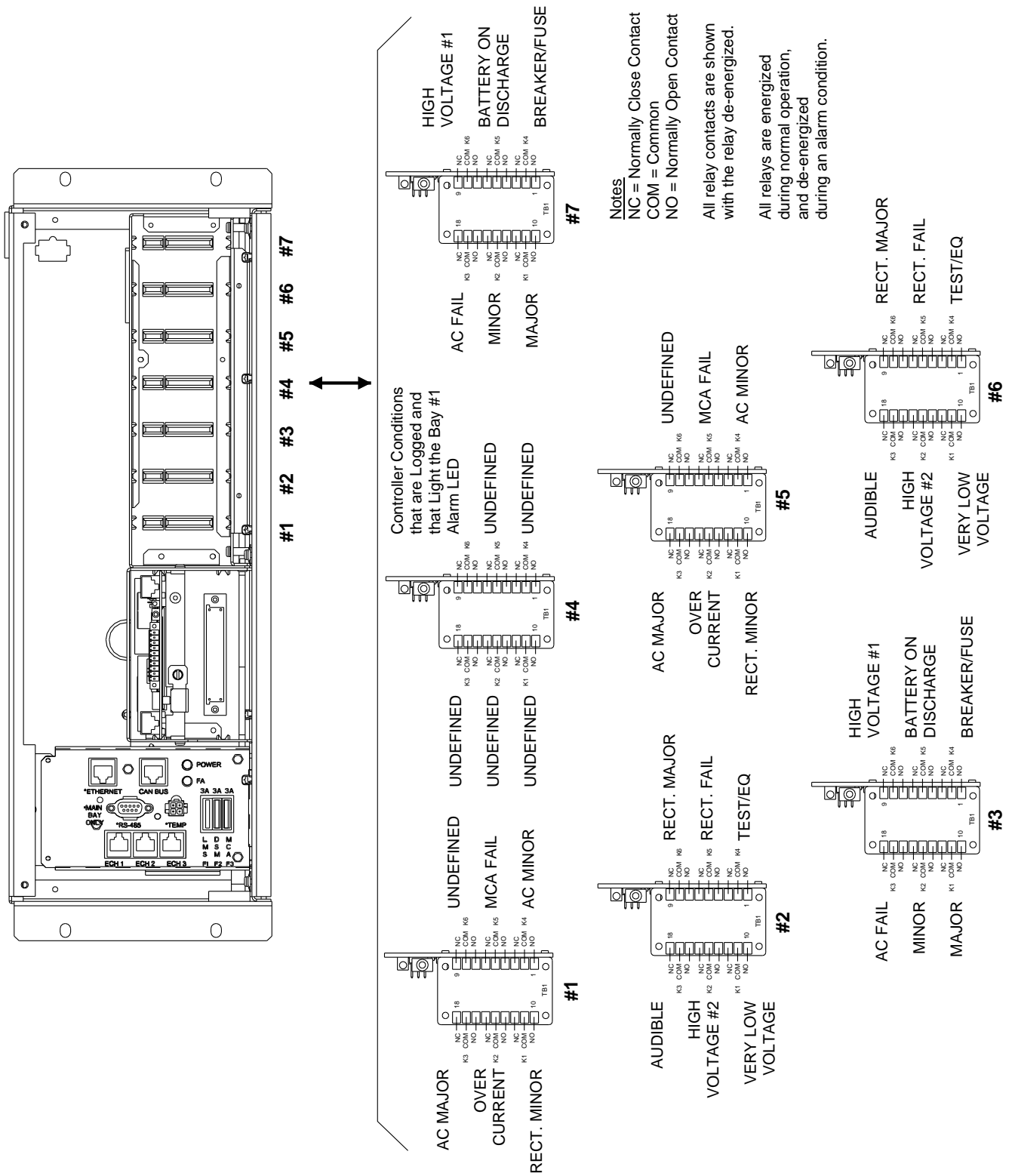

Table 1: Default MCA Relay Function Channel Configurations and Default MCA Customer Alarm Relay Assignments (cont'd on next page)

MCA Relay Function Channel #	Alarm Name	Alarm Configuration	Assigned to Relay #...	installed in Slot #... of any Bay
1	Major Alarm	Emergency Stop Input Active, Remote High Voltage Shutdown Input Active, System Voltage is Very Low, System Battery On Discharge, System High Voltage #1 Alarm, System High Voltage #2 Alarm, 1 System CB/Fuse Alarm, 2+ System CB/Fuse Alarm, 2+ Rectifier Module Failures 'Major' Type, No Rectifier Module in Inventory (installed), 1 Dist. Panel Failure, 2+ Dist. Panels Failures, No Dist. Panel in Inventory (Installed), 1 Router Failure, 2+ Router Failures, No Router in Inventory (installed), 1 Relay Board Failure, 2+ Relay Board Failures, No Relay Board in Inventory (installed), High Temp #1 Alarm, High Temp #2 Alarm, Low Temp #1 Alarm, Low Temp #2 Alarm, Temperature Sensor No Signal, Controller (MCA) Failure, Controller Initializing	1	7 and 3
2	Minor Alarm	1 Rectifier Module Failure 'Major' Type, 1 Rectifier Module Failure 'Minor' Type, 2+ Rectifier Module Failures 'Minor' Type, Monitoring Does Not Respond, Total Distribution Load Alarm, Distribution Group A Load Alarm, Distribution Group B Load Alarm, Display Does Not Respond	2	7 and 3
3	AC Fail Alarm	AC Power Off to 1 Rectifier Module, AC Power Off to 2+ Rectifier Modules, AC Power Off to All Rectifier Modules	3	7 and 3
4	Circuit Breaker / Fuse Alarm	1 System CB/Fuse Alarm, 2+ System CB/Fuse Alarms	4	7 and 3
5	Battery on Discharge Alarm	System Battery on Discharge Alarm	5	7 and 3
6	High Voltage Alarm #1	System High Voltage #1 Alarm	6	7 and 3
7	Very Low Voltage Alarm	System Voltage is Very Low	1	6 and 2
8	High Voltage Alarm #2	System High Voltage #2 Alarm	2	6 and 2
9	Audible Alarm Contacts	See Relay Function Channel 25	3	6 and 2

Table 1: Default MCA Relay Function Channel Configurations and Default MCA Customer Alarm Relay Assignments (cont'd from previous page, cont'd on next page)

MCA Relay Function Channel #	Alarm Name	Alarm Configuration	Assigned to Relay #...	installed in Slot #... of any Bay
10	Test / Equalize Indication	Test/Equalize Mode is Active	4	6 and 2
11	Rectifier Fail Alarm	1 Rectifier Module Failure Any Type, 2+ Rectifier Module Failures Any Type, No Rectifier Module in Inventory (installed)	5	6 and 2
12	Rectifier Major Alarm	2+ Rectifier Module Failures 'Major' Type, No Rectifier Module in Inventory (installed)	6	6 and 2
13	Rectifier Minor Alarm	1 Rectifier Module Failure 'Minor' Type, 2+ Rectifier Module Failures 'Minor' Type, 1 Rectifier Module Failure 'Major' Type	1	5 and 1
14	Over Current Alarm	Total Distribution Load Alarm, Distribution Group A Load Alarm, Distribution Group B Load Alarm	2	5 and 1
15	AC Major Alarm	AC Power is Off to All Rectifier Modules, AC Power is Off to 2+ Rectifier Modules	3	5 and 1
16	AC Minor Alarm	AC Power is Off to 1 Rectifier Module	4	5 and 1
17	MCA Fail Alarm	Controller (MCA) Failure, Controller Initializing	5	5 and 1
18	Undefined	--	6	5 and 1
19	Undefined	--	1	4
20	Undefined	--	2	4
21	Undefined	--	3	4
22	Undefined	--	4	4
23	Undefined	--	5	4

Table 1: Default MCA Relay Function Channel Configurations and Default MCA Customer Alarm Relay Assignments (cont'd from previous page)

MCA Relay Function Channel #	Alarm Name	Alarm Configuration	Assigned to Relay #...	installed in Slot #... of any Bay
24	<p>Defines the MCA Alarm conditions. These conditions are reported in the Alarm Log as 'Controller Alarms', and activate the Primary Power Bay Alarm LED.</p>	<p>Emergency Stop Input Active, Remote High Voltage Shutdown Input Active, System Voltage is Very Low, System Battery On Discharge, System High Voltage #1 Alarm, System High Voltage #2 Alarm, No Rectifier Module in Inventory (installed), No Dist. Panel in Inventory (Installed), No Router in Inventory (installed), No Relay Board in Inventory (installed), High Temp #1 Alarm, High Temp #2 Alarm, Low Temp #1 Alarm, Low Temp #2 Alarm, Temperature Sensor No Signal, Controller (MCA) Failure, Controller Initializing, Total Distribution Load Alarm, Distribution Group A Load Alarm, Distribution Group B Load Alarm, Monitoring Does Not Respond, Display Does Not Respond, All LMS LED Channels</p>	6	4
25	<p>Defines which conditions show up in the MCA Main Alarm Menu (and scroll on Line 1 of the MCA Display). These conditions also activate the Audible Alarm.</p>	<p>Emergency Stop Input Active, Remote High Voltage Shutdown Input Active, System Voltage is Very Low, System Battery On Discharge, System High Voltage #1 Alarm, System High Voltage #2 Alarm, 1 System CB/Fuse Alarm, 2+ System CB/Fuse Alarm, 1 Rectifier Module Failure 'any' Type, 2+ Rectifier Module Failures 'any' Type, No Rectifier Module in Inventory (installed), 1 Dist. Panel Failure, 2+ Dist. Panels Failures, No Dist. Panel in Inventory (Installed), 1 Router Failure, 2+ Router Failures, No Router in Inventory (installed), 1 Relay Board Failure, 2+ Relay Board Failures, No Relay Board in Inventory (installed), High Temp #1 Alarm, High Temp #2 Alarm, Low Temp #1 Alarm, Low Temp #2 Alarm, Temperature Sensor No Signal, Controller (MCA) Failure, Controller Initializing, Total Distribution Load Alarm, Distribution Group A Load Alarm, Distribution Group B Load Alarm, Monitoring Does Not Respond, Display Does Not Respond, All LMS LED Channels, All Rectifier Module's AC Fail</p>	--	--

Table 2: Custom MCA Relay Function Channel Configurations and Custom MCA Customer Alarm Relay Assignments

MCA Relay Function Channel #	Alarm Name	Alarm Configuration	Assigned to Relay #...	installed in Slot #... of Bay #...
1				
2				
3				
4				
5				
6				
7				
8				
9				
10				
11				
12				
13				
14				
15				
16				
17				
18				
19				
20				
21				
22				
23				
24	Defines the MCA Alarm conditions. These conditions are reported in the Alarm Log as 'Controller Alarms', and activate the Primary Power/ Distribution Bay Alarm LED.			
25	Defines which conditions show up in the MCA Main Alarm Menu (and scroll on Line 1 of the MCA Display). These conditions also activate the Audible Alarm.		--	--

LMS Connections (if LMS Furnished)

Refer to **Figure 16** for connector locations.

If the LMS is furnished, make the following connections as required. Refer to the separate LMS Installation Instructions (Section 5879) for procedures. Section 5879 can be accessed from the CD (Electronic Documentation Package) furnished with your system.

- a) LMS CPU/Hardware Fail Alarm
- b) LMS Local Port
- c) LMS Ethernet Port
- d) LMS Modem Port
- e) LMS OEM (RS-485) Port
- f) LMS Input/Output (I/O) Circuit Cards
- g) LMS Energy Management Connections
(when used w/ 'traditional' rectifiers external to the system)
- h) LMS Sequential Start Connections
- i) Optional LMS Expansion Cabinet(s) and Expansion Assembly(s) Connections to Customer Equipment

Procedures are provided next in this document for *LMS Network Interconnections between Bays and Optional LMS Expansion Cabinet(s) and Expansion Assembly(s)*.

Figure 16: LMS Connection Points (cont'd on next page)

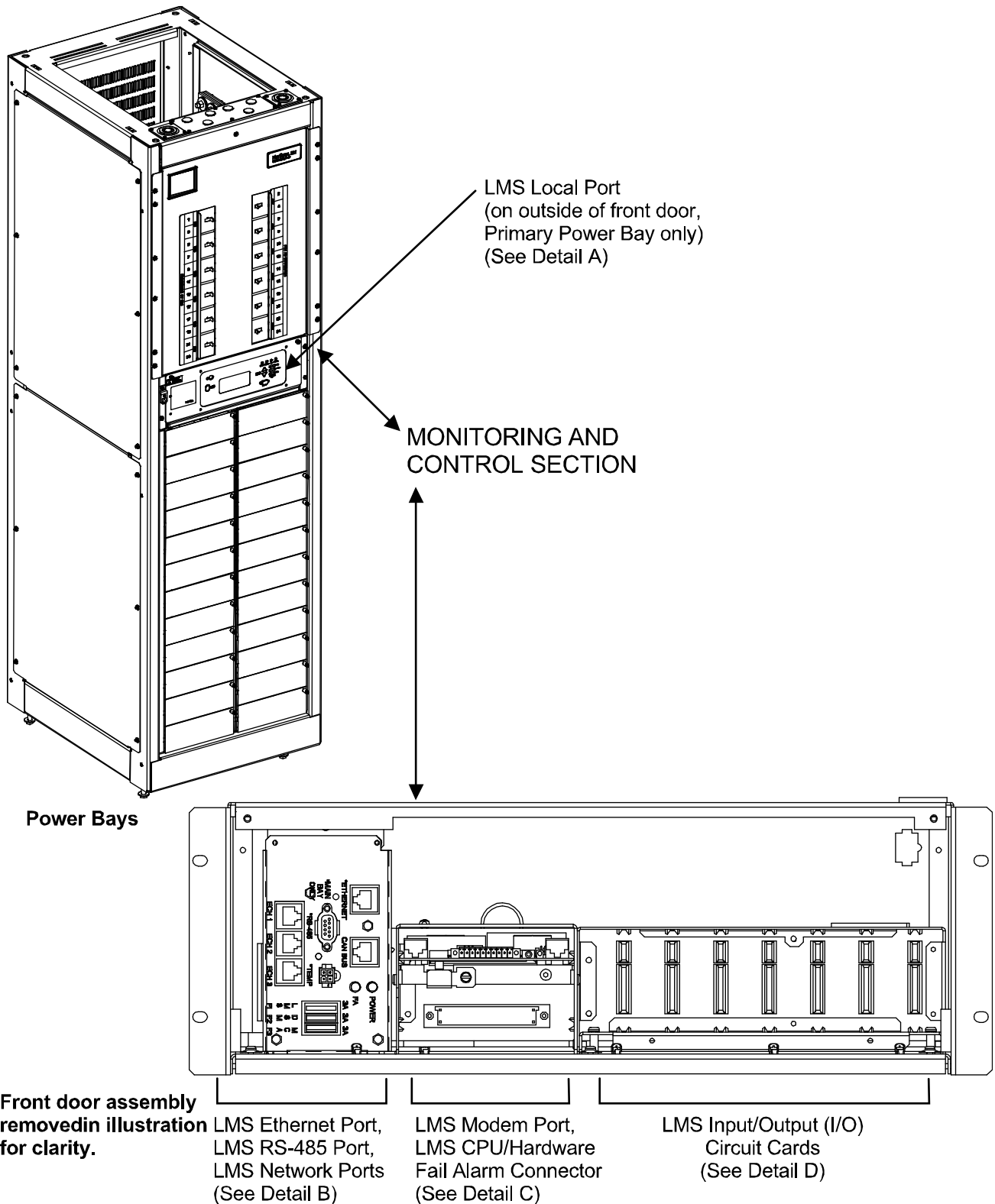
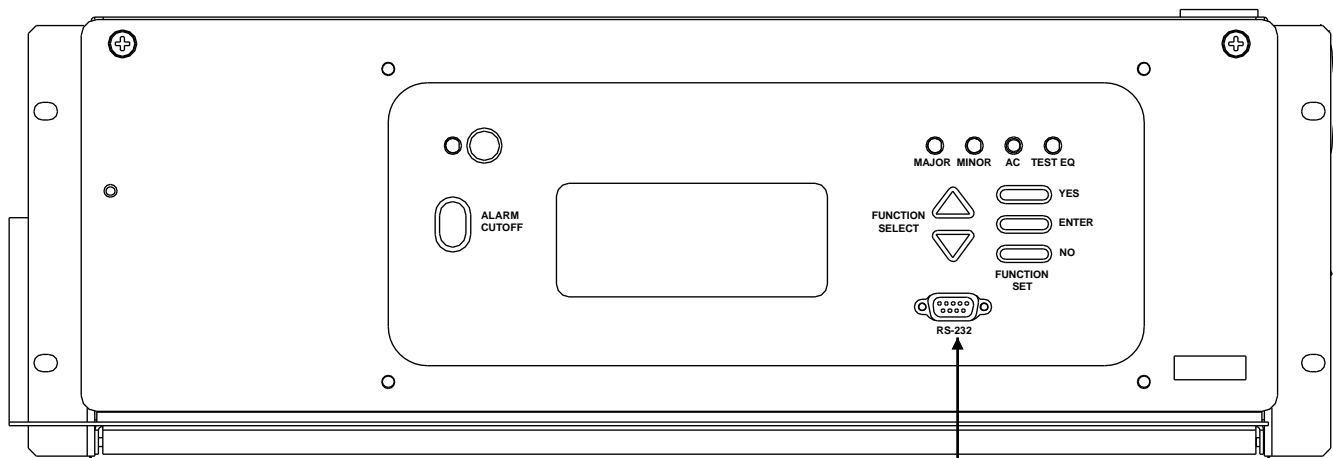

Figure 16: LMS Connection Points (cont'd from previous page, cont'd on next page)

Detail A

MCA CONTROL PANEL AND DISPLAY

(Primary Power Bay Monitoring and Control Section)



LMS LOCAL PORT
(RS-232)
(active only if
optional LMS installed)

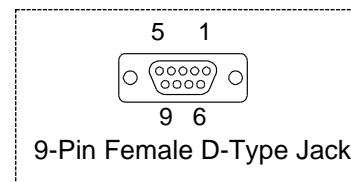

Figure 16: LMS Connection Points (cont'd from previous page, cont'd on next page)

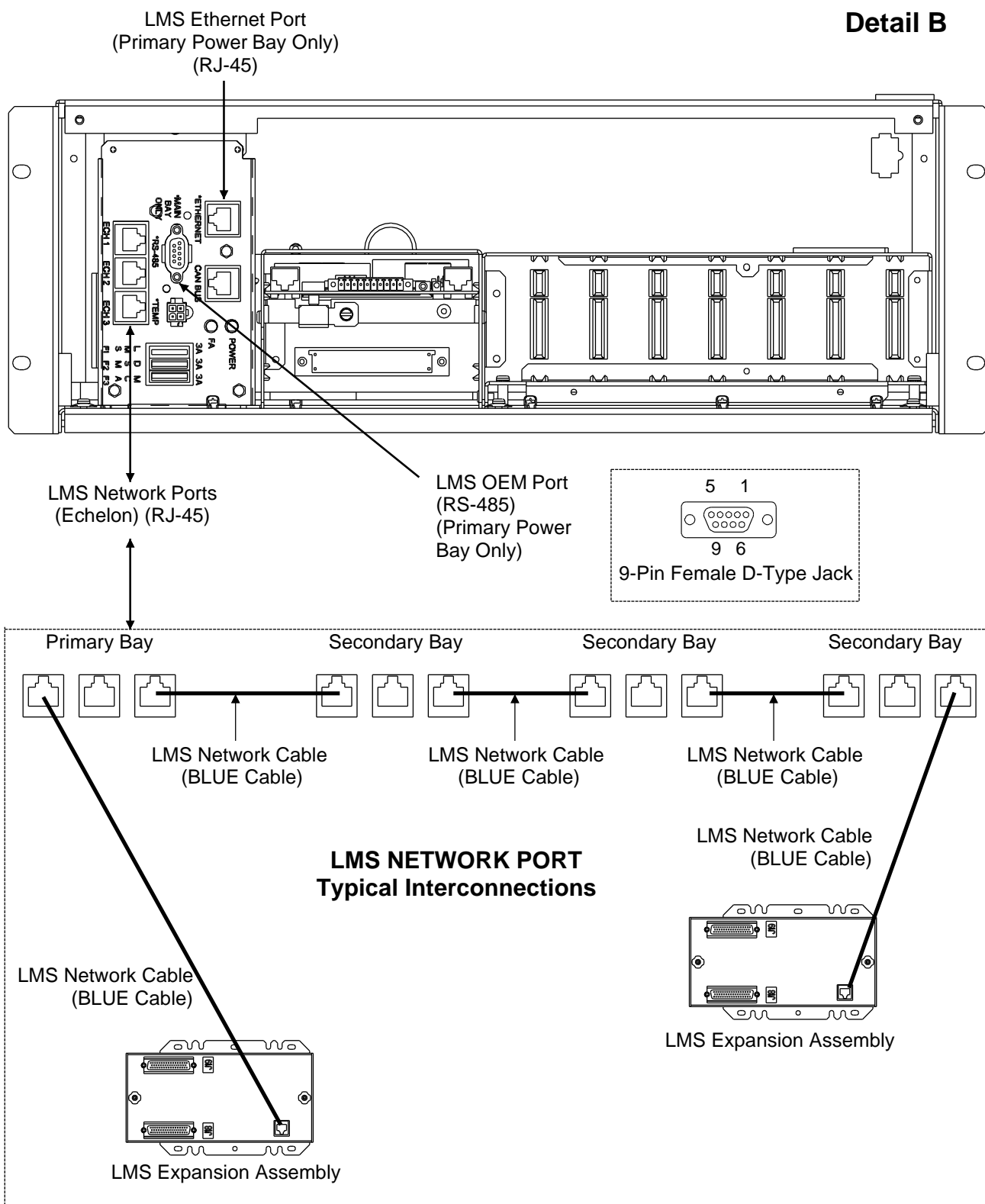

Figure 16: LMS Connection Points (cont'd from previous page, cont'd on next page)

Detail C

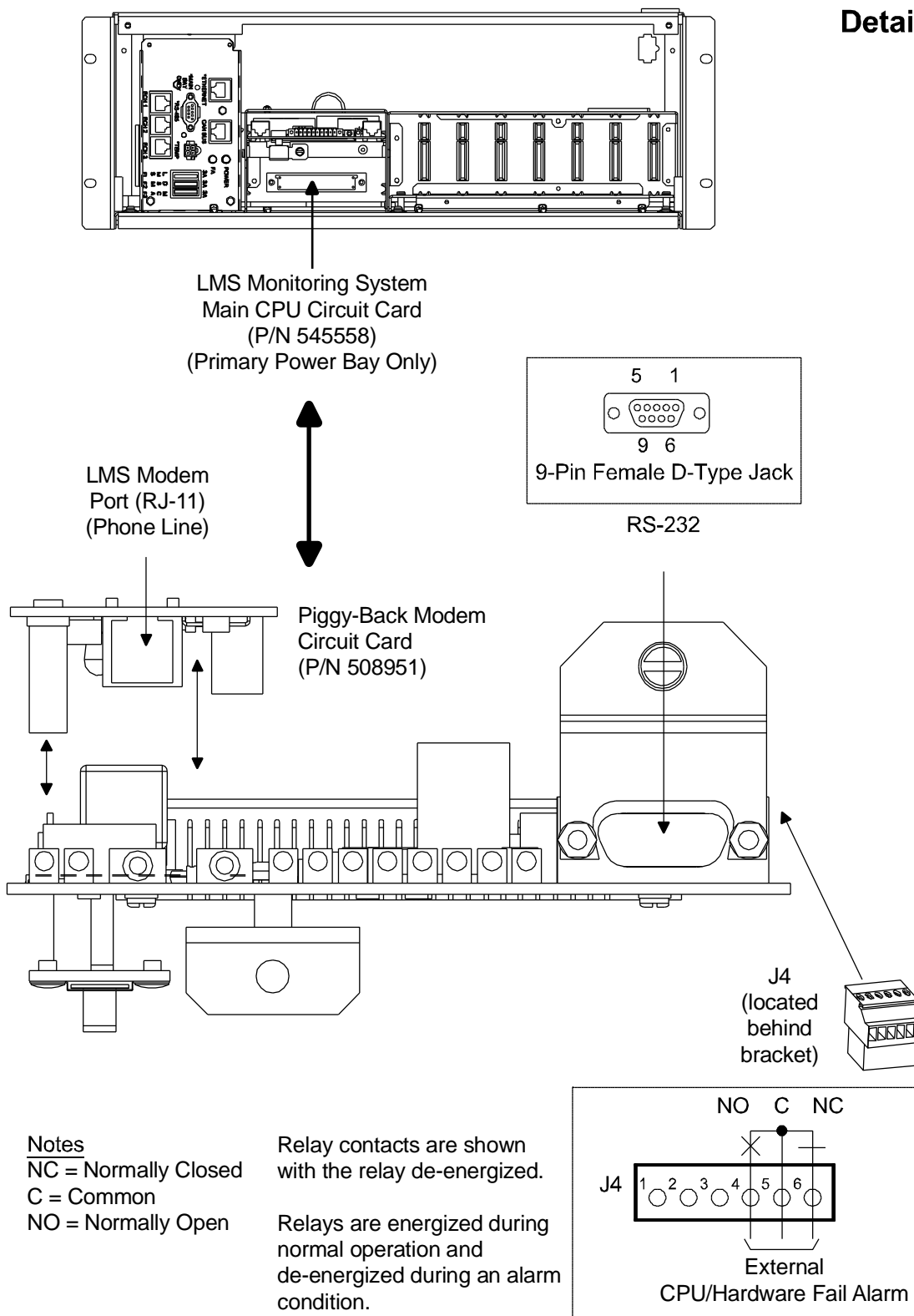
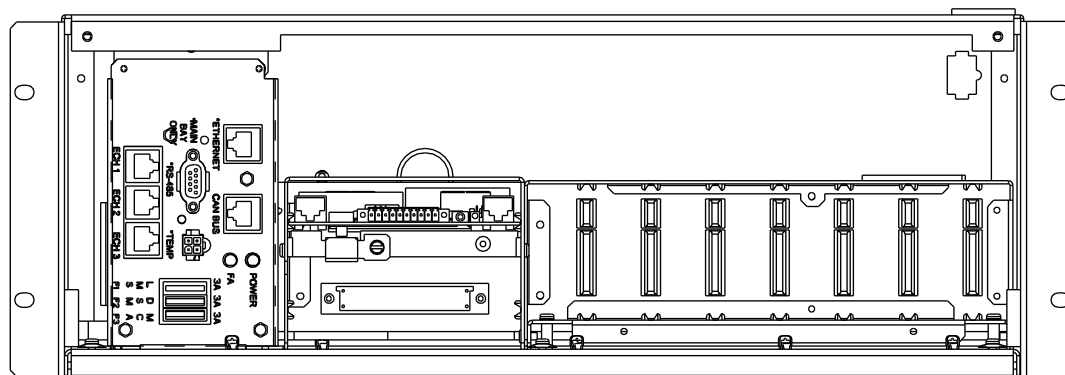

Figure 16: LMS Connection Points (cont'd from previous page)

Detail D



Seven-Slot Card Cage for MCA
Customer Alarm Relay Circuit Cards
and/or LMS Input/Output (I/O) Circuit Cards



Available LMS I/O Circuit Cards

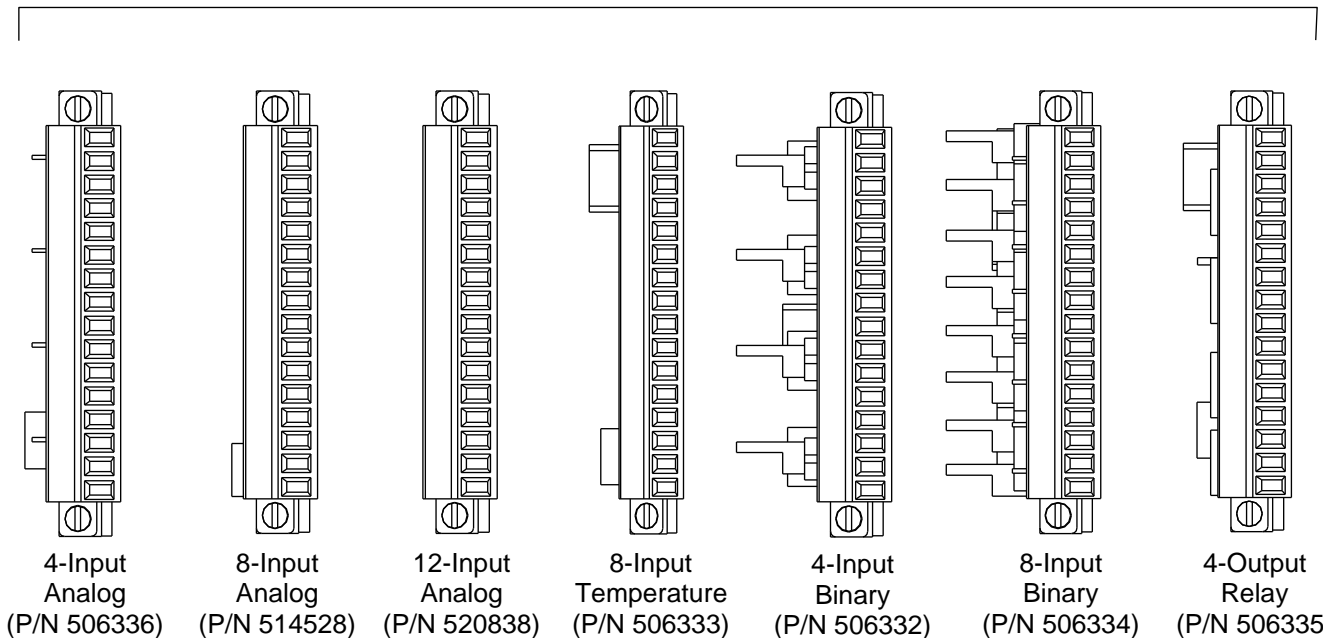

LMS Network Interconnections between Bays and Optional LMS Expansion Assembly(s)

Between Bays

An LMS Network cable must be installed between all bays with LMS CPU circuit cards installed, as detailed in the following procedure. Pre-assembled cables are available. Refer to System Application Guide SAG582140001 for P/N's. The SAG can be accessed via the CD (Electronic Documentation Package) furnished with your system. Refer to "LMS Network Cable Assembly Instructions" in this section to assemble your own cable.

Procedure:



NOTE! Refer to **Figure 16** as this procedure is performed.

1. Connect a furnished LMS Network cable (this is a blue cable) between bays containing LMS CPU circuit cards. There are three (3) LMS Network ports located in each bay. Any of these ports can be used in a multitude of configurations to interconnect the bays. Refer to **Figure 16** for typical interconnections. Refer to System Application Guide SAG586505000 for maximum combined cable length restrictions. The SAG can be accessed via the CD (Electronic Documentation Package) furnished with your system.
 - a) Connect one end of the cable to an LMS Network Port in the first bay. Note that there are three connectors, use any open connector.
 - b) Route the cable through the opening provided in the side of the bay into the next bay.
 - c) Connect the other end of the cable to an LMS Network Port in the second bay. Note that there are three connectors, use any open connector.
2. Connect all bays containing LMS CPU circuit cards together in this fashion.

To Optional LMS Expansion Cabinet(s) and Expansion Assembly(s)

Any optional LMS Expansion Cabinet and/or Expansion Assembly(s) must be interconnected into the LMS Network, as detailed in the following procedure. Pre-assembled cables are available. Refer to System Application Guide SAG582140001 for P/N's. The SAG can be accessed via the CD (Electronic Documentation Package) furnished with your system. Refer to "LMS Network Cable Assembly Instructions" in this section to assemble your own cable.

Procedure:



NOTE! Refer to **Figure 16** as this procedure is performed.

1. Connect a furnished LMS Network cable (this is a blue cable) between a bay containing an LMS CPU circuit card and the optional LMS Expansion Cabinet and/or Expansion Assembly. There are three (3) LMS Network ports located in each bay. Any of these ports can be used in a multitude of configurations to interconnect the optional LMS Expansion Cabinet and Expansion Assembly. Refer to **Figure 16** for typical interconnections. Refer to System Application Guide SAG586505000 for maximum combined cable length restrictions. The SAG can be accessed via the CD (Electronic Documentation Package) furnished with your system.
 - a) Connect one end of the cable to an LMS Network Port in a bay containing an LMS CPU circuit card. Note that there are three connectors, use any open connector.
 - b) Connect the other end of the cable to the optional LMS Expansion Cabinet or Assembly.

2. Connect all optional LMS Expansion Cabinets and Expansion Assemblies into the LMS Network in this fashion.

LMS Network Cable Assembly Instructions

Specifications:

A multi-conductor cable that is terminated on both ends with an RJ-45 plug. These plugs mate with RJ-45 jacks provided throughout the LMS network.

A cable with RJ 45 plugs attached to both ends may be supplied, or a length of cable with two unconnected RJ 45 plugs may be supplied, as ordered. If required, the installer is to assemble the cable per these specifications and per site requirements.

The recommended cable is a category 5, four twisted pair conductor, 24 gauge solid copper cable. Vertiv Part No. 156202100. Belden Part No. 1585AD15. If this cable is ordered through Vertiv, specify the required length in 5 foot increments.

The required components necessary to terminate the cable are provided in a kit offered by Vertiv. The Vertiv Part No. of this kit is 483589500 and consist of:

- a) Two (2) RJ-45 plugs. Vertiv Part No. 247803300. AMP Part No. 557315.

Assembly:

Attach a plug to each end of the cable per **Table 3**, and the following instructions:

1. Trim and strip (0.5 – 0.56 inch) jacketed cable using appropriate, commercially available tools.

 **NOTE!** Do not strip insulated wires.

1. Insert the wires completely into the RJ-45 plug. Visually inspect the assembly to ensure proper routing of the individual conductors. If using the recommended cable, follow the color scheme shown in **Table 3**. Refer to **Figure 17** for the pin numbering scheme of the RJ-45 plug.
2. Terminate the cable using appropriate crimp tool, AMP Part No. 2-231652-1 with die set AMP Part No. 853400-1.

Table 3: LMS Network Cable Wire Color Scheme

PIN NO.	WIRE COLOR
1	White / Blue Stripe
2	Blue
3	White / Orange Stripe
4	Orange
5	White / Green Stripe
6	Green
7	White / Brown Stripe
8	Brown

Figure 17: RJ-45 Plug

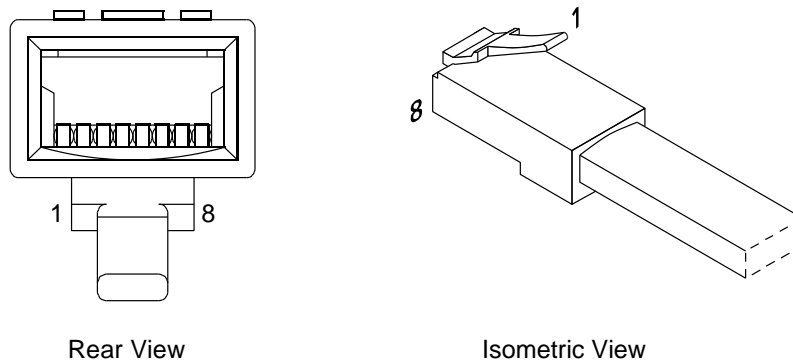

Bay Frame Grounding Connections

NOTE! Refer to System Application Guide SAG58214-0001 for recommended wire size and crimp lug. Refer to drawing 031110100 for lug crimping information. Refer to drawings 031110200 and 031110300 for additional lug information. The SAG and Engineering Drawings can be accessed via the CD (Electronic Documentation Package) furnished with your system. A copy of drawing 031110100 is also located at the end of this manual for your convenience.

For bay grounding requirements; refer to the National Electrical Code, applicable local codes, and your specific site requirements.

Procedure

Located on the top of each bay are four sets of 1/4" clearance holes on 5/8" centers. Attach customer grounding network leads to these using customer supplied two-hole lugs, mounting bolts, and hardware. Recommended torque is 60 in-lbs when using 1/4 inch hardware and a Belleville lock washer.

Refer to **Figure 18** and **Figure 19** for location.

Figure 18: Power Bay Frame Grounding Connection Locations

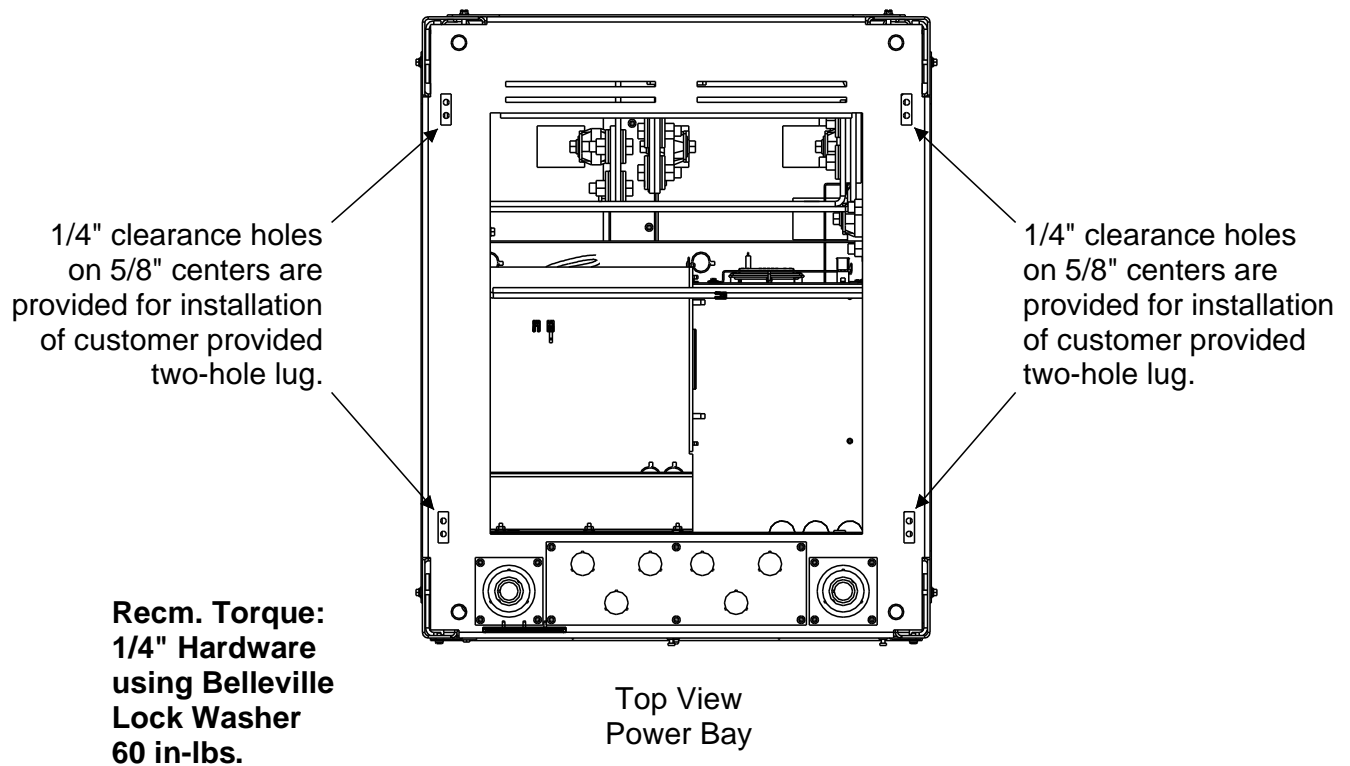
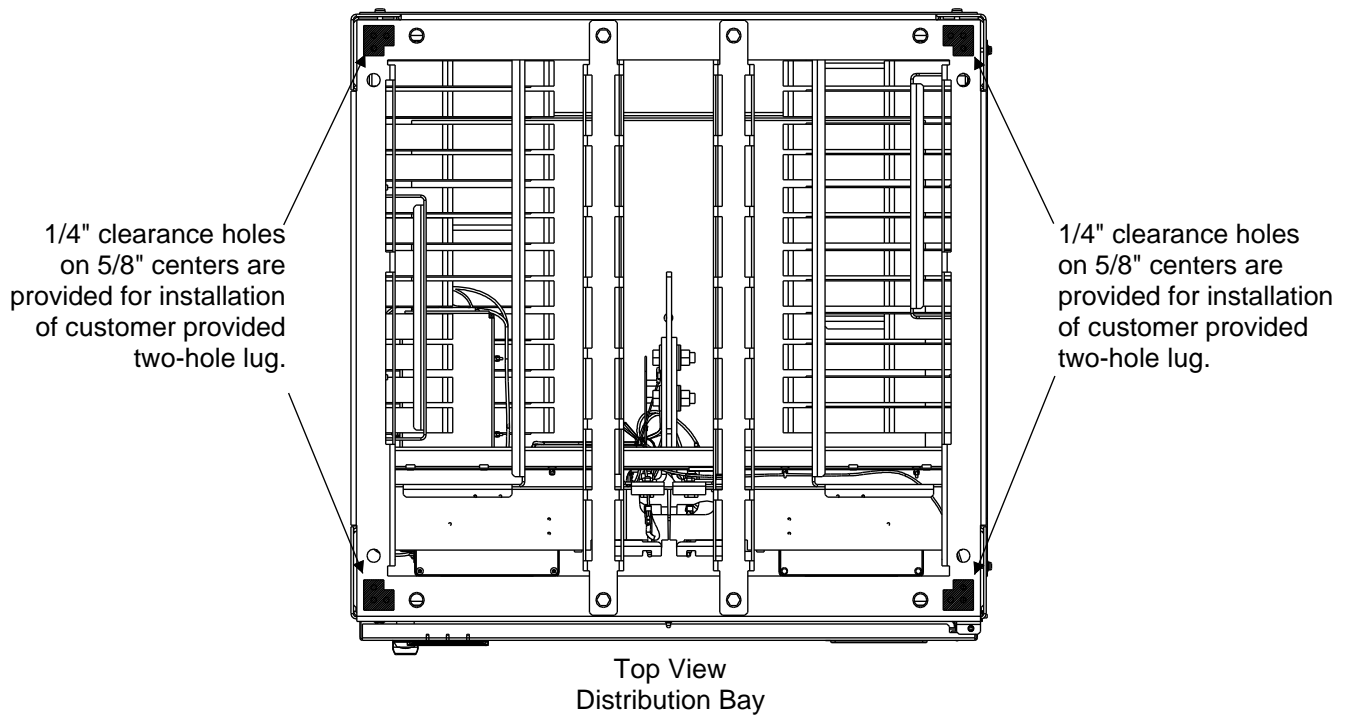



Figure 19: Distribution Bay Frame Grounding Connection Locations



Recm. Torque

**1/4" Hardware
using Belleville
Lock Washer
60 in-lbs.**

Load Connections

 **NOTE!** Refer to System Application Guide SAG582140001 for recommended wire sizes and crimp lugs. Refer also to the SAG for maximum size of wire to connect to the various lug landing points. Refer to drawing 031110100 for lug crimping information. Refer to drawings 031110200 and 031110300 for additional lug information. The SAG and Engineering Drawings can be accessed via the CD (Electronic Documentation Package) furnished with your system. A copy of drawing 031110100 is also located at the end of this manual for your convenience.

To 218 Circuit Breakers and TPL Fuses

Each Distribution Bay has four (4) distribution buses. Each distribution bus has twelve (12) fuse/circuit breaker device mounting positions. Note that the various fuse/circuit breaker devices require different number of mounting positions. The load side of each fuse/circuit breaker mounting position is bused to the rear of the bay. Each fuse/circuit breaker device requires a load lug adapter plate kit that mounts to the appropriate load side busbars at the rear of the bay (except 1-pole devices). Load return leads are terminated outside the bay to the optional external ground busbar mounted on top of the bay.

Refer to **Figure 20** for load lug landing locations.

When lugs are secured using 3/8 inch hardware, recommended torque is 180 in lbs when a Belleville lock washer is used and 300 in lbs when a standard flat washer and lock washer are used.

Load Side

Connect load leads to the respective load busbar located at the rear of the bay. These busbars are provided with 3/8" clearance holes on 1 inch centers for installation of customer provided two hole lugs. Note that for distribution devices that require more than one distribution mounting positions, lug adapter kits are furnished, as ordered. The kit supplied lug adapters are provided with 3/8 clearance holes on 1 inch centers for installation of customer provided two-hole lugs. The kits also contain 3/8" mounting hardware.

Load Return Side

Load return leads are terminated outside the bay to customer provided return busbars.

Figure 20: Load Connections to 218 Circuit Breakers and TPL Fuses

**Connect Load Leads Here
(Load Lug Adapter Plates
May Be Required, Refer to
Previous Illustrations)**

- to Distribution:
Bus #2
Position #13
- to Distribution:
Bus #2
Position #18
- to Distribution:
Bus #2
Position #19
- to Distribution:
Bus #2
Position #24

- to Distribution:
Bus #4
Position #37
- to Distribution:
Bus #4
Position #42
- to Distribution:
Bus #4
Position #43
- to Distribution:
Bus #4
Position #48

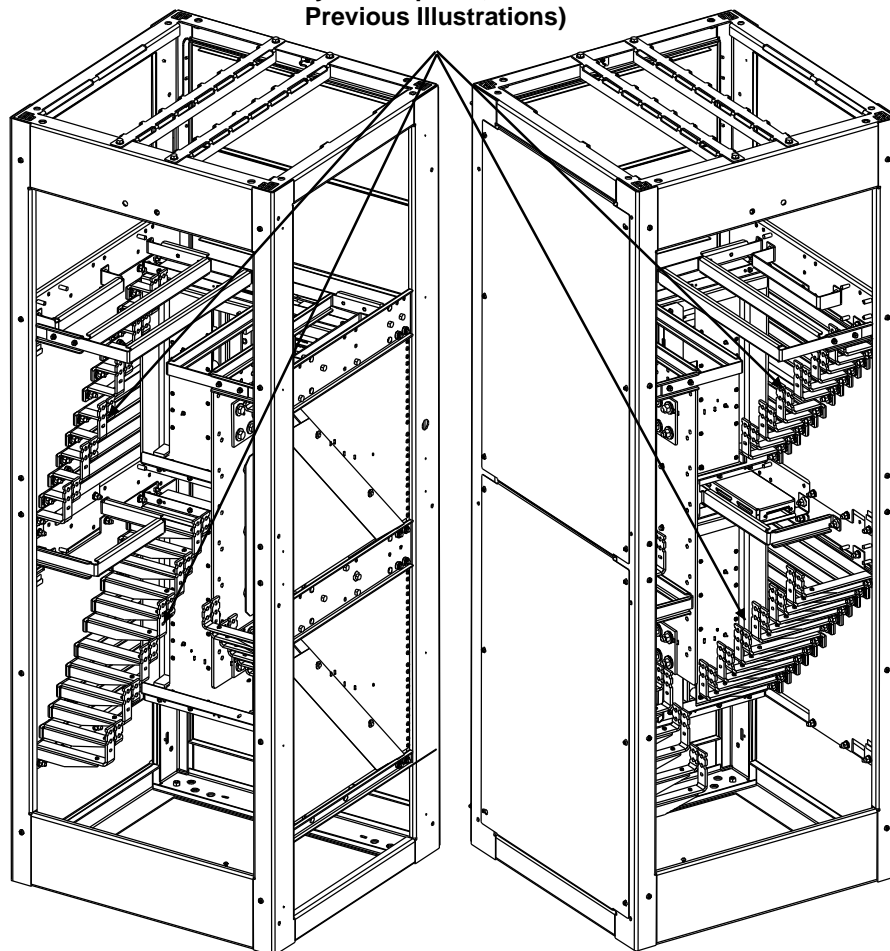

- to Distribution:
Bus #1
Position #12
- to Distribution:
Bus #1
Position #7
- to Distribution:
Bus #1
Position #6
- to Distribution:
Bus #1
Position #1

- to Distribution:
Bus #3
Position #36
- to Distribution:
Bus #3
Position #31
- to Distribution:
Bus #3
Position #30
- to Distribution:
Bus #3
Position #25

Rear View

Rear View

Rear cover panels removed in illustration for clarity.

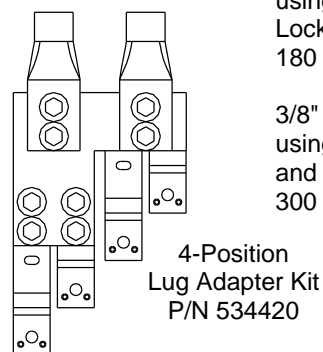
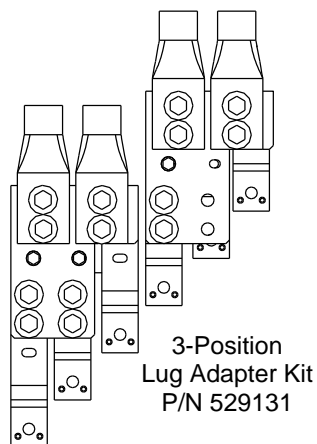
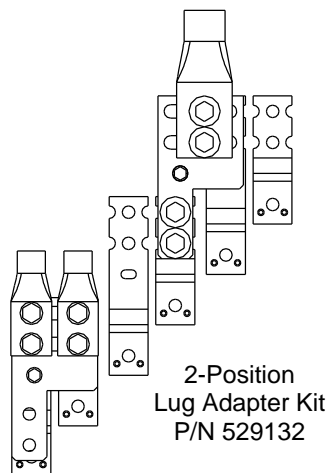

Recm. Torque

3/8" Hardware
using Belleville
Lock Washer,
180 in-lbs

3/8" Hardware
using flat washer
and lock washer,
300 in-lbs

To Optional Bullet Device Panel (TLS/TPS Fuses and Bullet Nose-Type Circuit Breakers)

Refer to **Figure 21** for load lug landing locations.

When lugs are secured using 1/4 inch hardware, recommended torque is 60 in lbs when a Belleville lock washer is used, and 84 in lbs when a standard flat washer and lock washer are used.

Load Side

Connect load leads to the busbars provided on the List C Fuse/Circuit Breaker Panel. These busbars provide 1/4-20 threaded holes on 5/8" centers for installation of customer provided two-hole lugs.

Customer must provide lug mounting bolts and additional hardware.

Bolt length: 3/4".

Load Return Side

Load return leads are terminated outside the bay to customer provided return busbars.

Figure 21: Load Connections to Optional Bullet Device Panel (TLS/TPS Fuses and Bullet Nose-Type Circuit Breakers)

Note: Load leads are connected to load busbars. These busbars provide 1/4-20 threaded holes on 5/8" centers for installation of customer provided two-hole lugs. Customer must provide lug mounting bolts and additional hardware. Bolt length: 3/4".

Recm. Torque

1/4" Hardware using Belleville Lock Washer, 60 in-lbs

1/4" Hardware using flat washer and lock washer, 84 in-lbs

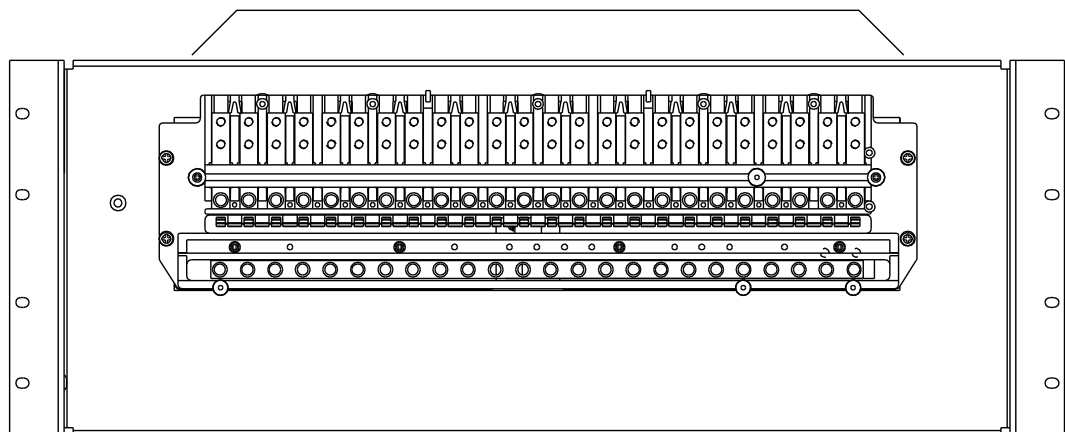

Installing and Wiring an Optional Bullet Nose-Type 10-Position GMT Fuse Module (P/N 509128)

Installing

Each optional Bullet Nose-Type 10-Position GMT Fuse Module plugs into 'distribution device' mounting positions of a List C Fuse/Circuit Breaker Panel. Each GMT Fuse Module requires five (5) bullet device mounting positions. See **Figure 22**.

1. Install the GMT Fuse Module in the desired position oriented as shown in **Figure 22**.
2. Connect a customer provided ground lead from the List C Fuse/Circuit Breaker Panel lug mounting busbar associated to the GMT Fuse Module mounting position (far left or far right most lug mounting position) to the system's ground/return busbar. Recommended wire size is 10 AWG. Refer to **Figure 22**.



NOTE! *The ground lead will be installed in a position normally used for -48V distribution. It is recommended to use a Green lead and insulate the connection with shrink tubing to avoid incidental contact.*

3. Install an appropriately sized GMT-type fuse in each fuse mounting position F1 F10 on the module. If dummy fuses are installed, remove them first.
4. Verify dummy fuses are installed in all unused positions of the GMT Fuse Module.
5. Verify fuse F11 is a Bussmann GMT 18/100 Amp alarm fuse.
6. Verify fuse safety covers are installed over all fuses.

Wiring

Connections are made to the terminal blocks located on the optional Bullet Nose-Type 10-Position GMT Fuse Module as shown in **Figure 22**. Wires are connected to the terminals by inserting the stripped wire into the wire opening, and then tightening the screw. The wires should be checked for proper installation by gently attempting to pull the wires from the terminal. The terminal block accepts a wire size in the range of 24 to 14 AWG. Recommended torque is 5.0 in lbs.

**30A MAXIMUM CAPACITY PER BLOCK.
SEE SAG582140001 FOR ADDITIONAL RESTRICTIONS**

Figure 22: Installing and Wiring an Optional Bullet Nose-Type 10-Position GMT Fuse Module (P/N 509128)

DANGER

Ensure leads are connected to proper polarity for the device installed, either a Distribution Device (load lead connection) or ground/return to GMT Module (ground connection).

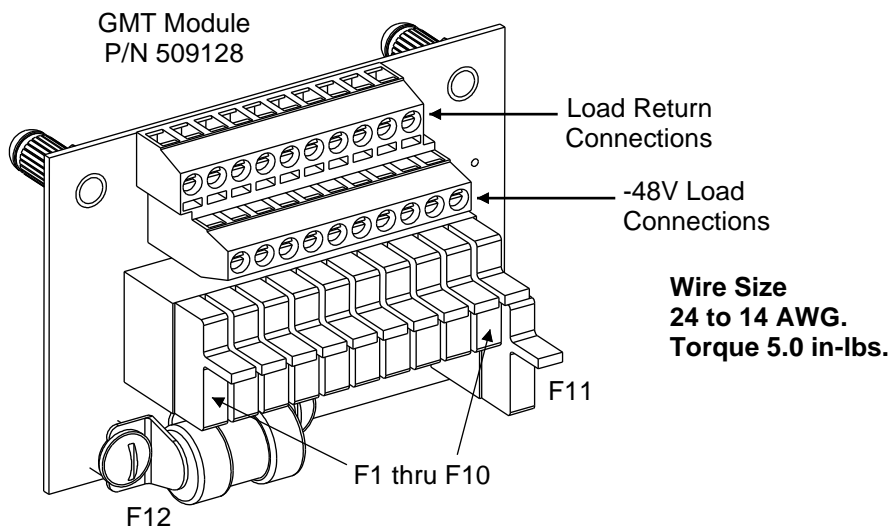
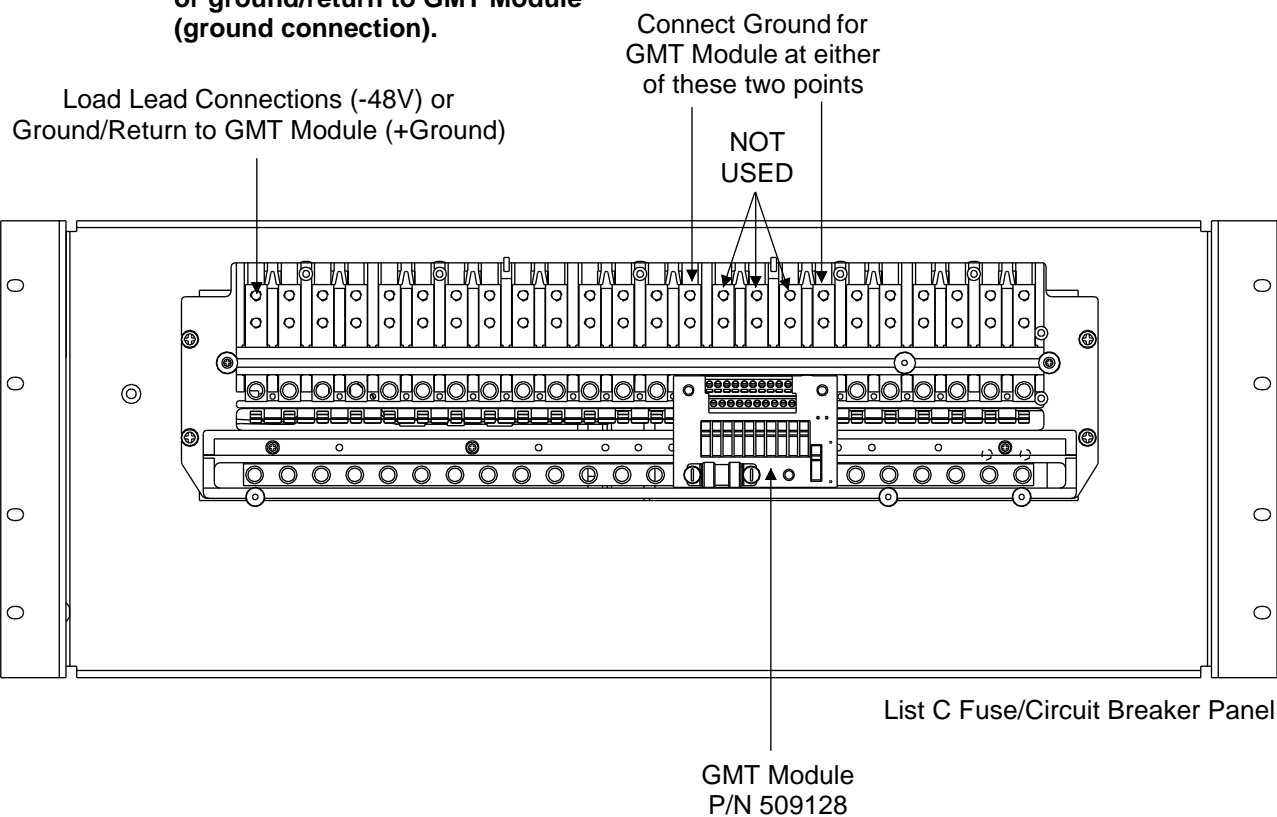

AC Input and AC Input Ground Connections

 **NOTE!** Refer to System Application Guide SAG582140001 for recommended wire size, branch circuit protection, and crimp lugs. Refer also to the SAG for maximum size of wire to connect to the various lug landing points. Refer to drawing 031110100 for lug crimping information. Refer to drawings 031110200 and 031110300 for additional lug information. The SAG and Engineering Drawings can be accessed via the CD (Electronic Documentation Package) furnished with your system.

Wiring Routing Guidelines

Circular openings are provided in the top of each Power Bay for AC input and AC input grounding conductors. Conduit adapter plates are also furnished. Refer to **Figure 23** and **Figure 24** for dimensions. Conduit fittings should be installed, and AC input and AC input grounding conductors should be routed into the cabinet through these openings.

AC Input Connections to Lists 5 and 13 Power Bays (12 or 24 AC Input Feeds)

Lists 5 and 13 Power Bays provide AC input connection points for each of the twenty-four (24) rectifier module mounting positions (24 feeds). A busbar jumper option is provided which ties the AC input of two (2) rectifier module mounting positions together, so each AC input branch circuit feeds two (2) rectifiers (12 feeds). Customer to provide AC input branch circuit protection.

Refer to **Figure 23** for lead landing locations.

Procedure:

1. Remove the front cover panel and clear plastic shield to gain access to the Rectifier Module AC input terminal blocks.
2. If 24 feeds are desired, refer to **Figure 23** and remove the 12-feed busbar jumpers.
3. Connect the AC input leads as shown in **Figure 23**.
4. Connect Phase A to the busbar designated "A". Connect Phase B to the busbar designated "B". Connect Phase C to the busbar designated "C".
5. These busbars are equipped with 10-32 studs on 5/8 inch centers. Attach Rectifier Module AC input leads to these using customer supplied two-hole lugs. When lugs are secured using 10-32 inch hardware recommended torque is 23 in lbs when a standard flat washer and lock washer are used.
6. Equipment grounding conductors must be provided with the AC input conductors supplied to each bay. Connect to earth ground, not power system neutral.
7. Refer to **Figure 23** and locate the Rectifier Module AC input frame ground studs (1/4 20 studs on 1" centers). Attach Rectifier Module AC input ground leads to these studs using customer supplied two-hole lugs and mounting hardware. When lugs are secured using 1/4 inch hardware, recommended torque is 84 in lbs when a standard flat washer and lock washer are used.
8. Replace the front cover panel when done.

Figure 23: AC Input and AC Input Ground Connections (12 or 24 AC Feeds) (Lists 5 and 13 Power Bays)(cont'd on next page)

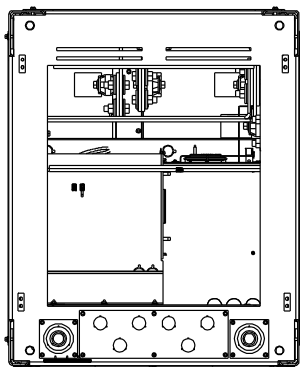

Six (6) 1.125" openings for 3/4" conduit.
 Two (2) conduit plates with 2.5", 1.75", and 1.125" knock-outs for 2", 1.5", and 3/4" conduit.
 Six (6) 1.75" openings for 1.5" conduit (under plate).

Top View
 Power Bay

Note: Rectifier numbering is for wiring identification only. The MCA identifies rectifiers differently.

- Rectifier #1 Mounting Slot
- Rectifier #3 Mounting Slot
- Rectifier #5 Mounting Slot
- Rectifier #7 Mounting Slot
- Rectifier #9 Mounting Slot
- Rectifier #11 Mounting Slot
- Rectifier #13 Mounting Slot
- Rectifier #15 Mounting Slot
- Rectifier #17 Mounting Slot
- Rectifier #19 Mounting Slot
- Rectifier #21 Mounting Slot
- Rectifier #23 Mounting Slot

Front View
 Power Bay

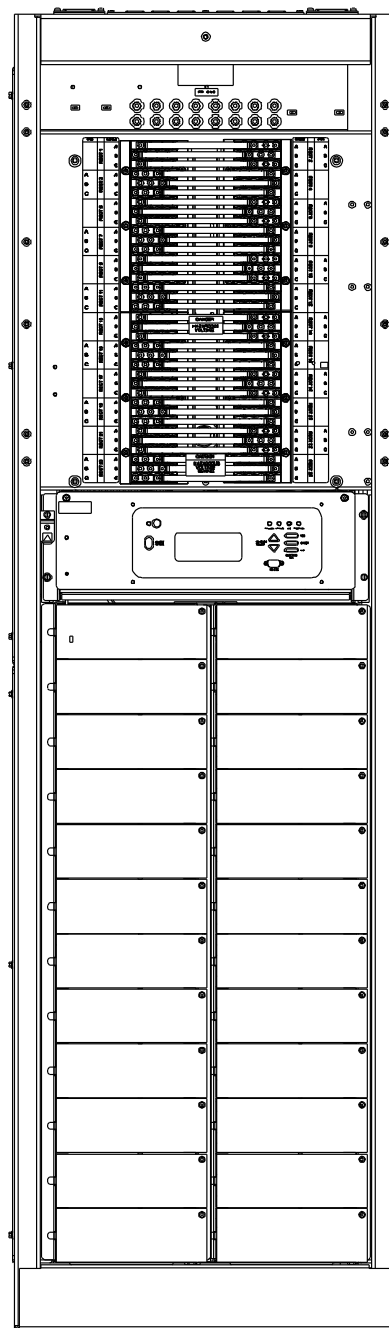

See Detail A
 (12 Feeds)

See Detail B
 (24 Feeds)

Front cover panel
 removed in illustration

- Rectifier #2 Mounting Slot
- Rectifier #4 Mounting Slot
- Rectifier #6 Mounting Slot
- Rectifier #8 Mounting Slot
- Rectifier #10 Mounting Slot
- Rectifier #12 Mounting Slot
- Rectifier #14 Mounting Slot
- Rectifier #16 Mounting Slot
- Rectifier #18 Mounting Slot
- Rectifier #20 Mounting Slot
- Rectifier #22 Mounting Slot
- Rectifier #24 Mounting Slot

Figure 23: AC Input and AC Input Ground Connections (12 or 24 AC Feeds) (Lists 5 and 13 Power Bays)
(cont'd from previous page, cont'd on next page)

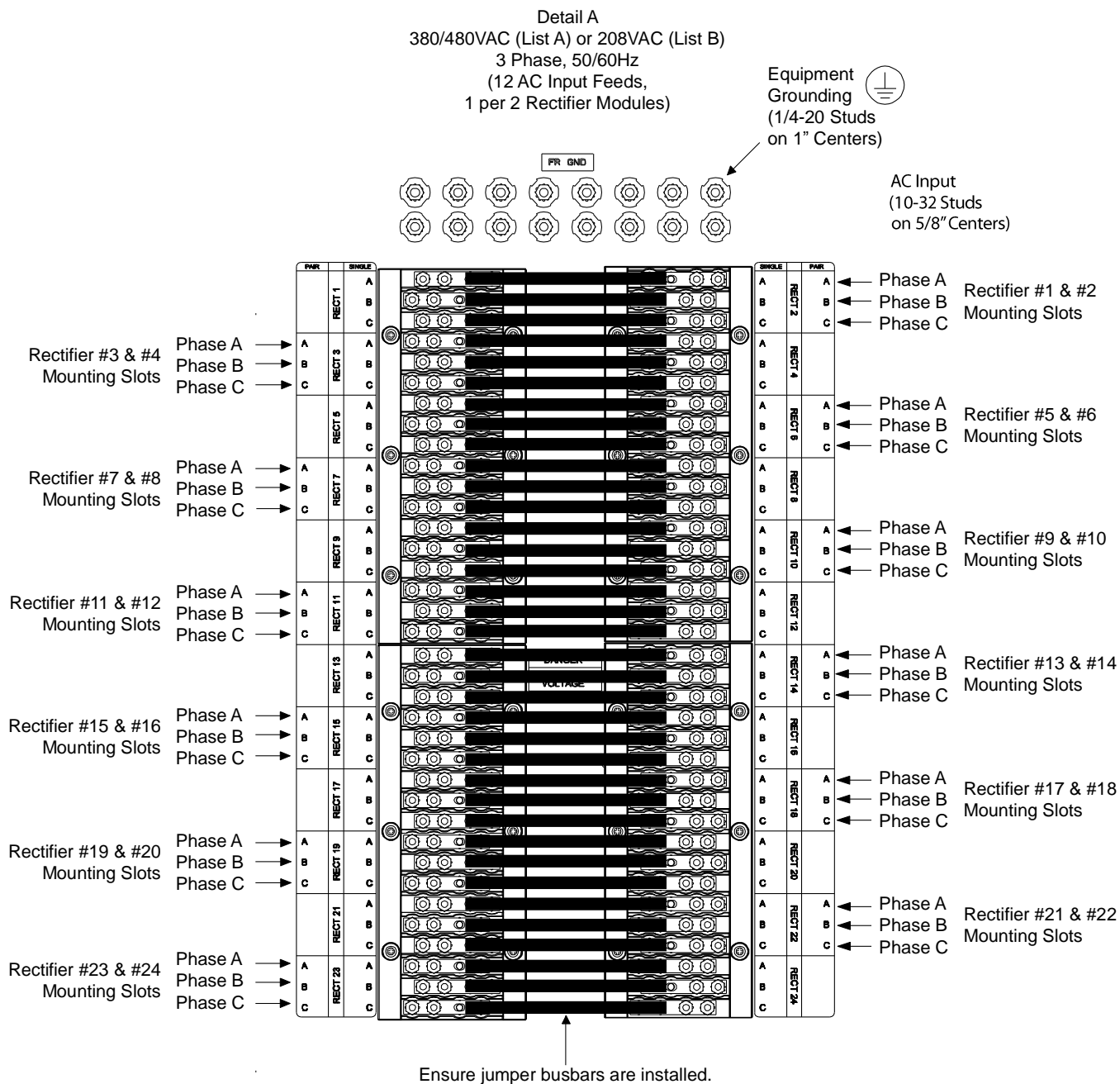
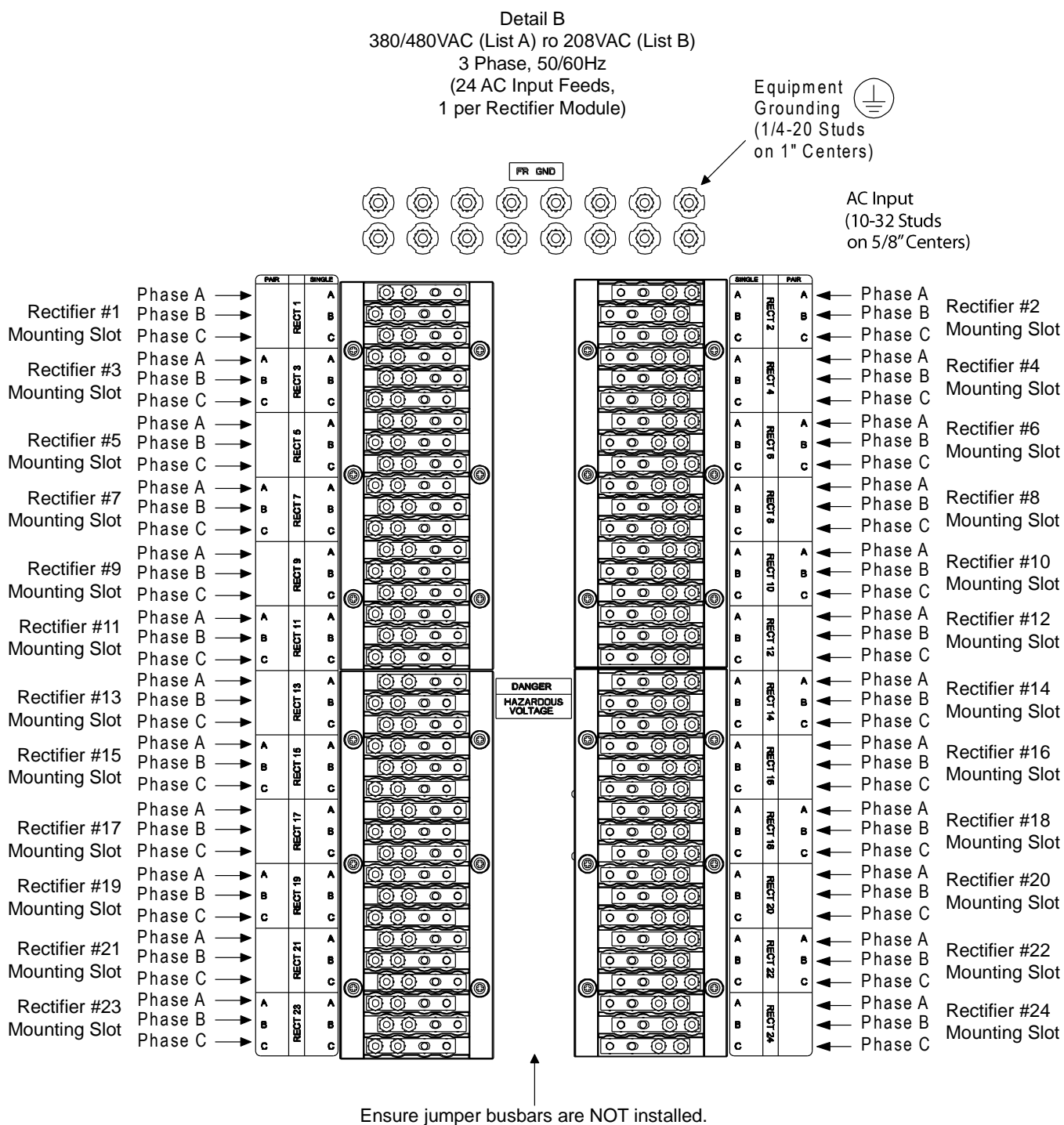

Figure 23: AC Input and AC Input Ground Connections (12 or 24 AC Feeds) (Lists 5 and 13 Power Bays)
(cont'd from previous page)



AC Input Connections to Lists 6 and 14 Bays (6 AC Input Feeds)

Lists 6 and 14 Power Bays provide connections for six (6) AC input branch circuits, one (1) per four (4) Rectifier Module mounting positions. An AC input circuit breaker is also provided for every six Rectifier Module mounting positions. Customer is to provide AC input branch circuit protection.

Refer to **Figure 24** for lead landing locations.

Procedure:

1. Remove the front cover panel and clear plastic shield to gain access to the Rectifier Module AC input busbars.
2. Connect the AC input leads as shown in **Figure 24**.
3. Connect Phase A to the busbar designated "A". Connect Phase B to the busbar designated "B". Connect Phase C to the busbar designated "C".
4. These busbars are equipped with 10-32 studs on 5/8 inch centers. Attach Rectifier Module AC input leads to these using customer supplied two-hole lugs. When lugs are secured using 10-32 inch hardware recommended torque is 23 in lbs when a standard flat washer and lock washer are used.
5. Equipment grounding conductors must be provided with the AC input conductors supplied to each bay. Connect to earth ground, not power system neutral.
6. Refer to **Figure 24** and locate the Rectifier Module AC input frame ground studs (1/4 20 studs on 1" centers). Attach Rectifier Module AC input ground leads to these studs using customer supplied two-hole lugs and mounting hardware. When lugs are secured using 1/4 inch hardware, recommended torque is 84 in lbs when a standard flat washer and lock washer are used.
7. Replace the front cover panel when done.

Figure 24: AC Input and AC Input Ground Connections (6 AC Feeds) (Lists 6 and 14 Power Bays)(cont'd on next page)

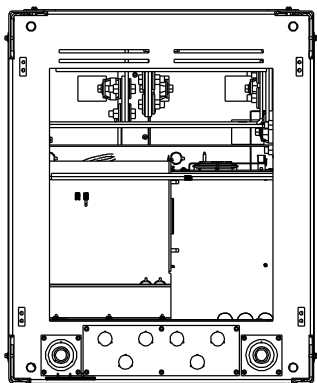

Six (6) 1.125" openings for 3/4" conduit.
 Two (2) conduit plates with 2.5", 1.75", and 1.125" knock-outs for 2", 1.5", and 3/4" conduit.
 Six (6) 1.75" openings for 1.5" conduit (under plate).

Top View
 Power Bay

Note: Rectifier numbering is for wiring identification only. The MCA identifies rectifiers differently.

- Rectifier #1 Mounting Slot
- Rectifier #3 Mounting Slot
- Rectifier #5 Mounting Slot
- Rectifier #7 Mounting Slot
- Rectifier #9 Mounting Slot
- Rectifier #11 Mounting Slot
- Rectifier #13 Mounting Slot
- Rectifier #15 Mounting Slot
- Rectifier #17 Mounting Slot
- Rectifier #19 Mounting Slot
- Rectifier #21 Mounting Slot
- Rectifier #23 Mounting Slot

Front View
 Power Bay

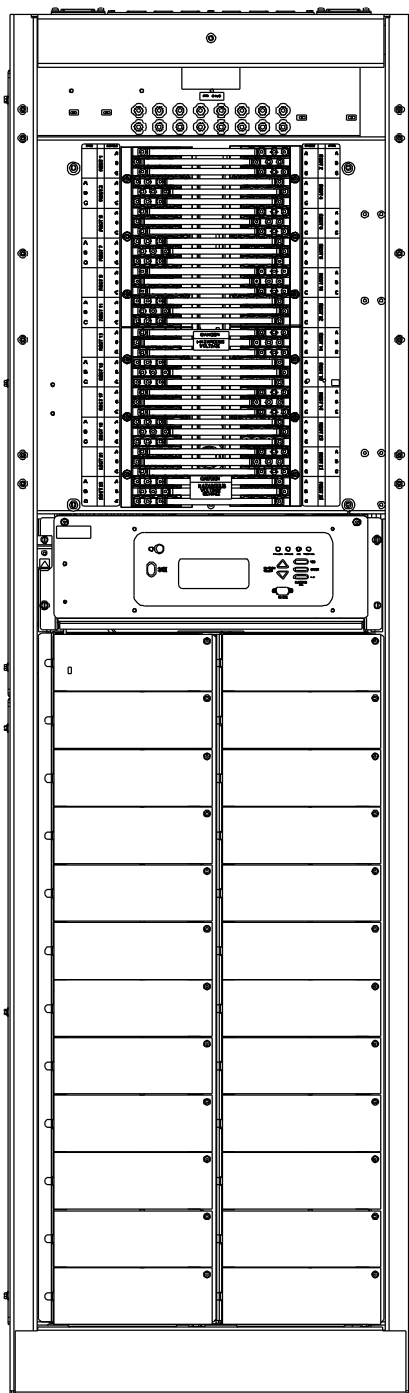

See Detail A
 (6 Feeds)

Front cover panel
 removed in illustration

- Rectifier #2 Mounting Slot
- Rectifier #4 Mounting Slot
- Rectifier #6 Mounting Slot
- Rectifier #8 Mounting Slot
- Rectifier #10 Mounting Slot
- Rectifier #12 Mounting Slot
- Rectifier #14 Mounting Slot
- Rectifier #16 Mounting Slot
- Rectifier #18 Mounting Slot
- Rectifier #20 Mounting Slot
- Rectifier #22 Mounting Slot
- Rectifier #24 Mounting Slot

Figure 24: AC Input and AC Input Ground Connections (6 AC Feeds) (Lists 6 and 14 Power Bays) (cont'd from previous page)

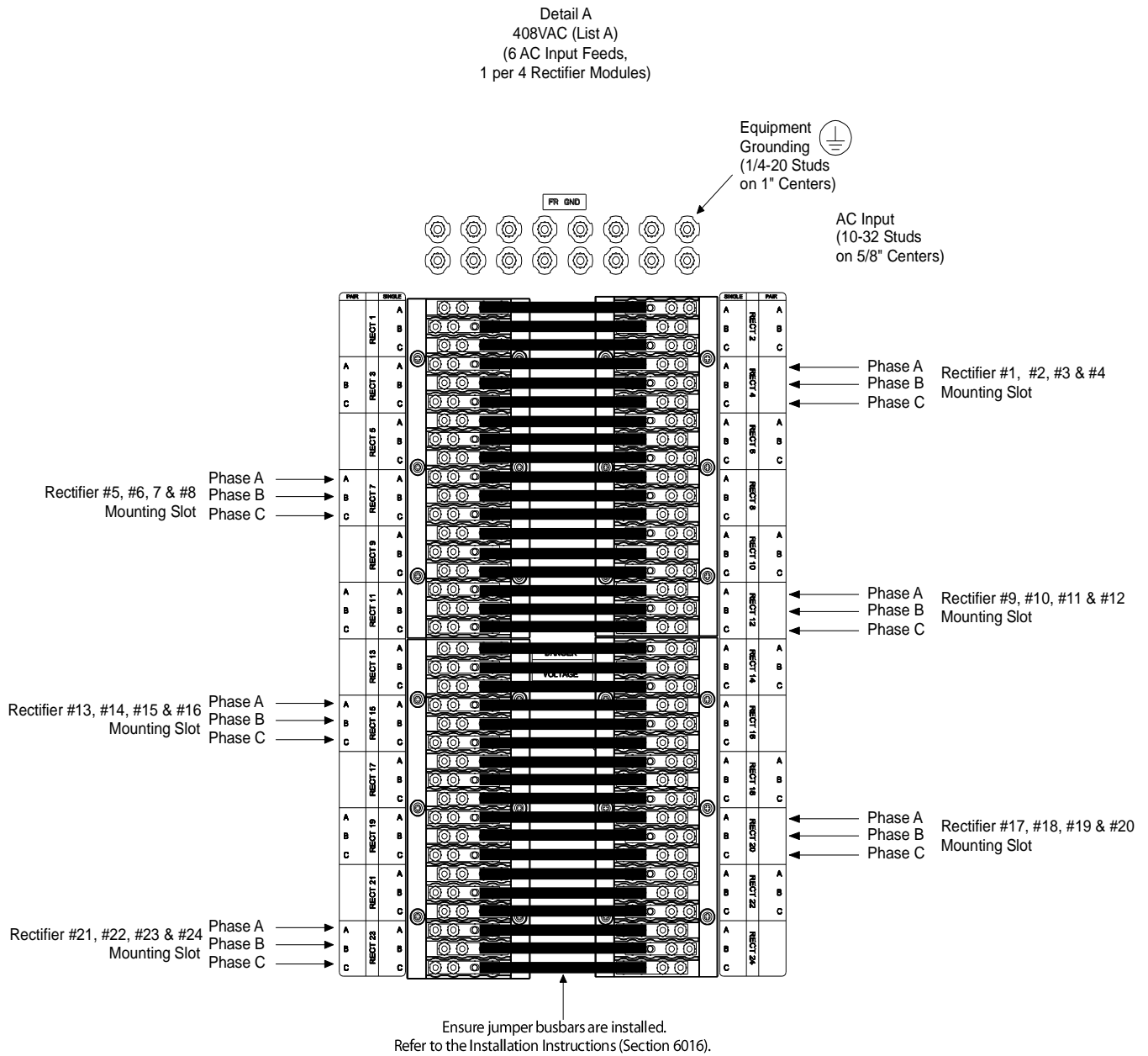

AC Input Connections to Lists 4 and 12 Bays (2 AC Input Feeds)

Lists 4 and 12 Power Bays provide connections for two (2) AC input branch circuits, one (1) per twelve (12) Rectifier Module mounting positions. An AC input circuit breaker is also provided for every two Rectifier Module mounting positions. Customer is to provide AC input branch circuit protection.

Refer to **Figure 25** for lead landing locations.

Procedure:

1. Remove the front cover panel and clear plastic shield to gain access to the Rectifier Module AC input busbars.
2. Connect the AC input leads as shown in **Figure 25**.

Feed 1: Refer to **Figure 25** and locate the Rectifier Module AC input busbars for Feed #1. These busbars are equipped with 3/8 16 studs on 1 inch centers. Attach Rectifier Module AC input leads to these using customer supplied two-hole lugs. When lugs are secured using 3/8 inch hardware; recommended torque is 180 in lbs when a Belleville lock washer is used and 300 in lbs when a standard flat washer and lock washer are used.

Connect Phase A to the terminal designated "A". Connect Phase B to the terminal designated "B".
Connect Phase C to the terminal designated "C".

Feed 2: Refer to **Figure 25** and locate the Rectifier Module AC input busbars for Feed #2. These busbars are equipped with 3/8 16 studs on 1 inch centers. Attach Rectifier Module AC input leads to these using customer supplied two-hole lugs. When lugs are secured using 3/8 inch hardware recommended torque is 180 in lbs when a Belleville lock washer is used and 300 in lbs when a standard flat washer and lock washer are used.

Connect Phase A to the terminal designated "A". Connect Phase B to the terminal designated "B".
Connect Phase C to the terminal designated "C".

3. Equipment grounding conductors must be provided with the AC input conductors supplied to each bay. Connect to earth ground, not power system neutral.

Refer to **Figure 25** and locate the Rectifier Module AC input frame ground studs (1/4 20 studs on 1 inch centers). Attach Rectifier Module AC input ground leads to these studs using customer supplied two-hole lugs and mounting hardware. When lugs are secured using 1/4 inch hardware; recommended torque is 84 in lbs when a standard flat washer and lock washer are used.

4. Replace the front cover panel when done.

Figure 25: AC Input and AC Input Ground Connections (2 AC Feeds) (Lists 4 and 12 Bays)

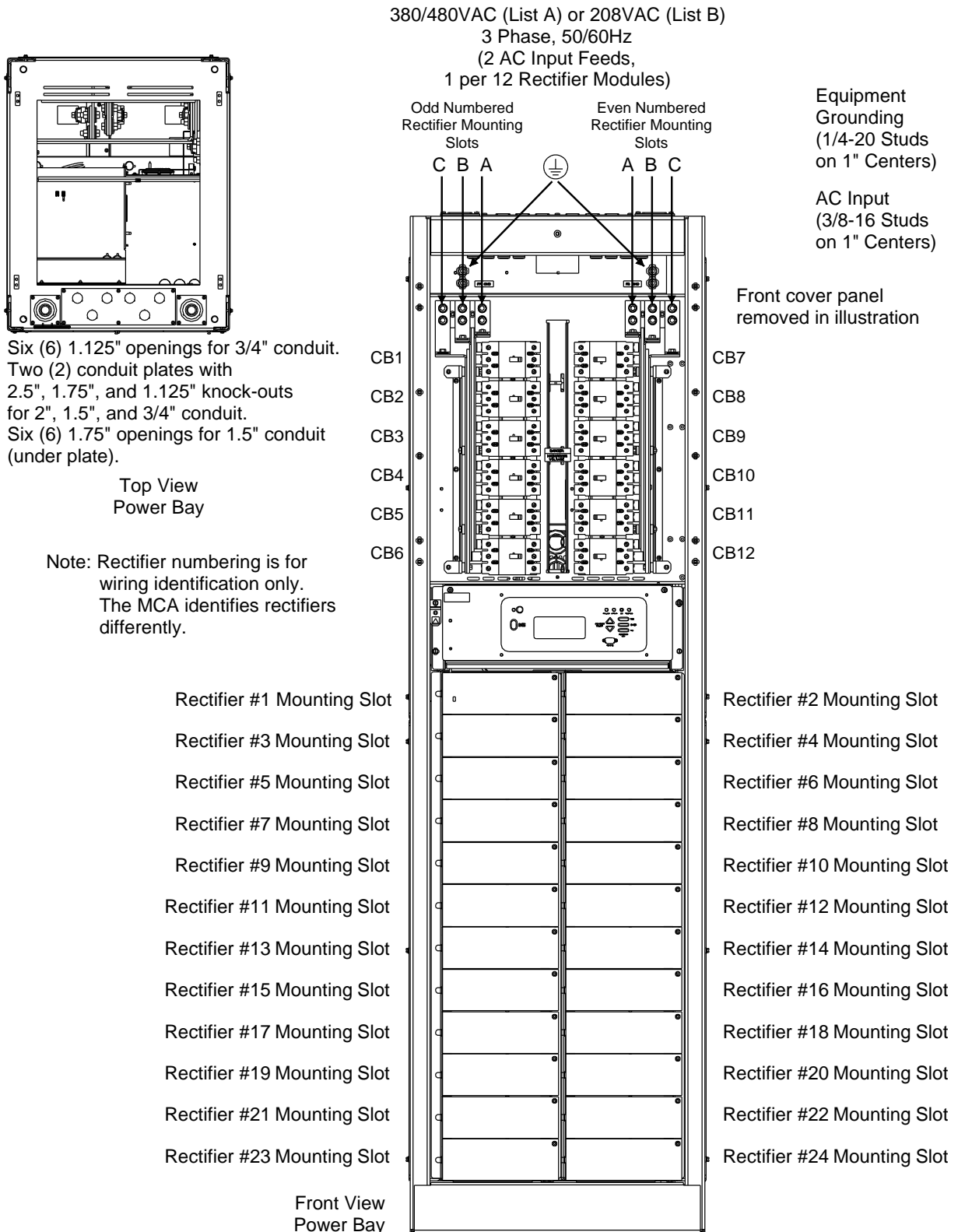

Note: Rectifier numbering is for wiring identification only. The MCA identifies rectifiers differently.

Battery Connections



DANGER! Although battery voltage is not hazardously high, the battery can deliver large amounts of current. Exercise extreme caution not to inadvertently contact or have any tool inadvertently contact a battery terminal or exposed wire connected to a battery terminal. Remove watches, rings, or other jewelry before connecting battery leads.



NOTE! Refer to System Application Guide SAG582140001 for recommended wire sizes and crimp lugs. Refer to drawing 031110100 for lug crimping information. Refer to drawings 031110200 and 031110300 for additional lug information. The SAG and Engineering Drawings can be accessed via the CD (Electronic Documentation Package) furnished with your system. A copy of drawing 031110100 is also located at the end of this manual for your convenience.

Power Bay

Located on the rear top of each bay are 3/8" clearance holes on 1" centers. Attach battery leads to these using customer supplied two-hole lugs and mounting hardware. When lugs are secured using 3/8 inch hardware; recommended torque is 180 in lbs when a Belleville lock washer is used and 300 in lbs when a standard flat washer and lock washer are used.

Refer to **Figure 26** for battery landing locations.

The System's Positive Battery Busbar must be grounded. Refer to the National Electrical Code, applicable local codes, and your specific site requirements for grounding specifications.

Distribution Bay

Located on the rear top of each bay are 3/8" clearance holes on 1" centers. Attach battery leads to these using customer supplied two-hole lugs and mounting hardware. When lugs are secured using 3/8 inch hardware; recommended torque is 180 in lbs when a Belleville lock washer is used and 300 in lbs when a standard flat washer and lock washer are used.

Refer to **Figure 27** for battery landing locations.

The System's Positive Battery Busbar must be grounded. Refer to the National Electrical Code, applicable local codes, and your specific site requirements for grounding specifications.

Figure 26: Battery Connection to Rear of Power Bay

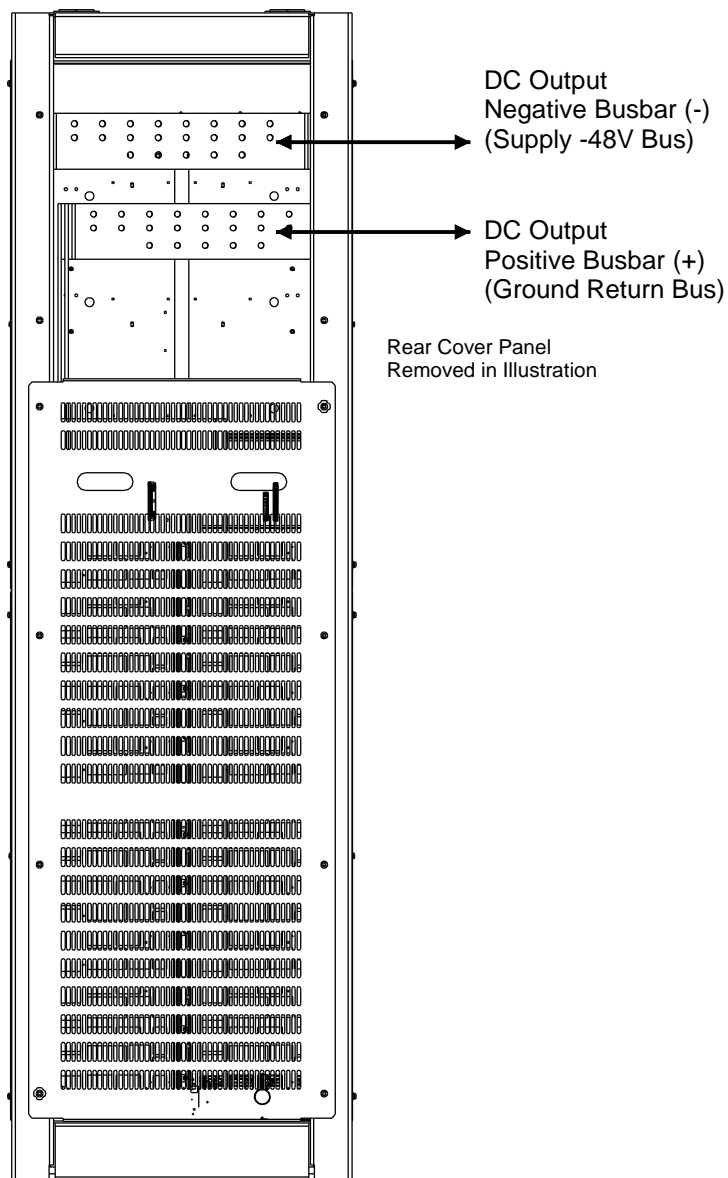
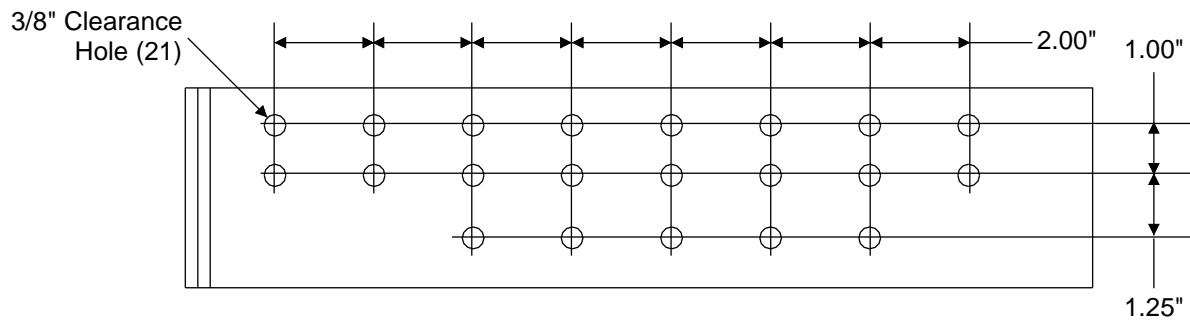

Rear View
Power Bay

Figure 27: Battery Connection to Rear of Distribution Bay

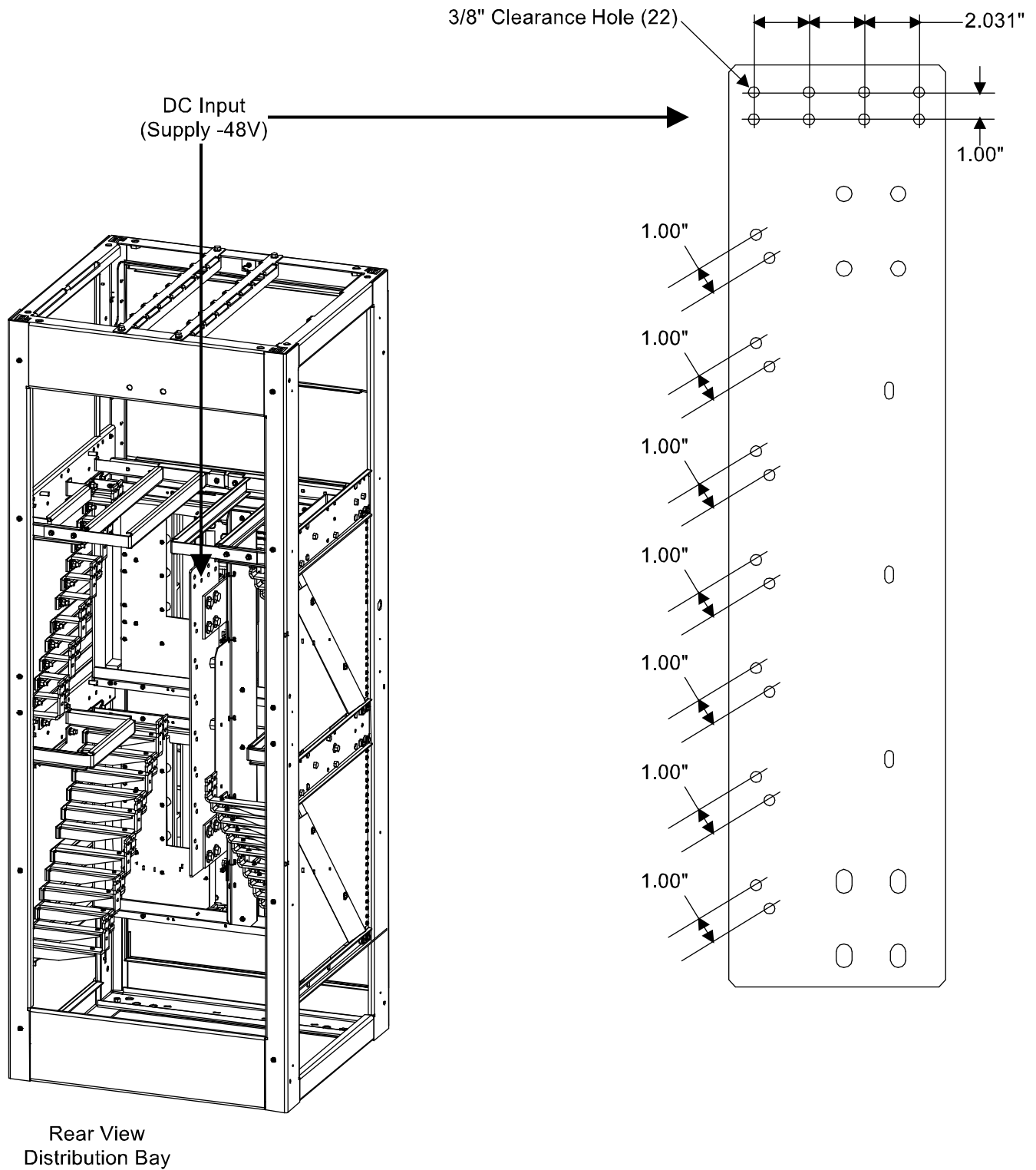

Re-Install Shields and Cover Panels

1. Replace all shields and cover panels that were removed when performing the procedures.
 - For rectifier mounting positions NOT populated with Rectifier Modules, replace the mounting position blank cover panel. Use the supplied grounding washer with the screw to secure the panel.
 - Replace the front AC cover panel to each Power Bay. Use the supplied grounding washers with two of the screws to secure the panel (one per side).
 - Replace the rear cover panel to each Power Bay. Use the supplied grounding washers with two of the screws to secure the panel (one per side).
 - Replace the two rear cover panels to each Distribution Bay.
 - If the outside sides of the end bays do not have side cover panels, install them now (two per side). Note that ground washers are used with each screw securing the side cover panels.

MCA “Alternate Current Limit” Feature



NOTE! Requires MCA firmware version 2.2.0.6, or later.

The MCA Alternate Current Limit feature provides a means to limit the output current of all rectifiers based on the state of an external signal. The rectifier output current is limited to a percentage of rectifier output capacity as configured by the user. A binary input on an installed MCA I/O circuit card is used to monitor the external signal that triggers the current limiting action.

Admonishments

Circuit Card Handling

Refer to the section *Installing MCA and LMS Circuit Cards* prior to installing the MCA I/O circuit card.

Requirements and Conditions

An external signal must be provided to indicate to the MCA to place the rectifiers in the “Alternate Current Limit” mode. The signal must be wired to binary input #4 of the MCA I/O circuit card.

MCA “Power Share” Feature



NOTE! Requires MCA firmware version 2.0.0.11, or later.

The MCA Power Share feature allows you to connect a Spec. No. 582140001 Power System (referred to as “New Power System” in this document) to an existing DC power system (referred to as “Existing Power System” in this document) instead of extending or completely replacing the Existing Power System.

Admonishments

General Safety



DANGER! TECHNICIANS MUST FOLLOW APPROVED SAFETY PROCEDURES.

Performing the following procedures exposes technicians to hazards. These procedures should be performed by qualified technicians familiar with the hazards associated with this type of equipment. These hazards may include shock, energy, and/or burns. To avoid these hazards:

- a) The tasks should be performed in the order indicated.
- b) Remove watches, rings, and other jewelry.
- c) Prior to contacting any uninsulated surface or termination, use a voltmeter to verify that no voltage or the expected voltage is present.
- d) Wear eye protection, and use recommended tools.
- e) Use insulated tools.

(To avoid danger to the installer or damage to the equipment, the tools used in this procedure should have insulated grips. All exposed metal shafts, extensions, handles, etc. should be completely insulated with a minimum of three half-lapped layers of electrical tape. Ensure that wrenches with more than one working end have only one end exposed.)

DC Input/Output Voltages



DANGER! Connecting the 582140001 Power System to an existing power system for “Power Share” mode involves working on live equipment carrying live loads. This system produces DC power and requires battery to be connected to it. Although the DC voltage is not hazardously high, the PCUs and/or battery can deliver large amounts of current. Exercise extreme caution not to inadvertently contact or have any tool inadvertently contact a battery terminal or exposed wire connected to a battery terminal. NEVER allow a metal object, such as a tool, to contact more than one termination at a time, or to simultaneously contact a termination and a grounded object. Even a momentary short circuit can cause explosion and injury. Remove watches, rings, or other jewelry before connecting leads. Cover any live busbars with a canvas sheet to prevent short circuits caused by falling tools or parts.

Requirements and Conditions

The two DC power systems must be connected in parallel as described in the “PARALLELING THE EXISTING AND NEW POWER SYSTEMS” procedure.

Before paralleling the two systems, the following conditions must be met for proper Power Share function.

- The voltage of the New Power System must be set to the same level as that of the Existing Power System.

- The remote sense, if used, of both the new and Existing Power System's must be connected to the same point.
- If batteries are used, they must be of the same type.
- All the functions specific to the Existing and New Power Systems and which depend on the voltage or which act on the voltage must be disabled from the Existing and New Power Systems (note that this is automatically done on the New Power System when the Power Share feature is programmed). This includes...
 - any equalization function,
 - any temperature compensation function,
 - any charge control function,
 - any battery discharge test function, and
 - any invalid current alarm.

Paralleling the Existing and New Power Systems

Refer to the following when a Spec. No. 582140001 Power System is to be operated in parallel with an existing power system in the "Power Share" mode.

Preparing the Existing and New Power Systems

- Install and turn-up the New Power System as describe in these Installation Instructions.
- Set the float voltage on both the existing and New Power Systems to the same level. Temperature compensation functionality, if used, must be disabled on both power systems.

Paralleling the Systems

- Connect the Positive Battery (Ground Return +48V) and Negative Battery (Supply -48V) overhead busbars of the New Power System to the main charge busbars (rectifier side of the shunt) on the Existing Power System. Size the cable for the largest current between systems. Refer to **Figure 28**.

Note 1: The connections between the two power systems should be done with power cables appropriately sized to be capable of carrying the maximum current that can circulate between the two power systems.

Note 2: If the Existing Power System incorporates a main plant shunt, the connections of the cables from the New Power System to the Existing Power System shall be made on the main charge busbars (rectifier side of the shunt).

Note 3: To compensate for voltage drop, it is recommended to connect the New Power System's remote sense leads to the same point of sensing as the Existing Power System.

Note 4: There shall be only one battery return reference (BRR) cable for the two power systems. If the cable is appropriately sized on the Existing Power System, keep it as the BRR for both power systems. If the cable is not appropriately sized on the Existing Power System, install a new BRR cable and connect it preferably to the New Power System since the Existing Power System may eventually be phased out.

- Note 5:** If battery disconnect units (BDUs) are used on the new or Existing Power System, these shall be wired in such a way as to be all triggered simultaneously in order to prevent any overloading of these.
- Note 6:** For the size and number of bridge cables between the two power systems, take into consideration the voltage drop, the available connecting points in each system, as well as the fact that these cables are unfused and shall therefore be run on a dedicated cable rack. “C” or “H” taps may be used to make full use of available connecting points.
- Note 7:** The legacy system retains the function of its controller and the percent of load on each plant is controlled by the LPS MCA. Alarms may be sent individually from each plant, or combined using an LMS1000 and the programmable relays resident in the LPS controller.
- Note 8:** Add a label on both power systems to indicate that these are operating in the Power Share Mode with each other.
- Note 9:** The use of an MCA I/O card will allow the user to replace the total load on the LPS MCA with the reading of a main shunt, such as one in a chandelier application, or add the reading of load shunt in the legacy plant to the internally calculated load of the LPS.
- Note 10:** The LMS allows the MCA programmable relays to send SNMP traps, and respond to SNMP gets as well.
- Note 11:** LMS Function Channel # 64 is dedicated for summing the total current output of conventional rectifiers in a hybrid application. The channel name for F64 will default to “Total Rectifier Output.” The LMS updates the MCA with the calculated value for the configured program line. The MCA looks for a value on LMS Function Channel #64 and adds that to the internally calculated total PCU load.

Figure 28: Connecting the Two Plants for “Power Share” Mode

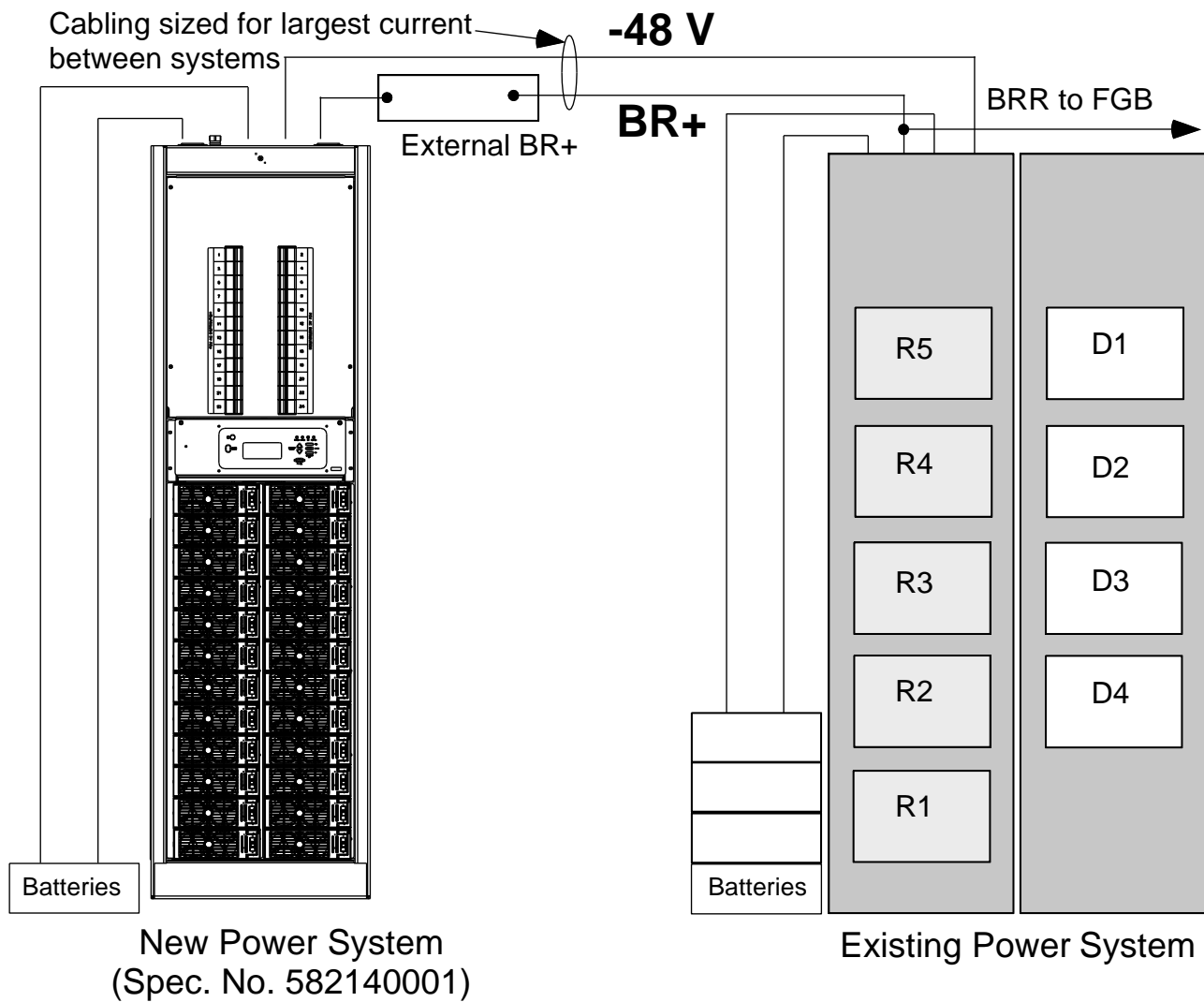

Operation

After the “Power Share” cabling is completed, refer to the *User Instructions* (Section 6017) to program the “Power Share” feature.

Also verify the operation of the “Power Share” feature as described in the *User Instructions* (Section 6017).

Connecting the 582140001 System to Other Systems

 **NOTE!** Connections to systems with an existing MCA requires that the LMS Dual MCA Software Option be installed.

Connecting a 582140001 Main Power Bay to a 582121100 Power Bay and/or 582121900/582121901 Distribution Bay (MCA and LMS Interconnections)

See **Figure 29**.

Interface Notes

1. Program and connect the two systems for the Power Share feature in the 582140001 System.
2. Lockout local access to the MCA located in the 582121100 Power Bay or 582121900/582121901 Distribution Bay.
3. Ensure remote access to the MCA located in the 582121100 Power Bay or 582121900/582121901 Distribution Bay is enabled.
4. Install the RS-485 option (if not already furnished) onto the MCA located in the 582121100 Power Bay or 582121900/582121901 Distribution Bay.

If RS-485 option is already installed on the MCA located in the 582121100 Power Bay or 582121900/582121901 Distribution Bay, disconnect the cable.

5. Connect the LMS in the 582140001 System to the MCA in the 582121100 Power Bay or 582121900/582121901 Distribution Bay (connect cable from the LMS RS-485 connector in the 582140001 System to the RS-485 connector on the MCA Panel in the 582121100 Power Bay or 582121900/582121901 Distribution Bay).
6. If an LMS1000 is installed in the 5821900/582121901 Distribution Bay and contains I/O cards, replace the Main LMS CPU card with an Expansion LMS CPU Card (P/N 506153), and connect the LMS1000 to the LMS network in the 582140001 System.
7. If a DGU is installed in 582121900/582121901 Distribution Bay, then...
 - a) Have LMS Gateway Port Software Option installed.
 - b) Connect a cable from the DGU local port to the connector located on the front of the LMS CPU card installed in the 582140001 Main Power Bay. This cable is a straight through cable with a DB-9 (female) end and a DB-9 (male) end. This cable connects between the DGU COM1 card, Port A, and the LMS RS-232 port located on the front of the LMS card assembly.

 **NOTE!** DGU communication is a telnet gateway through the LMS to the DGU. It IS NOT communication between the DGU and the LMS. Alarms in the DGU cannot be recognized by the LMS unless they are individually hard wired.

Figure 29:



Connecting a 582140001 Main Power Bay to a Medium Vortex Power System when the MCA is located in the PCU Intelligence Shelf (MCA Interconnections)

See **Figure 30**.

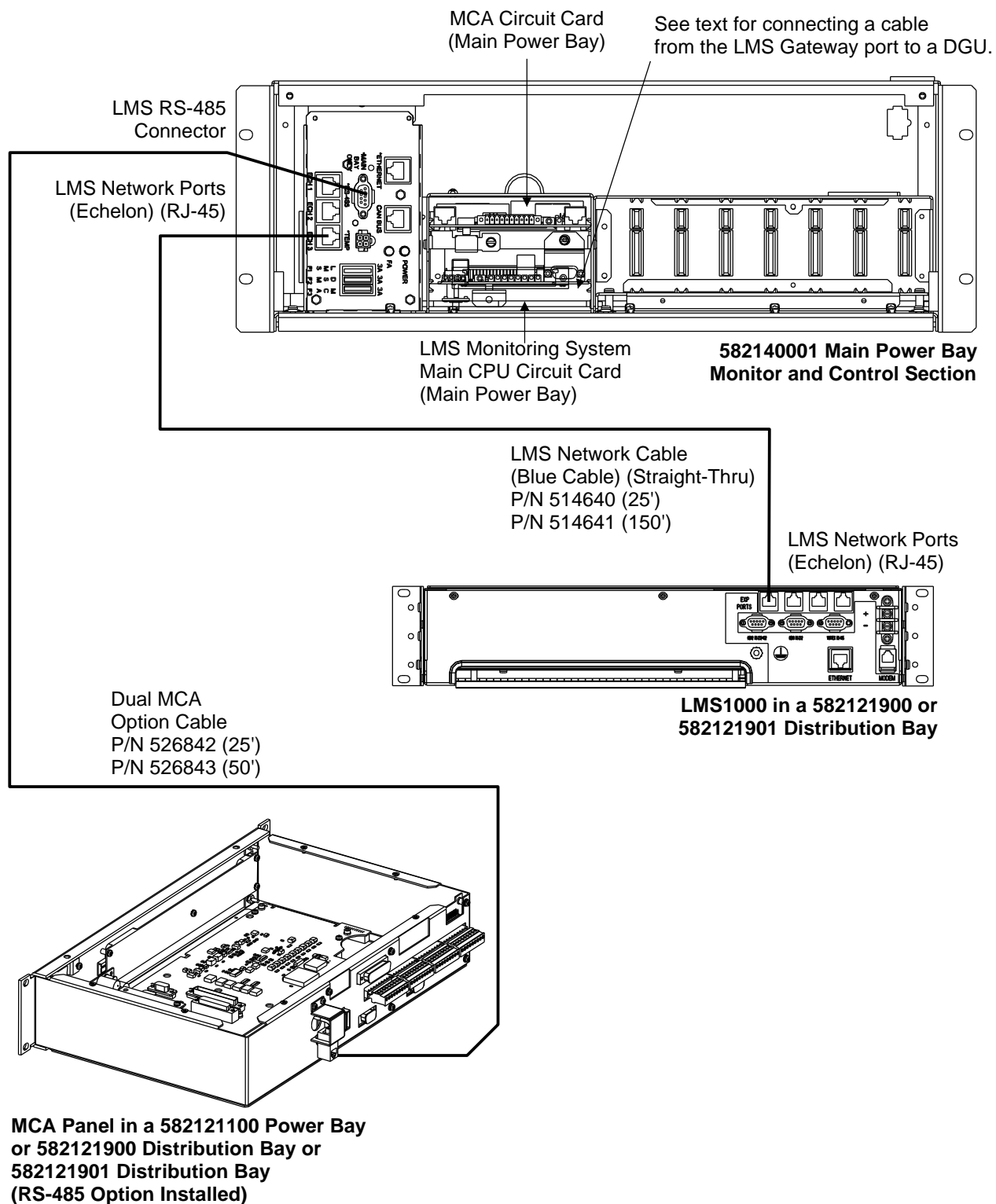
Interface Notes

1. Program and connect the two systems for the Power Share feature in the 582140001 System.
2. Lockout local access to the MCA located in the Vortex Power System.
3. Ensure remote access to the MCA located in the Vortex Power System is enabled.
4. Install the RS-485 option (if not already furnished) onto the MCA in the Vortex Power System.

If RS-485 option is already installed on the MCA in the Vortex Power System, disconnect the cable.

5. Connect the LMS in the 582140001 System to the MCA in the Vortex Power System (connect cable from the LMS RS-485 connector in the 582140001 System to the RS 485 connector on the MCA option in the Vortex Power System).

Figure 30:

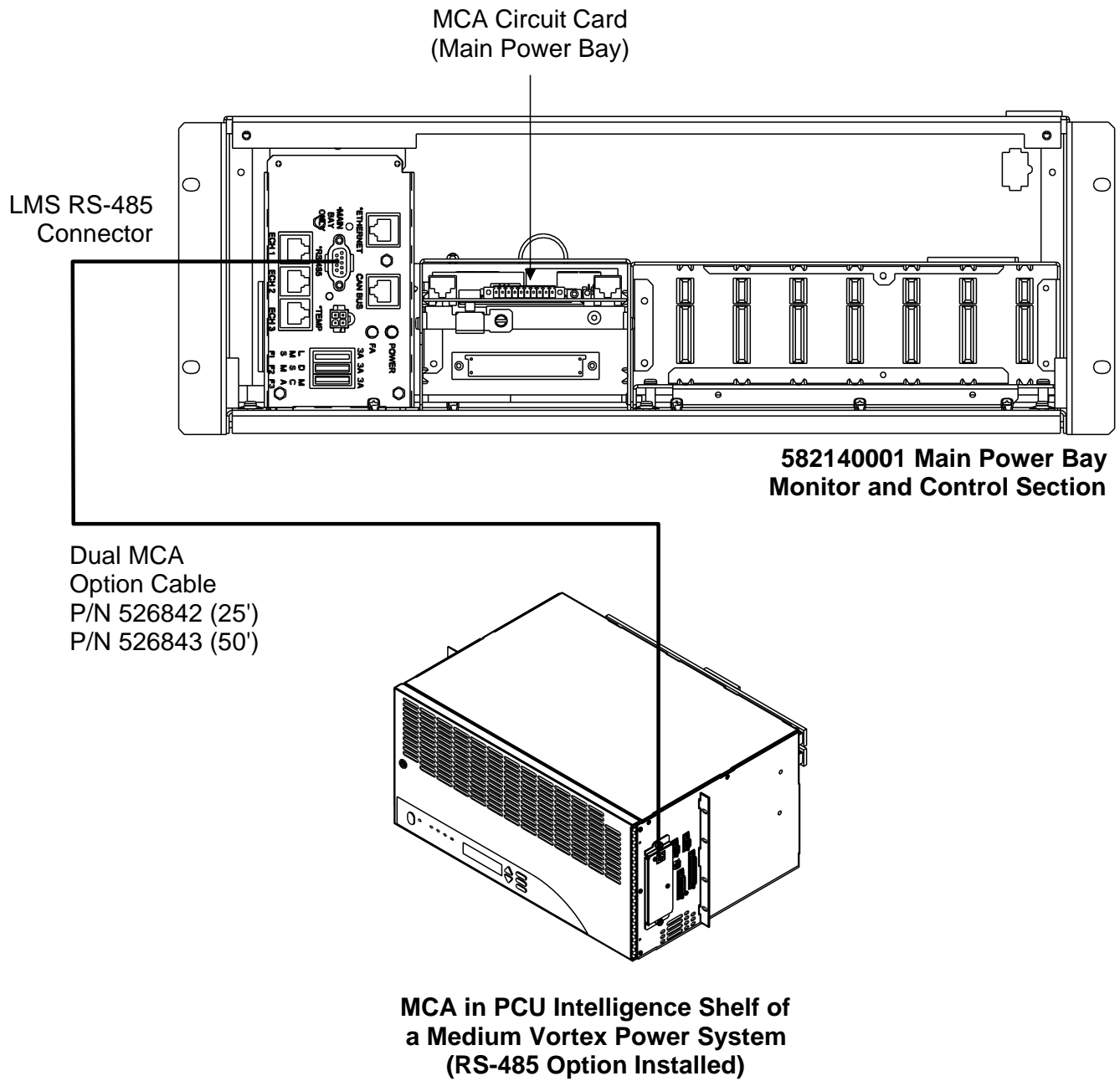

Connecting a 582140001 Main Power Bay to a Medium Vortex Power System when the MCA is Located in the Distribution Cabinet (MCA and LMS Interconnections)

See **Figure 31**.

Interface Notes

1. Program and connect the two systems for the Power Share feature in the 582140001 System.
2. Lockout local access to the MCA located in the Vortex Power System.
3. Ensure remote access to the MCA located in the Vortex Power System is enabled.
4. Install the RS-485 option (if not already furnished) onto the MCA in the Vortex Power System.

If RS-485 option is already installed on the MCA in the Vortex Power System, disconnect the cable.

5. Connect the LMS in the 582140001 System to the MCA in the Vortex Power System (connect cable from the LMS RS-485 connector in the 582140001 System to the RS 485 connector on the MCA option in the Vortex Power System).
6. If an LMS1000 is installed in the Vortex Power System and contains I/O cards, replace the Main LMS CPU card with an Expansion LMS CPU Card (P/N 506153), and connect the LMS1000 to the LMS network in the 582140001 System.

Figure 31:

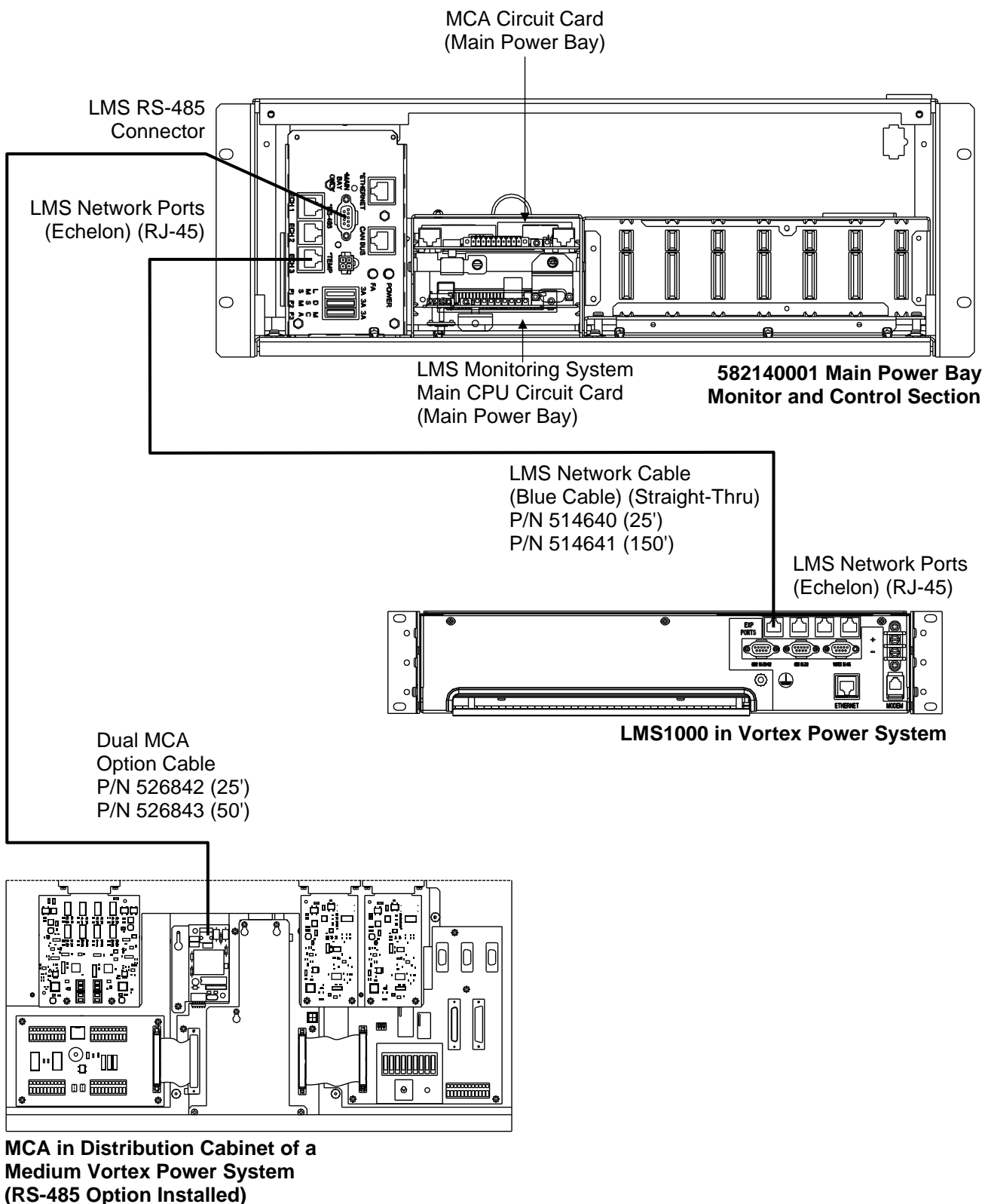

Connecting a 582140001 Main Power Bay to a Legacy Power System (LMS Interconnections)

See **Figure 32**.

Interface Notes

1. Connect shunt leads from the Legacy System to an LMS analog card installed in the 582140001 System.
2. Connect RFA leads from the Legacy System to an LMS binary card installed in the 582140001 System.
3. Connect FA leads from the Legacy System to an LMS binary card installed in the 582140001 System.
4. For each legacy rectifier, program an LMS Energy Management Channel using the associated inputs. Program the LMS for Energy Management. Refer to the LMS User document.
5. If the Legacy System requires sequencing of rectifiers, program the LMS sequencing option. Sequencing also requires an LMS Relay Card(s) (58650550040) to be installed in the 582140001 system and connected to the legacy rectifiers. Refer to the LMS User document.
6. Update the LMS Function Channel 0063 program line to sum the analog inputs used in Step 1) for distribution shunts.
7. Update the LMS Function Channel 0064 program line to sum the analog inputs used in Step 1) for rectifier shunts.
8. Update the LMS LED Channel 0007 program line to include the binary inputs used in Step 3).

Figure 32:

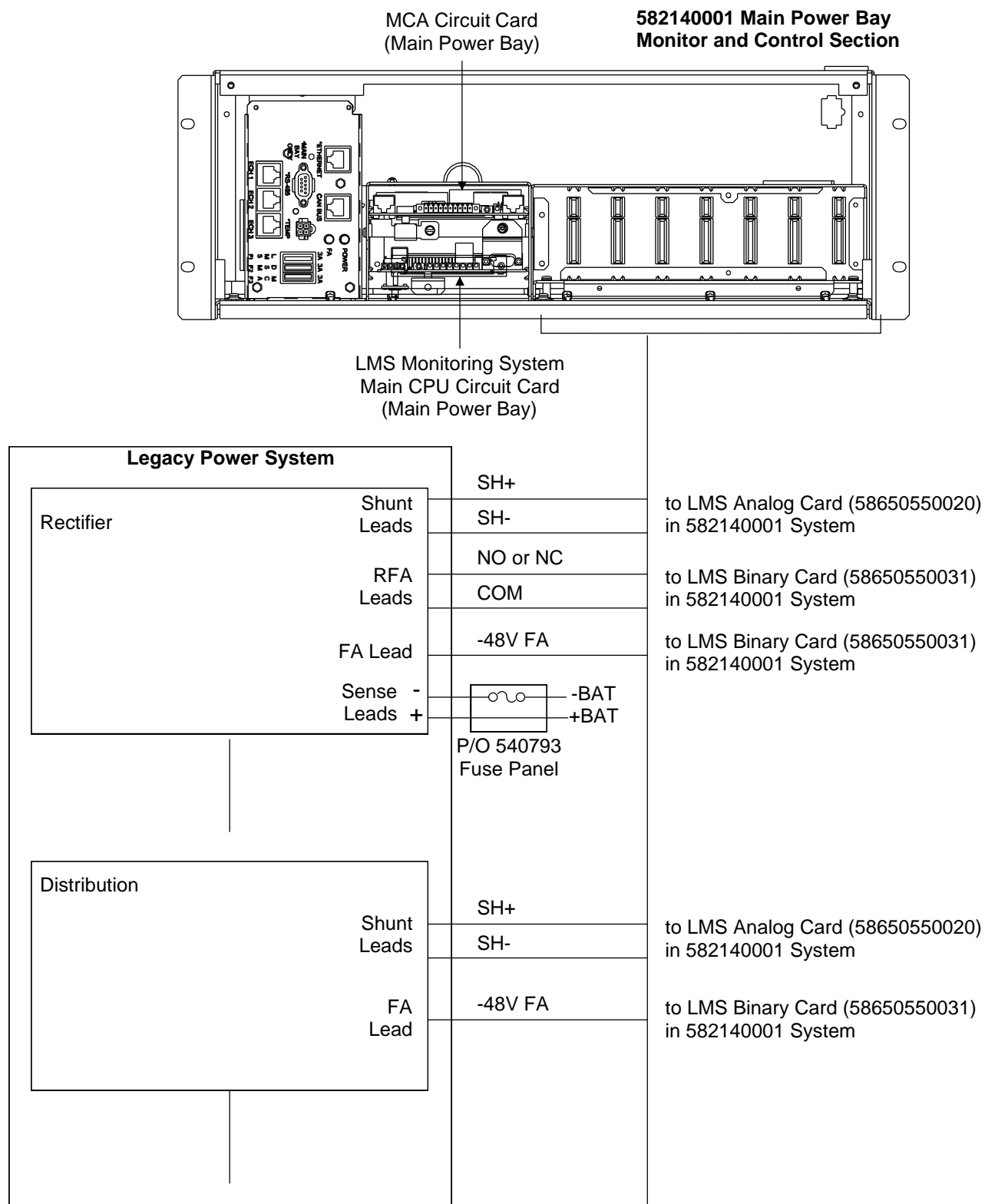

INSTALLING THE RECTIFIER MODULES AND INITIALLY STARTING THE POWER SYSTEM

Installing the Rectifier Modules



ALERT! In order to prevent damage to the latching mechanism, do not use excessive force on the rectifier handle when pushing the rectifier into the bay.

The Rectifier Module is hot swappable. It can be installed with the system operating.

Procedure

1. Remove the blank panel from the Rectifier Module mounting position. Save this panel. The panel must be re-installed if a Rectifier Module is removed.
2. Place the Rectifier Module into an unoccupied mounting position without sliding it in completely.
3. Push the “Safety Latch Release” located on the front of the Rectifier Module UP. Refer to **Figure 33** for an illustration.
4. Gently push the Rectifier Module into the shelf until it stops. Note that the Rectifier Module will NOT be completely seated in the shelf until the next step is performed.
5. Push the “Safety Latch Release” located on the front of the Rectifier Module DOWN. Gently push the Rectifier Module into the shelf until it is completely seated.
6. Push the Rectifier Module’s handle in and secure the rectifier to the bay by tightening the captive fastener located on the handle.
7. Repeat the above steps for each Rectifier Module being installed in the system.
8. After the Rectifier Modules are physically installed in the mounting shelf(s), they are ready for operation immediately after power is supplied to them.

Figure 33: Rectifier Module Handle and Safety Latch

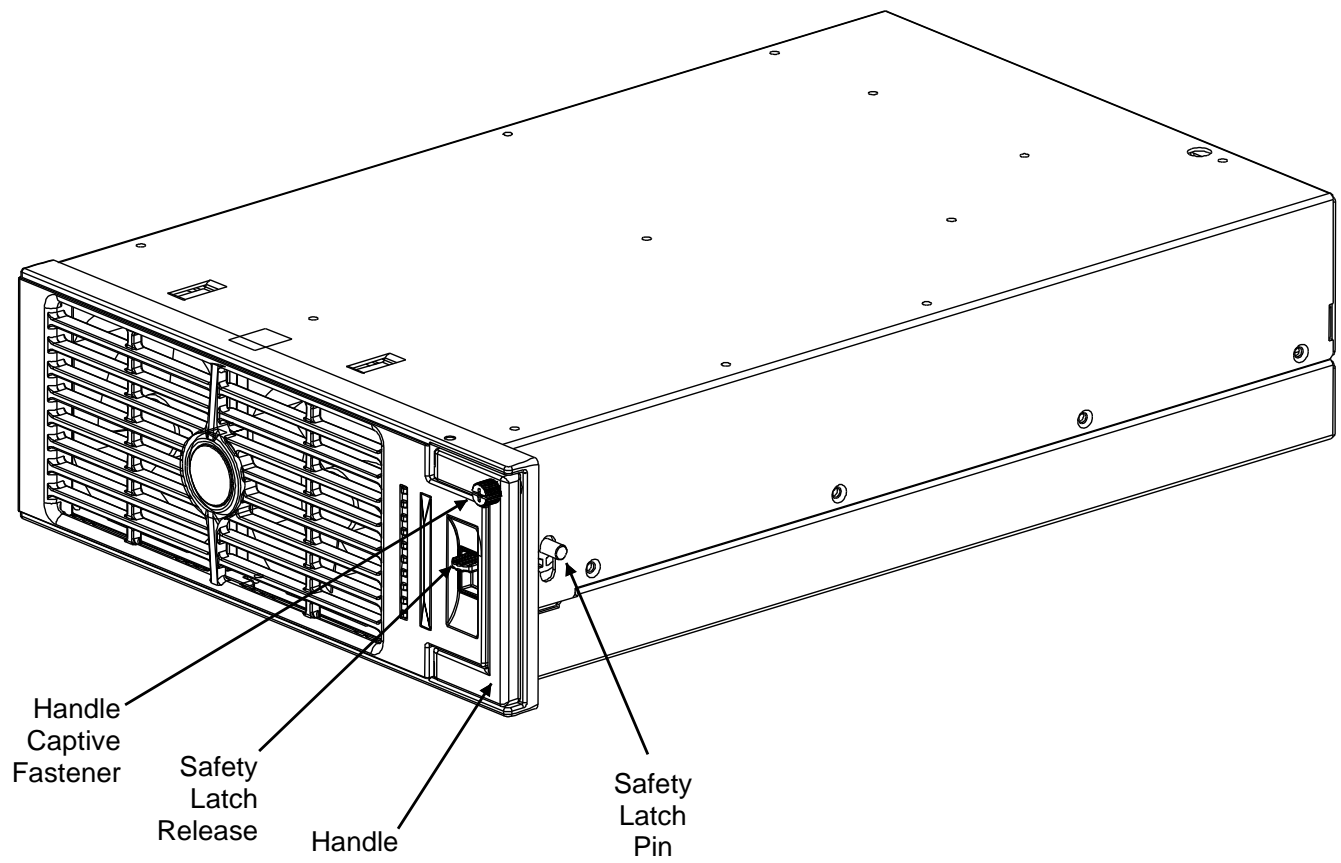

Setting Switch S1 on the MCA Circuit Card in the Primary Power Bay

The MCA circuit card (P/N 509478) installed in the Primary Power Bay contains Switch S1. Set the individual switches of S1 per Site requirements. Refer to **Figure 34** for switch location and **Table 4** for switch functions.

Table 4: MCA Circuit Card Switch S1 Functions

The individual switches of S1 have the following functions. Note that the switch ON position is the UP position.		
Switch of S1	Designation	Function
1	MCA	When in the ON position, the MCA section of the circuit card is disabled.
2	MON	When in the ON position, changing Power System settings via LMS is disabled.
3	KEY	When in the ON position, changing Power System settings via MCA Keypad is disabled.
4	PRO	When in the ON position, the remote uploading of new firmware into the circuit card is forced. This switch is used for diagnostic purposes only.

Setting Jumper J4 on MCA Distribution Bus Monitoring Circuit Cards

The MCA Distribution Bus Monitoring Circuit Cards (P/N 524982) installed in each bay contain jumper J4. Set this jumper on each circuit card per Site requirements. Refer to **Figure 34** for jumper location and the follow for a description of the jumper.

 **NOTE!** If a jumper is changed on a live system, an alarm is generated. Update Inventory to clear the alarm.

Jumper Description

If the jumper is **installed** between the two pins of J4 on **ALL** MCA Distribution Bus Monitoring Circuit Cards, then there is **NO A or B distribution designation** in the MCA display of distribution items. If any MCA Distribution Bus Monitoring Circuit Card has the jumper **removed**, that distribution bus is **designated as B**. Those that have the jumper **remaining (installed)** are **designated as A**.

Figure 34: Circuit Card Switch and Jumper Option Locations (cont'd on next page)

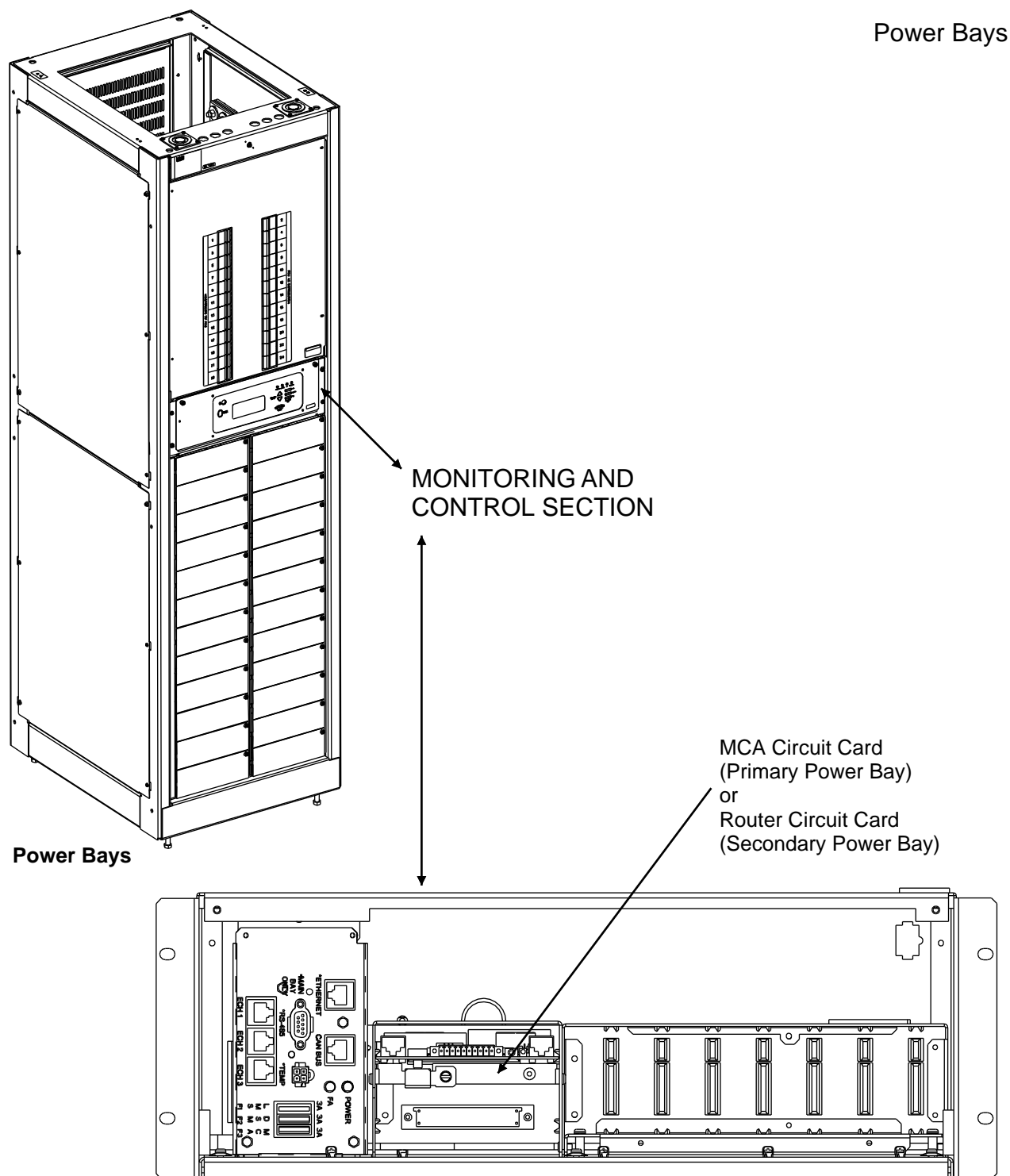

Front door assembly removed in illustration for clarity.

Figure 34: Circuit Card Switch and Jumper Option Locations (cont'd from previous page, cont'd on next page)

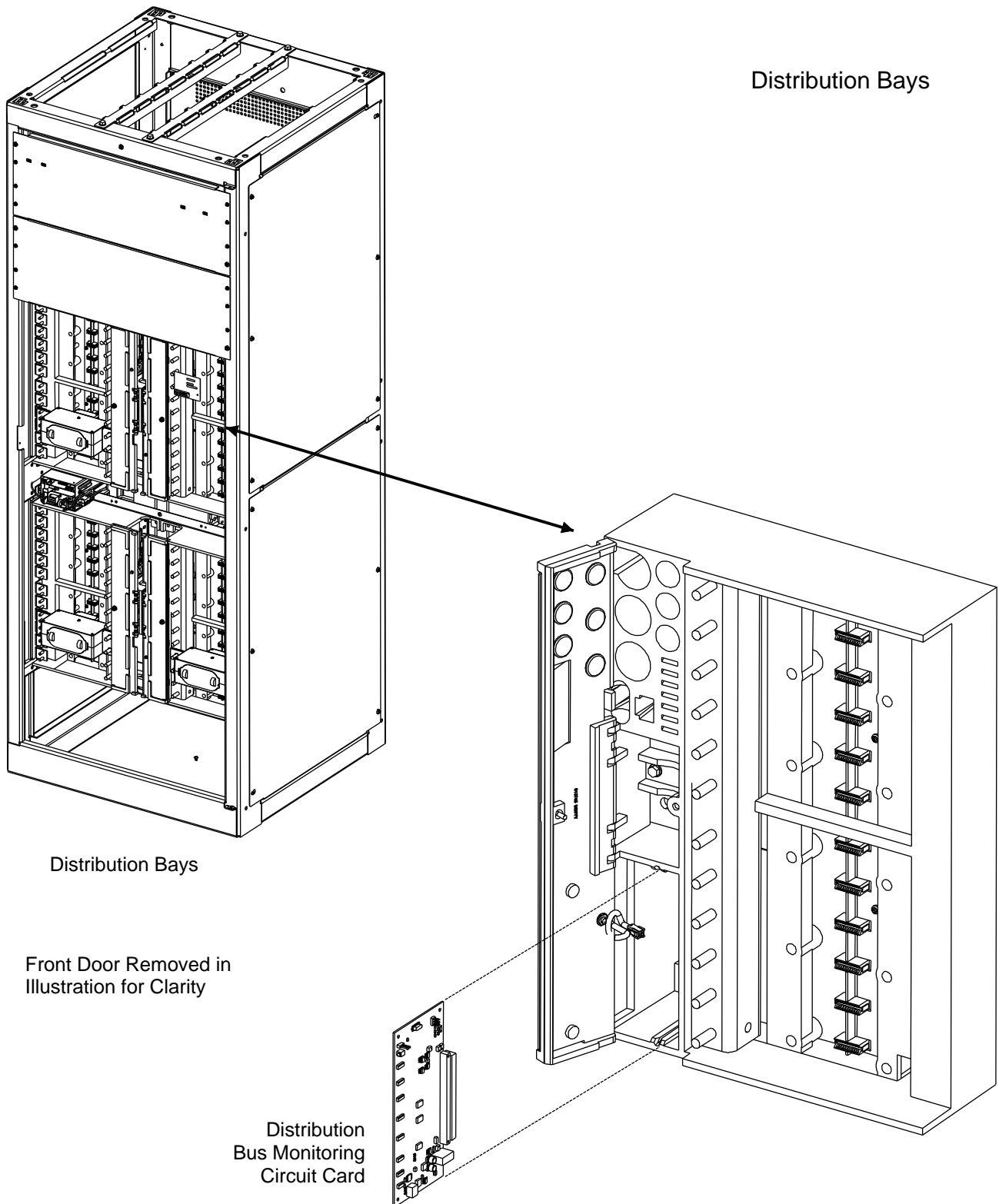
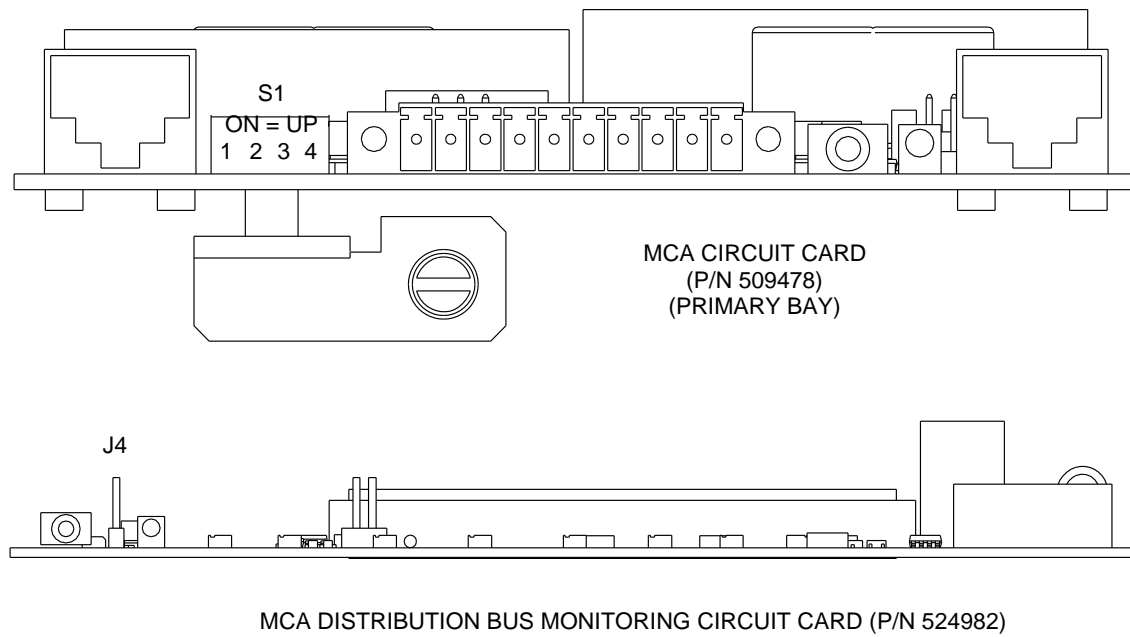

Figure 34: Circuit Card Switch and Jumper Option Locations (cont'd from previous page)



Initially Starting, Configuring, and Checking System Operation

Observe the Following Admonishment



ALERT! Performing various steps in the following procedures may cause a service interruption and/or result in the extension of alarms. Notify any appropriate personnel before starting this procedure. Also notify the personnel when this procedure is completed.

MCA (Meter, Control, Alarm Panel)

MCA Local Control Panel and Display

In the following procedures, all controls and indicators are located on the MCA Local Control Panel, unless otherwise indicated. The MCA Local Control Panel is located on the front of the Primary Power Bay. See **Figure 35**.

Figure 35: MCA Control Panel and Display

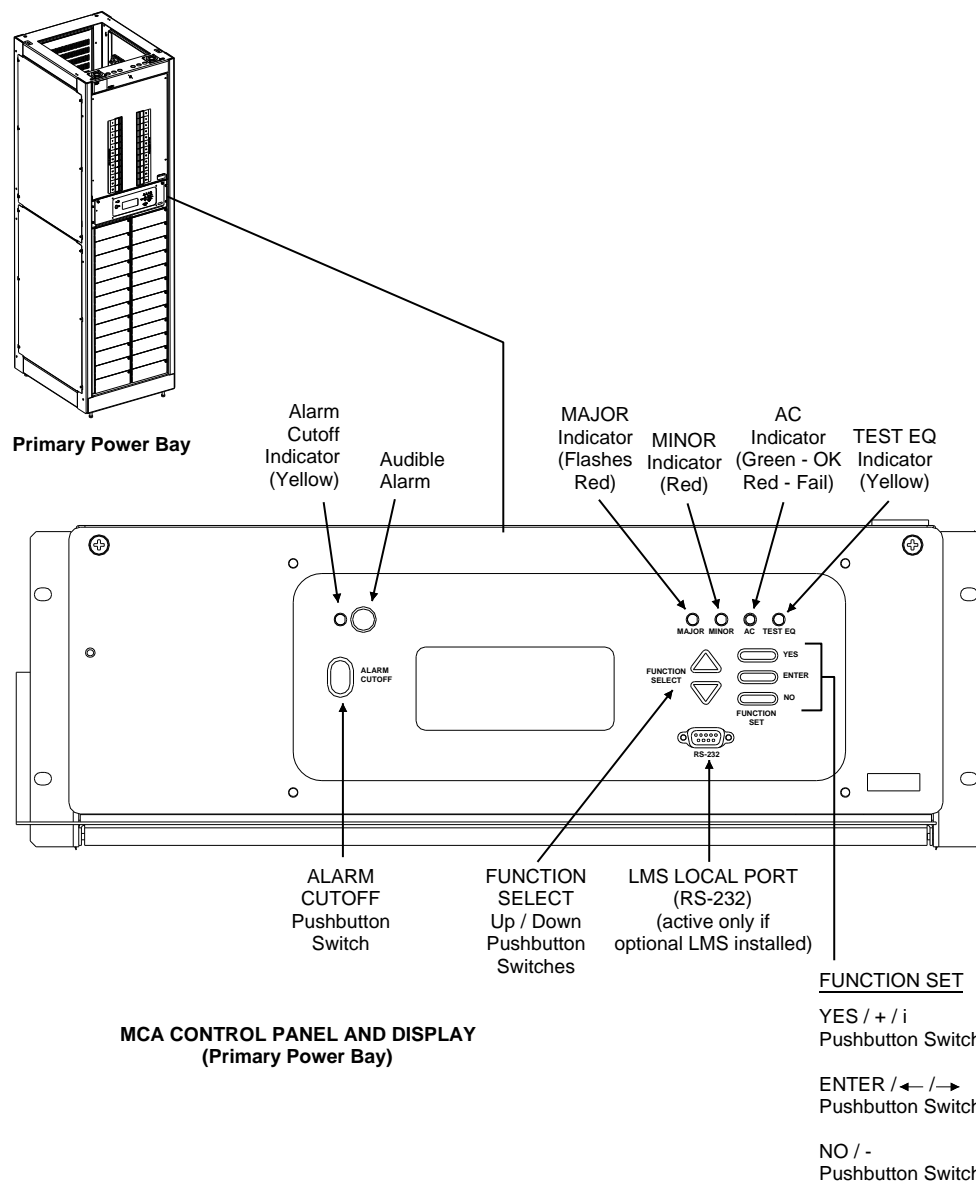

MCA Menu Tree

Section 5886 provides a color MCA Menu Tree (refer to your documentation CD).

Navigating the MCA

Navigating the MCA is an easy process. You just have to remember a few key combinations (as shown in the following chart). The symbols that appear at the end of the fourth line of the display indicate which keypad buttons can be pressed at any given time.

MCA Numbering Scheme

The MCA identifies (numbers) the components of the system as follows.

COMPONENT	MCA IDENTIFICATION NUMBER		
	MCA NUMBERING SCHEME (note that each line shown below is separated with a dash in the MCA display)	NOTES	EXAMPLE
MCA/Router	Bay #	Primary Power Bay is #1, other bays are numbered consecutively, following the bay-to-bay cabling scheme.	Primary Power Bay 1 Second Bay (Power or Distribution) 2 Fifth Bay (Power or Distribution) 5
Rectifier (PCU)	Bay # MCA Rectifier ID# within the Bay / # of Rectifiers Installed in System	Main Power Bay is #1, other bays are numbered consecutively, following the bay-to-bay cabling scheme. Rectifiers are identified from 1 to 24, as they are powered-up and recognized by the MCA.	Primary Power Bay, First Recognized Rectifier (w/ 36 rectifiers installed) 1-01/36 Second Bay, Third Recognized Rectifier (w/ 24 rectifiers installed) 2-03/24 Fifth Bay, Tenth Recognized Rectifier (w/ 12 rectifiers installed) 5-10/12
MCA Relay Circuit Card	Bay # Card Position # w/in Bay Relay # w/in Card	Primary Bay is #1, other bays are numbered consecutively, following the bay-to-bay cabling scheme. Card #1 = left slot, Card #7 = right slot. Relay # (see illustration in System Overview Section of the USER INSTRUCTIONS).	Primary Bay, Relay Card in First Slot, Relay One on Card 1-1-1 Second Bay, Relay Card in Third Slot, Relay Four on Card 2-3-4 Fifth Bay, Relay Card in Seventh Slot, Relay Six on Card 5-7-6

COMPONENT	MCA IDENTIFICATION NUMBER		
	MCA NUMBERING SCHEME (note that each line shown below is separated with a dash in the MCA display)	NOTES	EXAMPLE
MCA I/O Circuit Card	Bay # Card Position # w/in Bay	Primary Bay is #1, other bays are numbered consecutively, following the bay-to-bay cabling scheme. Card #1 = left slot, Card #7 = right slot.	Primary Bay, I/O Card in First Slot 1-1 Second Bay, I/O Card in Third Slot 2-3 Fifth Bay, I/O Card in Seventh Slot 5-7
Distribution Bay's Distribution Bus	Bay # Distribution Bus # w/in Bay (A or B Designation)	Primary Power Bay is #1, other bays are numbered consecutively, following the bay-to-bay cabling scheme. Distribution Bus #1 = Top Left, Distribution Bus #2 = Top Right, Distribution Bus #3 = Bottom Left, Distribution Bus #4 = Bottom Right, A or B as set by jumper on MCA Distribution Bus Monitoring Circuit Card.	Fifth Bay, Top Left Bus, Set for B Designation 5-1B Sixth Bay, Top Right Bus, Set for B Designation 6-2B Seventh Bay, Bottom Left Bus, Set for B Designation 7-3B Seventh Bay, Bottom Right Bus, Designation Not Set 7-4
Distribution Bay's Distribution Device	Type Bay # Distribution Point # w/in Bay	Type = Breaker or Fuse or MISC 50-73. Primary Power Bay is #1, other bays are numbered consecutively, following the bay-to-bay cabling scheme. Distribution Point = 1-12 (bottom - top, Top Left Bus, Bus #1). 13-24 (top - bottom, Top Right Bus, Bus #2). 25-36 (bottom - top, Bottom Left Bus, Bus #3). 37-48 (top - bottom, Bottom Right Bus, Bus #4). Note that distribution components may take more than one mounting position, designation number is the left most mounting position. Note: The optional bullet-device fuse panel is displayed as MISC 50-73.	Fifth Bay, Circuit Breaker Mounted in Position One, Bus 1 Set for A Designation Breaker 5-01A Sixth Bay, Fuse Mounted in Position Thirteen, Bus 2 Designation Not Set Fuse 6-13

Initial Startup Preparation

Ensure that all blocks in the "Installation Acceptance Checklist" have been checked.

Ensure all distribution fuses are removed, and all distribution circuit breakers are in the off position.

LMS Initial Startup Preparation

This procedure requires a terminal to be connected to the system, either locally (Local Port) or remotely (via the Modem Port). Refer to the separate LMS *Installation Instructions* (Section 5879) for a procedure. Section 5879 can be accessed from the CD (Electronic Documentation Package) furnished with your system.

If the local port is used, the terminal's communications parameters must be initially set for 19200 bits/s, 8 data bits, 1 stop bit, and no parity.

If the modem port is used, the terminal's communications parameters must be initially set for 8 data bits, 1 stop bit, and no parity.

Initially Starting the System

Apply DC input power to the system by closing the external DC disconnect(s) or protective device(s) that supplies battery power to the system.

Apply AC input power to the system by closing the external AC disconnect(s) or protective device(s) that supplies power to the Bay(s). There may be one or more AC disconnects or protective devices that supply power to each Bay.

If furnished, close the AC input circuit breakers located on the front of the Power Bays.

Place each distribution circuit breaker (if furnished) to the ON position and install all distribution fuses.

MCA Initialization

Whenever a system is initially started (or the MCA has been replaced), the MCA performs an initialization routine. This routine is described below.

The MCA is located in the Primary Power Bay.

Initialization Routine:

1. When power is initially applied to the system, the MCA briefly displays the MCA Software Version Number and then establishes communications with each Rectifier Module.
2. The MCA then displays CHECK VALUES BEFORE STARTING.

As you press the FUNCTION SELECT UP and DOWN arrow keys, each value listed in Table 5 is displayed. To change the setting of the currently displayed entry, press and release the ALARM CUTOFF and FUNCTION SET ENTER keys simultaneously. Line 2 of the display is replaced by "CHANGE THE VARIABLE". Use the FUNCTION SET YES (+) or NO (-) key to increase or decrease, respectively, the setting. Press the FUNCTION SET ENTER key. At the "ARE YOU SURE?" prompt, press the FUNCTION SET YES (+) key to store the new value, or the FUNCTION SET NO (-) key to cancel this operation without changing the setting. Display the next or previous entry using the FUNCTION SELECT UP or DOWN arrow key. Repeat this procedure for each entry presented.

When all the adjustable values have been properly set, press the FUNCTION SELECT DOWN arrow key until READY TO START THE SYSTEM NOW? is displayed. Press and release the ALARM CUTOFF and

FUNCTION SET ENTER keys simultaneously. At the "ARE YOU SURE?" prompt, press the FUNCTION SET YES (+) key. The MCA starts the system.

Table 5: MCA Settings

FLOAT SETPOINT = vv.vvV	Allows you to change the Float Output Voltage set point.
TEST/EQUALIZE = vv.vvV	Allows you to change the Test/Equalize Output Voltage set point.
HI VOLTAGE SHUTDOWN = vv.vvV	Allows you to change the High Voltage Shutdown set point.
PCU CURRENT LIMIT = aaaaaA or PCU CURRENT LIMIT = aaaaaMAX or PCU CURRENT LIMIT POWER SHARE or PCU CURRENT LIMIT ALT. LIMIT	Allows you to change the Current Limit set point. aaaaaA = System current limit setting, current limit circuit on all Rectifiers are automatically adjusted to ensure system current does not exceed this value. aaaaaMAX = System current limit setting is set to the sum of the maximum current capacities of all Rectifier Modules installed in the system. Note: When Power Share is enabled, current limit is controlled by the Power Share feature. Note: When Alternate Current Limit is enabled and active, current limit is controlled by the Alternate Current Limit feature.
SYSTEM HI VOLTAGE #1 = vv.vvV	Allows you to change the System High Voltage #1 Alarm set point.
SYSTEM HI VOLTAGE #2 = vv.vvV	Allows you to change the System High Voltage #2 Alarm set point.
BATTERY ON DISCHARGE = vv.vvV	Allows you to change the Battery on Discharge Alarm set point.
VERY LOW VOLTAGE = vv.vvV	Allows you to change the Very Low Voltage Alarm set point.
TOTAL DISTRIBUTION = aaaaaA	Allows you to change the Total Distribution Load Current Alarm set point.
DISTRIBUTION GROUP A = aaaaaA	Allows you to change the Distribution Group A Load Current Alarm set point.
DISTRIBUTION GROUP B = aaaaaA	Allows you to change the Distribution Group B Load Current Alarm set point.

<p>HIGH TEMPERATURE #1 = ttt°C/F or NO HIGH TEMPERATURE #1 ALARM</p>	<p>Allows you to change the High Temperature #1 Alarm set point, or disable the alarm. Note: To disable the feature, press YES / + / i when in the change setting mode to scroll to NO HIGH TEMPERATURE #1 ALARM (displayed when you scroll up to "100°C").</p>
<p>HIGH TEMPERATURE #2 = ttt°C/F or NO HIGH TEMPERATURE #2 ALARM</p>	<p>Allows you to change the High Temperature #2 Alarm set point, or disable the alarm. Note: To disable the feature, press YES / + / i when in the change setting mode to scroll to NO HIGH TEMPERATURE #2 ALARM (displayed when you scroll up to "100°C").</p>
<p>LOW TEMPERATURE #1 = ttt°C/F or NO LOW TEMPERATURE #1 ALARM</p>	<p>Allows you to change the Low Temperature #1 Alarm set point, or disable the alarm. Note: To disable the feature, press NO / - when in the change setting mode to scroll to NO LOW TEMPERATURE #1 ALARM (displayed when you scroll down to "-50°C").</p>
<p>LOW TEMPERATURE #2 = ttt°C/F or NO LOW TEMPERATURE #2 ALARM</p>	<p>Allows you to change the Low Temperature #2 Alarm set point, or disable the alarm. Note: To disable the feature, press NO / - when in the change setting mode to scroll to NO LOW TEMPERATURE #2 ALARM (displayed when you scroll down to "-50°C").</p>
<p>AUDIBLE SILENT TIME = mm MINUTES or AUDIBLE ALARMS STAY SILENCED</p>	<p>Allows you to enable the MCA Audible Alarm feature and set the Audible Alarm Cutoff Reset Time Period set point, or disable the feature. Note: To disable the feature, press NO / - when in the change setting mode to scroll to AUDIBLE ALARMS STAY SILENCED (displayed when you scroll down to "zero minutes").</p>

<p>PCU SEQUENCING IS DISABLED</p> <p>or</p> <p>PCU SEQUENCING DELAY = ss SECONDS</p>	<p>Allows you to enable the Rectifier Module Sequencing feature and set the PCU Sequencing Delay set point, or disable the feature.</p> <p>Note: To disable the feature, press NO / - when in the change setting mode to scroll to PCU SEQUENCING IS DISABLED (displayed when you scroll down to "zero seconds").</p>
<p>TEST EQUALIZE IS DISABLED TURN OFF POWER SHARE</p> <p>or</p> <p>MANUAL TEST/EQUALIZE = hh HOURS</p> <p>or</p> <p>TEST/EQUALIZE STOP IS MANUAL</p>	<p>Allows you to enable the Manual Timed Test/Equalize feature and set the Timed Test/Equalize set point, or disable the feature.</p> <p>Note: To disable the feature, press NO / - when in the change setting mode to scroll to TEST/EQUALIZE STOP IS MANUAL (displayed when you scroll down to "zero hours"). This indicates the manually initiated timed test/equalize feature is disabled and the system must be manually returned to the float mode if placed in the test/equalize mode.</p> <p>When the Power Share feature is enabled, the system cannot be placed in the Test/Equalize mode.</p> <p>Note: Test/Equalize Mode requires Power Share to be turned off. A message is displayed if Power Share is on.</p>
<p>AUTO EQUALIZE IS DISABLED</p> <p>or</p> <p>TURN OFF POWER SHARE</p> <p>or</p> <p>AUTO EQUALIZE FOR ## x DISCHARGE</p>	<p>Allows you to enable the Auto Test/Equalize feature and set the Auto Test/Equalize Multiplier set point, or disable the feature.</p> <p>Note: To disable the feature, press NO / - when in the change setting mode to scroll to AUTO EQUALIZE IS DISABLED (displayed when you scroll down to "zero x discharge").</p> <p>When the Power Share feature is enabled, the system cannot be placed in the Test/Equalize mode.</p> <p>Note: Test/Equalize Mode requires Power Share to be turned off. A message is displayed if Power Share is on.</p>

<p>NO TEMPERATURE COMPENSATION or TURN OFF POWER SHARE or TEMPERATURE SLOPE = 0.vvvV/°C/F</p>	<p>Allows you to enable the Battery Charge Temperature Compensation feature and set the Battery Charge Temperature Compensation Slope set point, or disable the feature.</p> <p>Note: To disable the feature, press NO / - when in the change setting mode to scroll to NO TEMPERATURE COMPENSATION (displayed when you scroll down to "OV / °~").</p> <p>Note: This is the voltage slope of the entire battery string, not individual cells.</p> <p>Note: The Temperature Compensation feature requires Power Share to be turned off. A message is displayed if Power Share is on.</p> <p>Note: The LMS has a Power System Remote Temperature Compensation feature. Refer to the LMS Installation Manual (Section 5879) for programming information.</p>
<p>MAXIMUM COMPENSATION = vv.vvV</p>	<p>Allows you to change the Maximum Voltage with Temperature Compensation set point.</p>
<p>MINIMUM COMPENSATION = vv.vvV</p>	<p>Allows you to change the Minimum Voltage with Temperature Compensation set point.</p>
<p>IT IS NOW hh:mm:ss dd-mon-yy</p>	<p>Allows you to change the time and date.</p>
<p>READY TO START THE SYSTEM NOW?</p>	<p>Allows you to start the system with the selected settings.</p> <ol style="list-style-type: none"> 1. Press ENTER and ALARM CUTOFF (at the same time). 2. At the "ARE YOU SURE?" prompt, press YES / + / i.

Checking the Inventory and Setting the Number of PCU (Rectifier) Positions Available in the System

Procedure:

1. With SYSTEM OK being displayed on the MCA Interface Pad, press and release the FUNCTION SET ENTER key.
2. Repeatedly press and release the FUNCTION SELECT DOWN arrow key until VIEW THE SYSTEM INVENTORY is displayed.

3. Press and release the FUNCTION SET ENTER key.
4. Repeatedly press and release the FUNCTION SELECT DOWN arrow key until ## PCU POSITIONS ARE EMPTY is displayed.
5. Press and release the ALARM CUTOFF and FUNCTION SET ENTER keys simultaneously. Line 2 of the display is replaced by "CHANGE THE VARIABLE".



NOTE! *There is a 20 second timeout. If the MCA times out, press ALARM CUTOFF and FUNCTION SET ENTER again.*

6. Press and hold the FUNCTION SET YES (+) or NO (-) key to set the number of PCU (Rectifier) positions available in the system (empty and filled). Release the key when the desired value is displayed.
7. With the desired value being displayed, press and release the FUNCTION SET ENTER key.
8. "ARE YOU SURE?" is displayed. Press and release the FUNCTION SET YES (+) key.
9. Scroll up and down through the remaining Inventory Items using the FUNCTION SELECT UP and DOWN arrow keys. Verify that the Inventory Items are correct for your system.
10. When done, press and release the FUNCTION SET YES (+) and NO (-) keys simultaneously, to return to the beginning of the MCA menu tree.

Mapping PCU (Rectifier) Location

When all PCUs (rectifiers) are installed prior to applying power and starting the system, the MCA randomly assigns a position ID to each PCU in each bay.

If you prefer the MCA to identify the PCUs by specific position in each bay, perform the following procedure.

Procedure

1. With SYSTEM OK being displayed on the MCA Interface Pad, press and release the FUNCTION SET ENTER key.
2. Repeatedly press and release the FUNCTION SELECT DOWN arrow key until CHANGE CONFIGURATION PARAMETERS is displayed.
3. Press and release the FUNCTION SET ENTER key.
4. Repeatedly press and release the FUNCTION SELECT DOWN arrow key until ARRANGE PCU ORDER is displayed.
5. Press and release the FUNCTION SET ENTER key.
6. BAY ## is displayed. Press the FUNCTION SELECT UP or DOWN arrow keys to select the bay you wish to map.
7. Press and release the FUNCTION SET ENTER key. The existing position ID along with the PCU serial number is displayed, and the green POWER indicator on the PCU flashes for physical identification.
8. Press the FUNCTION SELECT UP or DOWN arrow keys to navigate to the PCU you wish to remap.
9. Press and release the ALARM CUTOFF and FUNCTION SET ENTER keys simultaneously to select the PCU.

10. Press FUNCTION SET YES (+) and NO (-) keys change the position ID of the PCU.
11. Press the ENTER key to bookmark the new PCU position ID.
12. "ARE YOU SURE?" is displayed. Press and release the FUNCTION SET YES (+) key.
13. Repeat Steps 8 through 12 for the remaining PCUs in the bay.
14. When the last PCU in the bay has been mapped, the MCA will display "SAVE PCU MAPPING" if no conflicts are detected. (Note: If a conflict is detected, the MCA will display "DUPLICATED MAPPING DETECTED". If this message is displayed, pressing the FUNCTION SELECT UP arrow key will return you to the PCU mapping menu.)
15. Press and release the ALARM CUTOFF and FUNCTION SET ENTER keys simultaneously.
16. "ARE YOU SURE?" is displayed. Press and release the FUNCTION SET YES (+) key. (Note: The PCU mapping will be automatically saved when the save timer expires.)
17. Repeat Steps 5 through 16 for the remaining bays.



NOTE! When empty slots exist between mapped PCUs, newly inserted PCUs must be mapped manually. Not manually mapping PCUs may cause a PCU to be assigned an invalid slot number (displayed as "--").

Setting the Date and Time

Procedure:

1. With SYSTEM OK being displayed on the MCA Interface Pad, press and release the FUNCTION SET ENTER key.
2. Repeatedly press and release the FUNCTION SELECT DOWN arrow key until CHANGE CONFIGURATION PARAMETERS is displayed.
3. Press and release the FUNCTION SET ENTER key.
4. Repeatedly press and release the FUNCTION SELECT DOWN arrow key until IT IS NOW hh.mm.ss dd-mon-yy is displayed.
5. Press and release the ALARM CUTOFF and FUNCTION SET ENTER keys simultaneously. The day of the month is underlined.
6. Press FUNCTION SET YES (+) and NO (-) keys to change the day of month.
7. Press FUNCTION SET ENTER key. Month is underlined.
8. Press FUNCTION SET YES (+) and NO (-) keys to change the month.
9. Press FUNCTION SET ENTER key. Year is underlined.
10. Press FUNCTION SET YES (+) and NO (-) keys to change the year.
11. Press FUNCTION SET ENTER key. Hour is underlined.
12. Press FUNCTION SET YES (+) and NO (-) keys to change the hour.
13. Press FUNCTION SET ENTER key. Minutes is underlined.
14. Press FUNCTION SET YES (+) and NO (-) keys to change the minutes.

15. Press FUNCTION SET ENTER key.

Setting the Temperature Units (Degrees C or Degrees F)

Procedure:

1. With SYSTEM OK being displayed on the MCA Interface Pad, press and release the FUNCTION SET ENTER key.
2. Repeatedly press and release the FUNCTION SELECT DOWN arrow key until CHANGE CONFIGURATION PARAMETERS is displayed.
3. Press and release the FUNCTION SET ENTER key.
4. Repeatedly press and release the FUNCTION SELECT DOWN arrow key until NOW DISPLAYING C/F SET TO C/F? is displayed (C/F = C or F is displayed).
5. Press and release the ALARM CUTOFF and FUNCTION SET ENTER keys simultaneously.
6. "ARE YOU SURE?" is displayed. Press and release the FUNCTION SET YES (+) key.
7. Press and release the FUNCTION SET YES (+) and NO (-) keys simultaneously, to return to the beginning of the MCA menu tree.

Setting and Testing MCA Customer Alarm Relays (and MCA Relay Function Channels)

Setting Relay Functions

 **NOTE!** DO NOT set relay functions if you are using the default MCA configuration. See Table 1 for the default configuration.

 **NOTE!** MCA Relay Function Channel #24 also sets which conditions are recorded in the MCA Alarm Log as Controller Alarms.

Procedure:

1. With SYSTEM OK being displayed on the MCA Interface Pad, press and release the FUNCTION SET ENTER key.
2. Repeatedly press and release the FUNCTION SELECT DOWN arrow key until CHANGE CONFIGURATION PARAMETERS is displayed.
3. Press and release the FUNCTION SET ENTER key.
4. Repeatedly press and release the FUNCTION SELECT DOWN arrow key until DEFINE RELAY FUNCTIONS is displayed.
5. Press and release the FUNCTION SET ENTER key.
6. DEFINE RELAY FUNCTION A# is displayed. Press and release the FUNCTION SELECT DOWN and UP arrow keys to select the Relay Function Channel to be defined.
7. Press and release the FUNCTION SET ENTER key.
8. CHECKED CONDITIONS DE-ENERGIZED or ENERGIZED is displayed.

Select whether the relay(s) assigned to this Relay Function Channel will energize or deenergize for any condition checked (selected) next.

To change the setting, press and release the ALARM CUTOFF and FUNCTION SET ENTER keys simultaneously. “ARE YOU SURE?” is displayed. Press and release the FUNCTION SET YES (+) key.

9. Press and release the FUNCTION SELECT DOWN and UP arrow keys to select the alarm conditions for this Relay Function Channel. A checkmark appears next to conditions selected, a space appears next to conditions not selected.

To change the setting, press and release the ALARM CUTOFF and FUNCTION SET ENTER keys simultaneously. “ARE YOU SURE?” is displayed. Press and release the FUNCTION SET YES (+) key.

10. When done, navigate to GO TO RELAY FUNCTION MENU in the RELAY FUNCTION DEFINITION MENU. Press and release the FUNCTION SET ENTER key.
11. In the RELAY FUNCTION MENU, press and release the FUNCTION SELECT DOWN and UP arrow keys to select another Relay Function Channel to be defined.
12. Repeat the above steps to configure all Relay Function Channels.
13. When done, navigate to GO TO CONFIGURE MENU in the RELAY FUNCTION MENU. Press and release the FUNCTION SET ENTER key.
14. Go to the next procedure.

Setting Relay Assignments

 **NOTE!** DO NOT set relay assignments if you are using the default MCA configuration. See **Table 1** for the default configuration.

Procedure:

1. In the CONFIGURE MENU, repeatedly press and release the FUNCTION SELECT DOWN arrow key until ASSIGN RELAYS TO FUNCTIONS is displayed.
2. Press and release the FUNCTION SET ENTER key.
3. ASSIGN RELAY B#-P#-R# FUNCTION A# is displayed. Repeatedly press and release the FUNCTION SELECT DOWN and UP arrow keys to select the MCA Customer Alarm Relay to assign a Relay Function to. (B#-P#-R# = Bay Number-MCA Customer Alarm Relay Circuit Card Position Number-Relay on Card Number)
4. Press and release the ALARM CUTOFF and FUNCTION SET ENTER keys simultaneously.
5. Press the FUNCTION SELECT UP and DOWN arrow keys to select the desired Relay Function Number.
6. Press and release the FUNCTION SET ENTER key.
7. “ARE YOU SURE?” is displayed. Press and release the FUNCTION SET YES (+) key.
8. Press and release the FUNCTION SET YES (+) and NO (-) keys simultaneously, to return to the beginning of the MCA menu tree.

Testing Relays

Procedure:

1. With SYSTEM OK being displayed on the MCA Interface Pad, press and release the FUNCTION SET ENTER key.
2. Repeatedly press and release the FUNCTION SELECT DOWN arrow key until CHANGE CONFIGURATION PARAMETERS is displayed.
3. Press and release the FUNCTION SET ENTER key.
4. Repeatedly press and release the FUNCTION SELECT DOWN arrow key until START RELAY FUNCTION TEST is displayed.
5. Press and release the ALARM CUTOFF and FUNCTION SET ENTER keys simultaneously.
6. TIME PER FUNCTION = hh:mm:ss is displayed. Repeatedly press and release the FUNCTION SELECT DOWN and UP arrow keys to select a time period for each Relay Function Channel test or to display TIME PER FUNCTION NO TIMEOUT.
7. Press and release the FUNCTION SET ENTER key.
8. Press the UP and DOWN ARROW keys to select either AUTOMATICALLY TEST ALL FUNCTIONS (to test all Relay Function Channels) or TEST RELAY FUNCTION A# (to test an individual Relay Function Channel).
9. Press and release the FUNCTION SET ENTER key.
10. "ARE YOU SURE?" is displayed. Press and release the FUNCTION SET YES (+) key.
11. The Relay Function being tested and the remaining time are displayed. Check your external alarms for proper operation.
12. To terminate the test, press and release the ALARM CUTOFF and FUNCTION SET ENTER keys simultaneously until STOP RELAY FUNCTION TEST is displayed.
13. "ARE YOU SURE?" is displayed. Press and release the FUNCTION SET YES (+) key.

Setting MCA I/O Circuit Card Parameters

Procedure:

1. With SYSTEM OK being displayed on the MCA Interface Pad, press and release the FUNCTION SET ENTER key.
2. Repeatedly press and release the FUNCTION SELECT DOWN arrow key until CHANGE CONFIGURATION PARAMETERS is displayed.
3. Press and release the FUNCTION SET ENTER key.
4. CHANGE I/O BOARD PARAMETERS is displayed. Press and release the FUNCTION SET ENTER key.
5. Navigate the I/O BOARD CONFIGURATION MENU to set...
any analog input to show up in the DISTRIBUTION or AUXILIARY menus,
any analog input scale factor,
any analog output scale factor,
any binary input alarm state (open or close).

 **NOTE!** If a binary input alarms, the MCA displays a "Binary Input Customer Text Message" in the I/O Board Alarm Detail Message. If you wish to change the default message, refer to the "SYSTEM OPERATING PROCEDURES" section in Section 6017.

6. Press and release the FUNCTION SET YES (+) and NO (-) keys simultaneously, to return to the beginning of the MCA menu tree.

Checking Manual Test/Equalize and Manually Initiated Timed Test/Equalize

 **NOTE!** Test/Equalize Mode requires Power Share to be turned off.

Procedure:

1. With SYSTEM OK being displayed on the MCA Interface Pad, press and release the FUNCTION SET ENTER key.
2. Repeatedly press and release the FUNCTION SELECT DOWN arrow key until CHANGE CONFIGURATION PARAMETERS is displayed.
3. Press and release the FUNCTION SET ENTER key.
4. Repeatedly press and release the FUNCTION SELECT DOWN arrow key until MANUAL TEST/EQUALIZE = hh HOURS or TEST/EQUALIZE STOP IS MANUAL is displayed. If MANUAL TEST/EQUALIZE = hh HOURS is displayed, perform steps 5) through 9). If TEST/EQUALIZE STOP IS MANUAL is displayed, go to step 10).
5. Record the value indicated on the display.
6. Press and release the ALARM CUTOFF and FUNCTION SET ENTER keys simultaneously. Line 2 of the display is replaced by "CHANGE THE VARIABLE".
7. Press the FUNCTION SET YES (+) key until the value displayed increases above 99, then release the key.
 - a) **Requirement:** TEST/EQUALIZE STOP IS MANUAL is displayed.
8. Press and release the FUNCTION SET ENTER key.
9. "ARE YOU SURE?" is displayed. Press and release the FUNCTION SET YES (+) key.
10. Press and release the FUNCTION SET YES (+) and NO (-) keys simultaneously, to return to the beginning of the MCA menu tree.
11. Press and release the FUNCTION SET ENTER key.
12. Press and release the FUNCTION SELECT DOWN arrow key to display FLOAT MODE IS ACTIVE SET TEST/EQ?.
13. Press and release the ALARM CUTOFF and FUNCTION SET ENTER keys simultaneously.
14. "ARE YOU SURE?" is displayed. Press and release the FUNCTION SET YES (+) key.
 - a) **Requirement:** System output voltage goes to the test/equalize setting.
 - b) **Requirement:** MCA TEST/EQ indicator goes yellow.

- c) **Requirement:** External test/equalize alarms activate (if configured).
- 15. Press and release the FUNCTION SET YES (+) and NO (-) keys simultaneously, to return to the beginning of the MCA menu tree.
- 16. Press and release the FUNCTION SET ENTER key.
- 17. Press and release the FUNCTION SELECT DOWN arrow key to display TEST/EQ MODE IS ACTIVE SET FLOAT?.
- 18. Press and release the ALARM CUTOFF and FUNCTION SET ENTER keys simultaneously.
- 19. "ARE YOU SURE?" is displayed. Press and release the FUNCTION SET YES (+) key.
 - a) **Requirement:** System output voltage goes to the float setting.
 - b) **Requirement:** MCA TEST/EQ indicator goes out.
 - c) **Requirement:** External test/equalize alarms reset (if configured).



NOTE! *The following portion of this procedure takes one hour to complete. If you do not want to continue with this procedure, go to step 32).*

- 20. Repeatedly press and release the FUNCTION SELECT DOWN arrow key until CHANGE CONFIGURATION PARAMETERS is displayed.
- 21. Press and release the FUNCTION SET ENTER key.
- 22. Repeatedly press and release the FUNCTION SELECT DOWN arrow key until TEST/EQUALIZE STOP IS MANUAL is displayed.
- 23. Press and release the ALARM CUTOFF and FUNCTION SET ENTER keys simultaneously. Line 2 of the display is replaced by "CHANGE THE VARIABLE".
- 24. Press the FUNCTION SET NO (-) key until the value displayed is decreased to 1, then release the key.
- 25. Press and release the ALARM CUTOFF and FUNCTION SET ENTER keys simultaneously.
- 26. "ARE YOU SURE?" is displayed. Press and release the FUNCTION SET YES (+) key.
- 27. Press and release the FUNCTION SET YES (+) and NO (-) keys simultaneously, to return to the beginning of the MCA menu tree.
- 28. Press and release the FUNCTION SET ENTER key.
- 29. Press and release the FUNCTION SELECT DOWN arrow key to display FLOAT MODE IS ACTIVE SET TEST/EQ.
- 30. Press and release the ALARM CUTOFF and FUNCTION SET ENTER keys simultaneously.
- 31. "ARE YOU SURE?" is displayed. Press and release the FUNCTION SET YES (+) key.
 - a) **Requirement:** System output voltage goes to the test/equalize setting.
 - b) **Requirement:** MCA TEST/EQ indicator goes yellow.
 - c) **Requirement:** External test/equalize alarms activate (if configured).

- d) **Requirement:** In one hour, the following occurs ...
- **Requirement:** System output voltage goes to the float setting.
 - **Requirement:** MCA TEST/EQ indicator goes out.
 - **Requirement:** External test/equalize alarms reset (if configured).
32. Press and release the FUNCTION SET YES (+) and NO (-) keys simultaneously, to return to the beginning of the MCA menu tree.
 33. Press and release the FUNCTION SET ENTER key.
 34. Repeatedly press and release the FUNCTION SELECT DOWN arrow key until CHANGE CONFIGURATION PARAMETERS is displayed.
 35. Press and release the FUNCTION SET ENTER key.
 36. Repeatedly press and release the FUNCTION SELECT DOWN arrow key until MANUAL TEST/EQUALIZE = hh HOURS is displayed.
 37. Press and release the ALARM CUTOFF and FUNCTION SET ENTER keys simultaneously. Line 2 of the display is replaced by "CHANGE THE VARIABLE".
 38. Press the FUNCTION SET YES (+) key until the value displayed increases to the value recorded in step 5), then release the key. If TEST/EQUALIZE STOP IS MANUAL was being displayed in step 5), press the FUNCTION SET YES (+) key until the value displayed increases above 99.
 39. Press and release the FUNCTION SET ENTER key.
 40. "ARE YOU SURE?" is displayed. Press and release the FUNCTION SET YES (+) key.
 41. Press and release the FUNCTION SET YES (+) and NO (-) keys simultaneously, to return to the beginning of the MCA menu tree.

Checking Remote High Voltage Shutdown and Rectifier Module Emergency Shutdown (ESTOP) Inputs

The Remote High Voltage Shutdown and Rectifier Module Emergency Shutdown (ESTOP) circuits can be tested without affecting the system by applying a Test loop closure between terminals 7 and 8 of TB1 located on the MCA circuit card before applying the Remote High Voltage Shutdown or Rectifier Module Emergency Shutdown loop closure signal. Removal of the Test loop closure signal enables normal operation of the Remote High Voltage Shutdown and Rectifier Module Emergency Shutdown circuits.

Procedure:

1. With SYSTEM OK being displayed on the MCA Interface Pad, press and release the FUNCTION SET ENTER key.
2. Repeatedly press and release the FUNCTION SELECT DOWN arrow key until VERIFY TEST, ESTOP,& HVS INPUTS is displayed.
3. Apply the Test loop closure.
 - a) **Requirement:** Verify MCA displays TEST SHUTDOWN INPUT IS ON.
4. With the Test loop closure still applied, apply the Emergency Stop loop closure.

- a) **Requirement:** Verify MCA displays EMERGENCY STOP INPUT IS ON.
- 5. Release the Emergency Stop loop closure.
- 6. With the Test loop closure still applied, apply the High Voltage Shutdown loop closure.
 - a) **Requirement:** Verify MCA displays HI VOLTAGE SHUTDOWN INPUT IS ON.
- 7. Release the High Voltage Shutdown loop closure.
- 8. Release the Test loop closure.
- 9. Press and release the FUNCTION SET YES (+) and NO (-) keys simultaneously, to return to the beginning of the MCA menu tree.

Checking Remote High Voltage Shutdown



ALERT! This procedure may interrupt power to the load. Perform this test only during system initial startup and checkout, or when a load is not connected to the system.

Procedure:

1. Apply and remove a remote high voltage shutdown signal to the system.
 - a) **Requirement:** The high voltage shutdown circuit on all Rectifier Modules activates to shut down the Rectifier Modules. After approximately four seconds, the restart circuit is automatically activated to restore Rectifier Module operation.
 - b) **Requirement:** All Rectifier Module "Rectifier Module FAIL" indicators go red while the Rectifier Modules are shut down.
 - c) **Requirement:** MCA "MAJOR" indicator flashes red while the Rectifier Modules are shut down, if battery is connected to the system.
 - d) **Requirement:** MCA displays HI VOLTAGE SHUTDOWN INPUT ACTIVE and ### Rectifier Modules HAVE FAILED while the Rectifier Modules are shut down, if battery is connected to the system.
 - e) **Requirement:** External alarms activate (if configured) while the Rectifier Modules are shut down.

Checking Emergency Shutdown and Fire Alarm Disconnect



ALERT! This procedure may interrupt power to the load. Perform this test only during system initial startup and checkout, or when a load is not connected to the system.

Procedure:

1. Apply an emergency shutdown and fire alarm disconnect signal to the system.
 - a) **Requirement:** The Rectifier Modules inhibit.
 - b) **Requirement:** MCA "MAJOR" indicator flashes red, if battery is connected to the system.
 - c) **Requirement:** MCA displays EMERGENCY STOP INPUT ACTIVE and ### Rectifier Modules HAVE FAILED, if battery is connected to the system.
 - d) **Requirement:** External alarms activate (if configured).

2. Remove the emergency shutdown and fire alarm disconnect signal from the system. Turn AC power to the Rectifier Modules off then on, or remove and re-insert the Rectifier Modules.
 - a) **Requirement:** The Rectifier Modules are restored.
 - b) **Requirement:** MCA “MAJOR” indicator goes out.
 - c) **Requirement:** MCA displays SYSTEM OK message.
 - d) **Requirement:** External alarms reset (if configured).

Checking Remote Test/Equalize



NOTE! *Test/Equalize Mode requires Power Share to be turned off.*

Procedure:

1. Apply a remote test/equalize signal to the system.
 - a) **Requirement:** System output voltage goes to the test/equalize setting.
 - b) **Requirement:** MCA TEST/EQ indicator goes yellow.
 - c) **Requirement:** External test/equalize alarms activate (if configured).
2. Remove the remote test/equalize signal from the system.
 - a) **Requirement:** System output voltage goes to the float setting.
 - b) **Requirement:** MCA TEST/EQ indicator goes out.
 - c) **Requirement:** External test/equalize alarms reset (if configured).

Checking MCA Audible Alarm and MCA Audible Alarm Cutoff

Procedure:

1. Open one of the AC input circuit breakers that supplies power to the Rectifier Modules (if furnished), or open the external AC disconnect or protective device that supplies power to one or more of the Rectifier Modules.
 - a) **Requirement:** External MCA audible alarm sounds.
 - b) **Requirement:** Other alarms activate. Disregard them here. They will be confirmed in a later check.
2. Press and release the ALARM CUTOFF key.
 - a) **Requirement:** External MCA audible alarm silences.
 - b) **Requirement:** MCA ALARM CUTOFF indicator goes yellow.
3. Wait the pre-programmed MCA audible alarm cutoff reset time interval (if set).
 - a) **Requirement:** External MCA audible alarm again sounds.
 - b) **Requirement:** MCA ALARM CUTOFF indicator goes out.

4. Return the external AC disconnect, protective device, or internal AC input circuit breaker to the ON position.
 - a) **Requirement:** External MCA audible alarm silences.

Checking AC Fail Alarm and Rectifier Module Fail Alarm

Procedure:

1. Open one of the AC input circuit breakers that supplies power to the Rectifier Modules (if furnished), or open the external AC disconnect or protective device that supplies power to one or more of the Rectifier Modules.
 - a) **Requirement:** Rectifier Module “Power” indicator goes out.
 - b) **Requirement:** Rectifier Module “Protection” indicator goes yellow.
 - c) **Requirement:** MCA “AC” indicator goes red.
 - d) **Requirement:** MCA “MINOR” indicator goes red (power removed from one Rectifier Module), or MCA “MAJOR” indicator flashes red (power removed from more than one Rectifier Module).



NOTE! *If there is only one Rectifier Module installed, the “MAJOR” indicator flashes red.*

- e) **Requirement:** MCA displays 1 (or more) Rectifier Module HAS FAILED.
 - f) **Requirement:** External alarms activate (if configured).
2. Open a second AC input circuit breaker that supplies power to the Rectifier Modules, or open the external AC disconnect or protective device that supplies power to a second Rectifier Module (individual Rectifier Module feeds only).
 - a) **Requirement:** Rectifier Module “Power” indicator goes out.
 - b) **Requirement:** Rectifier Module “Protection” indicator goes yellow.
 - c) **Requirement:** MCA “MINOR” indicator goes out.
 - d) **Requirement:** MCA “MAJOR” indicator flashes red.
 - e) **Requirement:** MCA displays 2 Rectifier Modules HAVE FAILED.
 - f) **Requirement:** External alarms activate (if configured).
3. Return both external AC disconnects, protective devices, or internal AC input circuit breakers to the ON position.
 - a) **Requirement:** Rectifier Module “Power” indicators on both Rectifier Modules go green.
 - b) **Requirement:** Rectifier Module “Protection” indicators on both Rectifier Modules go out.
 - c) **Requirement:** MCA “MAJOR” indicator goes out.
 - d) **Requirement:** MCA displays SYSTEM OK message.
 - e) **Requirement:** External alarms reset (if configured).

Checking System High Voltage Alarm 1

Procedure:

1. With "SYSTEM OK" being displayed on the MCA Interface Pad, press and release the FUNCTION SET ENTER key.
2. Repeatedly press and release the FUNCTION SELECT DOWN arrow key until ADJUST THE ALARM SETPOINTS is displayed.
3. Press and release the FUNCTION SET ENTER key.
4. SYSTEM HI VOLTAGE #1 = vv.vvV is displayed.
5. Record the value indicated on the display.
6. Press and release the ALARM CUTOFF and FUNCTION SET ENTER keys simultaneously. Line 2 of the display is replaced by "CHANGE THE VARIABLE".
7. Press the FUNCTION SET NO (-) key until the value displayed is decreased to below system voltage level, then release the key.
8. Press and release the FUNCTION SET ENTER key.
9. "ARE YOU SURE?" is displayed. Press and release the FUNCTION SET YES (+) key.
 - a) **Requirement:** MCA "MAJOR" indicator flashes red.
 - b) **Requirement:** MCA displays a SYSTEM HIGH VOLTAGE #1 ALARM message.
 - c) **Requirement:** External alarms activate (if configured).
10. With SYSTEM HIGH VOLTAGE #1 ALARM being displayed in the ALARM ADJUSTMENT MENU, press and release the ALARM CUTOFF and FUNCTION SET ENTER keys simultaneously.
11. Press the FUNCTION SET YES (+) key until the value displayed is increased to the value recorded in step 5) or to the required value for your site, then release the key.
12. Press and release the FUNCTION SET ENTER key.
13. "ARE YOU SURE?" is displayed. Press and release the FUNCTION SET YES (+) key.
 - a) **Requirement:** MCA "MAJOR" indicator goes out.
 - b) **Requirement:** External alarms reset (if configured).
14. Press and release the FUNCTION SET YES (+) and NO (-) keys simultaneously, to return to the beginning of the MCA menu tree.

Checking System High Voltage Alarm 2

Procedure:

1. With "SYSTEM OK" being displayed on the MCA Interface Pad, press and release the FUNCTION SET ENTER key.
2. Repeatedly press and release the FUNCTION SELECT DOWN arrow key until ADJUST THE ALARM SETPOINTS is displayed.

3. Press and release the FUNCTION SET ENTER key.
4. Press and release the FUNCTION SELECT DOWN arrow key to display SYSTEM HI VOLTAGE #2 = vv.vvV.
5. Record the value indicated on the display.
6. Press and release the ALARM CUTOFF and FUNCTION SET ENTER keys simultaneously. Line 2 of the display is replaced by "CHANGE THE VARIABLE".
7. Press the FUNCTION SET NO (-) key until the value displayed is decreased to below system voltage level, then release the key.
8. Press and release the FUNCTION SET ENTER key.
9. "ARE YOU SURE?" is displayed. Press and release the FUNCTION SET YES (+) key.
 - a) **Requirement:** MCA "MAJOR" indicator flashes red.
 - b) **Requirement:** MCA displays a SYSTEM HIGH VOLTAGE #2 ALARM message.
 - c) **Requirement:** External alarms activate (if configured).
10. With SYSTEM HIGH VOLTAGE #2 ALARM being display in the ALARM ADJUSTMENT MENU, press and release the ALARM CUTOFF and FUNCTION SET ENTER keys simultaneously.
11. Press the FUNCTION SET YES (+) key until the value displayed is increased to the value recorded in step 5) or to the required value for your site, then release the key.
12. Press and release the FUNCTION SET ENTER key.
13. "ARE YOU SURE?" is displayed. Press and release the FUNCTION SET YES (+) key.
 - a) **Requirement:** MCA "MAJOR" indicator goes out.
 - b) **Requirement:** External alarms reset (if configured).
14. Press and release the FUNCTION SET YES (+) and NO (-) keys simultaneously, to return to the beginning of the MCA menu tree.

Checking System Battery Is On Discharge Alarm

Procedure:

1. With "SYSTEM OK" being displayed on the MCA Interface Pad, press and release the FUNCTION SET ENTER key.
2. Repeatedly press and release the FUNCTION SELECT DOWN arrow key until ADJUST THE ALARM SETPOINTS is displayed.
3. Press and release the FUNCTION SET ENTER key.
4. Repeatedly press and release the FUNCTION SELECT DOWN arrow key until BATTERY ON DISCHARGE = vv.vvV is displayed.
5. Record the value indicated on the display.

6. Press and release the ALARM CUTOFF and FUNCTION SET ENTER keys simultaneously. Line 2 of the display is replaced by "CHANGE THE VARIABLE".
7. Press the FUNCTION SET YES (+) key until the value displayed is increased to above system voltage level, then release the key.
8. Press and release the FUNCTION SET ENTER key.
9. "ARE YOU SURE?" is displayed. Press and release the FUNCTION SET YES (+) key.
 - a) **Requirement:** MCA "MAJOR" indicator flashes red.
 - b) **Requirement:** MCA displays SYSTEM BATTERY IS ON DISCHARGE.
 - c) **Requirement:** External alarms activate (if configured).
10. With BATTERY ON DISCHARGE =- vv.vvV being displayed in the ALARM ADJUSTMENT MENU, press and release the ALARM CUTOFF and FUNCTION SET ENTER keys simultaneously.
11. Press the FUNCTION SET NO (-) key until the value displayed is decreased to the value recorded in step 5) or to the required value for your site, then release the key.
12. Press and release the FUNCTION SET ENTER key.
13. "ARE YOU SURE?" is displayed. Press and release the FUNCTION SET YES (+) key.
 - a) **Requirement:** MCA "MAJOR" indicator goes out.
 - b) **Requirement:** External alarms reset (if configured).
14. Press and release the FUNCTION SET YES (+) and NO (-) keys simultaneously, to return to the beginning of the MCA menu tree.

Checking Very Low Voltage Alarm

Procedure:

1. With "SYSTEM OK" being displayed on the MCA Interface Pad, press and release the FUNCTION SET ENTER key.
2. Repeatedly press and release the FUNCTION SELECT DOWN arrow key until ADJUST THE ALARM SETPOINTS is displayed.
3. Press and release the FUNCTION SET ENTER key.
4. Repeatedly press and release the FUNCTION SELECT DOWN arrow key until VERY LOW VOLTAGE = vv.vvV is displayed.
5. Record the value indicated on the display.
6. Press and release the ALARM CUTOFF and FUNCTION SET ENTER keys simultaneously. Line 2 of the display is replaced by "CHANGE THE VARIABLE".
7. Press the FUNCTION SET YES (+) key until the value displayed is increased to above system voltage level, then release the key.
8. Press and release the FUNCTION SET ENTER key.

9. "ARE YOU SURE?" is displayed. Press and release the FUNCTION SET YES (+) key.
 - a) **Requirement:** MCA "MAJOR" indicator flashes red.
 - b) **Requirement:** MCA displays SYSTEM VOLTAGE IS VERY LOW.
 - c) **Requirement:** External alarms activate (if configured).
10. With BATTERY ON DISCHARGE being displayed, press and release the ALARM CUTOFF and FUNCTION SET ENTER keys simultaneously.
11. Press the FUNCTION SET NO (-) key until the value displayed is decreased to the value recorded in step 5) or to the required value for your site, then release the key.
12. Press and release the FUNCTION SET ENTER key.
13. "ARE YOU SURE?" is displayed. Press and release the FUNCTION SET YES (+) key.
 - a) **Requirement:** MCA "MAJOR" indicator goes out.
 - b) **Requirement:** External alarms reset (if configured).
14. Press and release the FUNCTION SET YES (+) and NO (-) keys simultaneously, to return to the beginning of the MCA menu tree.

Checking Total Distribution Load Alarm

Procedure:

1. With "SYSTEM OK" being displayed on the MCA Interface Pad, press and release the FUNCTION SET ENTER key.
2. Repeatedly press and release the FUNCTION SELECT DOWN arrow key until ADJUST THE ALARM SETPOINTS is displayed.
3. Press and release the FUNCTION SET ENTER key.
4. Repeatedly press and release the FUNCTION SELECT DOWN arrow key until TOTAL DISTRIBUTION = aaaaaA is displayed.
5. Record the value indicated on the display.
6. Press and release the ALARM CUTOFF and FUNCTION SET ENTER keys simultaneously. Line 2 of the display is replaced by "CHANGE THE VARIABLE".
7. Press the FUNCTION SET NO (-) key until the value displayed is decreased to below system output current level, then release the key.
8. Press and release the FUNCTION SET ENTER key.
9. "ARE YOU SURE?" is displayed. Press and release the FUNCTION SET YES (+) key.
 - a) **Requirement:** MCA "MINOR" indicator goes red.
 - b) **Requirement:** MCA displays TOTAL DISTRIBUTION LOAD ALARM.
 - c) **Requirement:** External alarms activate (if configured).

10. With TOTAL DISTRIBUTION = aaaaaA being displayed in the ALARM ADJUSTMENT MENU, press and release the ALARM CUTOFF and FUNCTION SET ENTER keys simultaneously.
11. Press the FUNCTION SET YES (+) key until the value displayed is increased to the value recorded in step 5) or to the required value for your site, then release the key.
12. Press and release the FUNCTION SET ENTER key.
13. "ARE YOU SURE?" is displayed. Press and release the FUNCTION SET YES (+) key.
 - a) **Requirement:** MCA "MINOR" indicator goes out.
 - b) **Requirement:** External alarms reset (if configured).
14. Press and release the FUNCTION SET YES (+) and NO (-) keys simultaneously, to return to the beginning of the MCA menu tree.

Checking Distribution Group A Load Alarm

Perform this procedure only if distribution buses are set with A/B designation.

Procedure:

1. With "SYSTEM OK" being displayed on the MCA Interface Pad, press and release the FUNCTION SET ENTER key.
2. Repeatedly press and release the FUNCTION SELECT DOWN arrow key until ADJUST THE ALARM SETPOINTS is displayed.
3. Press and release the FUNCTION SET ENTER key.
4. Repeatedly press and release the FUNCTION SELECT DOWN arrow key until DISTRIBUTION GROUP A = aaaaaA is displayed.
5. Record the value indicated on the display.
6. Press and release the ALARM CUTOFF and FUNCTION SET ENTER keys simultaneously. Line 2 of the display is replaced by "CHANGE THE VARIABLE".
7. Press the FUNCTION SET NO (-) key until the value displayed is decreased to below Group A output current level, then release the key.
8. Press and release the FUNCTION SET ENTER key.
9. "ARE YOU SURE?" is displayed. Press and release the FUNCTION SET YES (+) key.
 - a) **Requirement:** MCA "MINOR" indicator goes red.
 - b) **Requirement:** MCA displays DISTRIBUTION GROUP A LOAD ALARM.
 - c) **Requirement:** External alarms activate (if configured).
10. With DISTRIBUTION GROUP A = aaaaaA being displayed in the ALARM ADJUSTMENT MENU, press and release the ALARM CUTOFF and FUNCTION SET ENTER keys simultaneously.
11. Press the FUNCTION SET YES (+) key until the value displayed is increased to the value recorded in step 5) or to the required value for your site, then release the key.

12. Press and release the FUNCTION SET ENTER key.
13. "ARE YOU SURE?" is displayed. Press and release the FUNCTION SET YES (+) key.
 - a) **Requirement:** MCA "MINOR" indicator goes out.
 - b) **Requirement:** External alarms reset (if configured).
14. Press and release the FUNCTION SET YES (+) and NO (-) keys simultaneously, to return to the beginning of the MCA menu tree.

Checking Distribution Group B Load Alarm

Perform this procedure only if distribution buses are set with A/B designation.

Procedure:

1. With "SYSTEM OK" being displayed on the MCA Interface Pad, press and release the FUNCTION SET ENTER key.
2. Repeatedly press and release the FUNCTION SELECT DOWN arrow key until ADJUST THE ALARM SETPOINTS is displayed.
3. Press and release the FUNCTION SET ENTER key.
4. Repeatedly press and release the FUNCTION SELECT DOWN arrow key until DISTRIBUTION GROUP B = aaaaaA is displayed.
5. Record the value indicated on the display.
6. Press and release the ALARM CUTOFF and FUNCTION SET ENTER keys simultaneously. Line 2 of the display is replaced by "CHANGE THE VARIABLE".
7. Press the FUNCTION SET NO (-) key until the value displayed is decreased to below Group B output current level, then release the key.
8. Press and release the FUNCTION SET ENTER key.
9. "ARE YOU SURE?" is displayed. Press and release the FUNCTION SET YES (+) key.
 - a) **Requirement:** MCA "MINOR" indicator goes red.
 - b) **Requirement:** MCA displays DISTRIBUTION GROUP B LOAD ALARM.
 - c) **Requirement:** External alarms activate (if configured).
10. With DISTRIBUTION GROUP B = aaaaaA being displayed in the ALARM ADJUSTMENT MENU, press and release the ALARM CUTOFF and FUNCTION SET ENTER keys simultaneously.
11. Press the FUNCTION SET YES (+) key until the value displayed is increased to the value recorded in step 5) or to the required value for your site, then release the key.
12. Press and release the FUNCTION SET ENTER key.
13. "ARE YOU SURE?" is displayed. Press and release the FUNCTION SET YES (+) key.
 - a) **Requirement:** MCA "MINOR" indicator goes out.

- b) **Requirement:** External alarms reset (if configured).
- 14. Press and release the FUNCTION SET YES (+) and NO (-) keys simultaneously, to return to the beginning of the MCA menu tree.

Checking Fuse Alarm/Circuit Breaker Alarm

Procedure:

1. Ensure that all circuit breakers are in the ON position.
2. Remove an alarm-type fuse from a distribution fuse module, and replace with a known open fuse.
 - a) **Requirement:** The bay's "Bay Alarm" indicator goes red.
 - b) **Requirement:** The distribution panel's "CBA/FA" indicator goes red.
 - c) **Requirement:** MCA "MAJOR" indicator flashes red.
 - d) **Requirement:** MCA displays 1 SYSTEM BREAKER OR FUSE ALARM.
 - e) **Requirement:** External alarms activate (if configured).
3. Replace the open fuse with a known good fuse.
 - a) **Requirement:** The bay's "Bay Alarm" indicator goes out.
 - b) **Requirement:** The distribution panel's "CBA/FA" indicator goes out.
 - c) **Requirement:** MCA "MAJOR" indicator goes out.
 - d) **Requirement:** MCA displays SYSTEM OK message.
 - e) **Requirement:** External alarms reset (if configured).
4. Perform steps 2) and 3) for each remaining distribution fuse module located in the system.

 **NOTE!** *The following procedure is to be used only with circuit breakers that provide an alarm indication when manually placed to the OFF (open) position. Electrical trip alarm circuit breakers cannot be easily tested in the field.*

5. Place a distribution circuit breaker to the OFF position.
 - a) **Requirement:** The bay's "Bay Alarm" indicator goes red.
 - b) **Requirement:** The distribution panel's "CBA/FA" indicator goes red.
 - c) **Requirement:** MCA "MAJOR" indicator flashes red.
 - d) **Requirement:** MCA displays 1 SYSTEM BREAKER OR FUSE ALARM.
 - e) **Requirement:** External alarms activate (if configured).
6. Place the circuit breaker back to the ON position.
 - a) **Requirement:** The bay's "Bay Alarm" indicator goes out.
 - b) **Requirement:** The distribution panel's "CBA/FA" indicator goes out.

- c) **Requirement:** MCA “MAJOR” indicator goes out.
 - d) **Requirement:** MCA displays SYSTEM OK message.
 - e) **Requirement:** External alarms reset (if configured).
7. Perform steps 5) and 6) for each remaining distribution circuit breaker located in the system.

Checking Metering Functions

Procedure:

1. With SYSTEM OK being displayed on the MCA Interface Pad, press and release the FUNCTION SET ENTER key.
2. VIEW THE SYSTEM MEASUREMENTS is displayed. Press and release the FUNCTION SET ENTER key.
 - a) **Requirement:** System output sense voltage is displayed.

Press and release the FUNCTION SET ENTER key.

- a) **Requirement:** External sense input voltage is displayed.
3. Repeatedly press and release the FUNCTION SELECT DOWN arrow key to display the sense voltage reported by each bay's router.
 - a) **Requirement:** As the FUNCTION SELECT DOWN arrow key is pressed and released, router sense voltages are displayed. When all router's are cycled through, GO TO MEASUREMENT MENU is displayed.
 4. With GO TO MEASUREMENT MENU being displayed, press and release the FUNCTION SET ENTER key.
 5. Press and release the FUNCTION SELECT DOWN arrow key.
 - a) **Requirement:** Total distribution load current is displayed.
 6. Press and release the FUNCTION SET ENTER key.
 - a) **Requirement:** The load current of the first Distribution Panel is displayed.
 7. Press and release the FUNCTION SET ENTER key.
 - a) **Requirement:** The load current of the first Distribution Device in the Distribution Panel is displayed.
 8. Repeatedly press and release the FUNCTION SELECT DOWN arrow key to display individual load currents through the remaining Distribution Devices.
 - a) **Requirement:** As the FUNCTION SELECT DOWN arrow key is pressed and released, load currents through the remaining Distribution Devices are displayed. When all Distribution Devices are cycled through, GO TO DISTRIBUTION LOAD MENU is displayed.
 9. With GO TO DISTRIBUTION LOAD MENU being displayed, press and release the FUNCTION SET ENTER key.
 10. Repeatedly press and release the FUNCTION SELECT DOWN arrow key and FUNCTION SET ENTER key to display the load currents through the remaining Distribution Panels and Distribution Devices.

11. Navigate to the DISTRIBUTION LOAD MENU.
12. Repeatedly press and release the FUNCTION SELECT DOWN arrow key to display individual load currents of any MCA I/O circuit card set as DISTRIBUTION.
13. When done, navigate to GO TO MEASUREMENT MENU in the DISTRIBUTION LOAD MENU.
14. With GO TO MEASUREMENT MENU being displayed, press and release the FUNCTION SET ENTER key.
15. Press and release the FUNCTION SELECT DOWN arrow key.
 - a) **Requirement:** Distribution Group A load current is displayed.
16. Press and release the FUNCTION SELECT DOWN arrow key.
 - a) **Requirement:** Distribution Group B load current is displayed.
17. Press and release the FUNCTION SELECT DOWN arrow key.
 - a) **Requirement:** Total auxiliary load current is displayed.
18. Press and release the FUNCTION SET ENTER key.
 - a) **Requirement:** The load current of the first MCA I/O circuit card set as AUXILIARY is displayed.
19. Repeatedly press and release the FUNCTION SELECT DOWN arrow key to display individual load currents of any MCA I/O circuit card set as AUXILIARY.
20. When done, navigate to GO TO MEASUREMENT MENU in the DISTRIBUTION LOAD MENU.
21. With GO TO MEASUREMENT MENU being displayed, press and release the FUNCTION SET ENTER key.
22. Press and release the FUNCTION SELECT DOWN arrow key.
 - a) **Requirement:** Total Rectifier Module output current is displayed.
23. Please Note: Due to small differences in calibration between Rectifier Modules and the Distribution Shunts, this value may not be equal to that seen in Step 6).
24. Press and release the FUNCTION SET ENTER key.
 - a) **Requirement:** Output current of the first Rectifier Module is displayed.
25. Repeatedly press and release the FUNCTION SELECT DOWN arrow key to display individual output currents of the remaining Rectifier Modules.
 - a) **Requirement:** As the FUNCTION SELECT DOWN arrow key is pressed and released, output currents of the remaining Rectifier Modules are displayed. When all Rectifier Modules are cycled through, GO TO MEASUREMENT MENU is displayed.
26. With GO TO MEASUREMENT MENU being displayed, press and release the FUNCTION SET ENTER key.
27. Press and release the FUNCTION SELECT DOWN arrow key.

- a) **Requirement:** Temperature sensor (if installed) temperature is displayed.
28. Press and release the FUNCTION SET YES (+) and NO (-) keys simultaneously, to return to the beginning of the MCA menu tree.

Checking System Status

Procedure: Verify the state of the following system status indications.

MCA Interface Pad:

- a) **Requirement:** MCA displays SYSTEM OK message.
- b) **Requirement:** MINOR indicator off.
- c) **Requirement:** MAJOR indicator off.
- d) **Requirement:** AC indicator green.
- e) **Requirement:** TEST/EQ indicator off.
- f) **Requirement:** ALARM CUTOFF indicator off.

Rectifier Module:

- a) **Requirement:** POWER indicator green.
- b) **Requirement:** PROTECTION indicator off.
- c) **Requirement:** ALARM indicator off.

Power Bay:

- a) **Requirement:** BAY ALARM indicator green.
(located on outside of door at top)
- b) **Requirement:** POWER indicator green.
(located inside bay, center section)
- c) **Requirement:** FA indicator off.
(located inside bay, center section)
- d) **Requirement:** Status indicator located on the following circuit cards green.
 - MCA/Router circuit card
 - LMS CPU circuit card (if installed)
 - MCA Customer Alarm Relay circuit card (if installed)

Distribution Bay:

- a) **Requirement:** BAY ALARM indicator green.
(located on outside of door at top)
- b) **Requirement:** Distribution Bus indicator green.
(located on hinged panel covering
MCA Distribution Bus Monitoring circuit cards)
- c) **Requirement:** POWER indicator green.
(located inside bay, top section)

- d) **Requirement:** FA indicator off.
(located inside bay, top section)
- e) **Requirement:** Status indicator located on the following circuit cards green.
 - Router circuit card
 - MCA Distribution Bus Monitoring circuit cards

Checking and Configuring THE LMS System

Refer to the separate LMS Installation Instructions (Section 5879). Section 5879 can be accessed from the CD (Electronic Documentation Package) furnished with your system.

