

**FRONT VIEW**

EXTERNAL BATTERY  
CABINET DETECTION  
TERMINALS

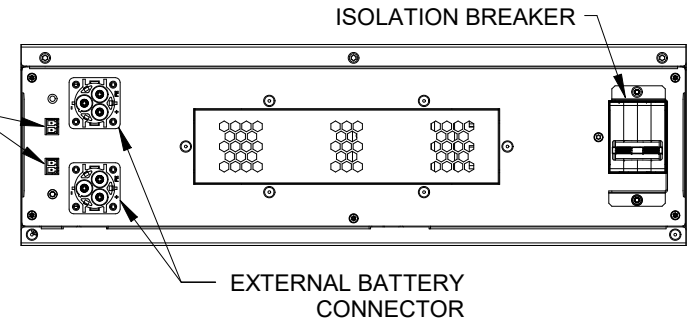

**REAR VIEW**

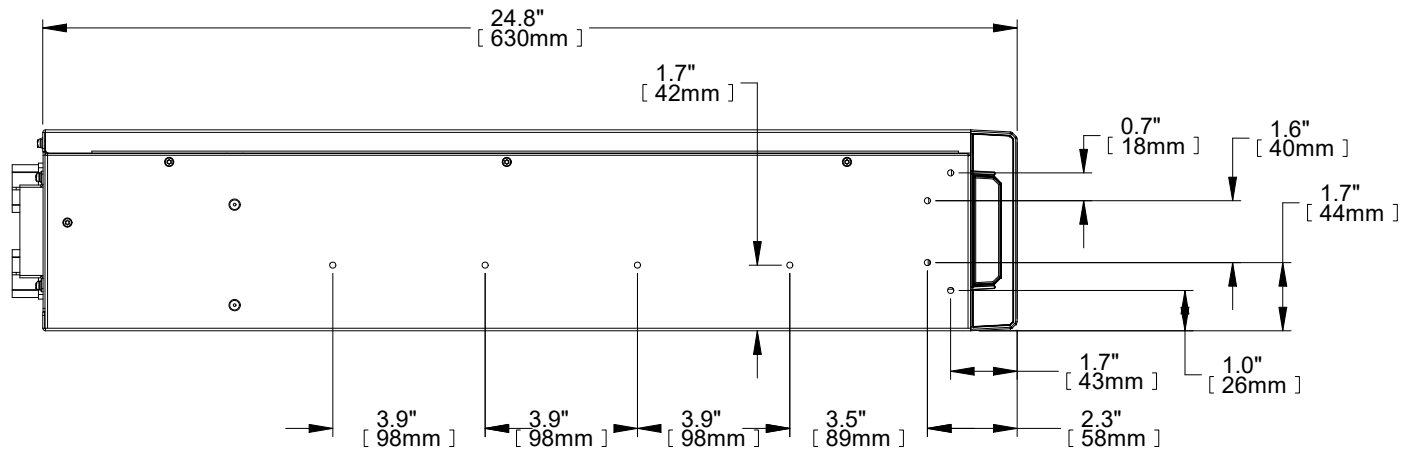

**SIDE VIEW**

**NOTES:**

1. UNIT DIMENSIONS (WxDxH): 16.9" x 24.8" x 5.1" (3U)  
(430mm) x (630mm) x (130mm)
2. UNIT WEIGHT: 127lbs (57.6kg)
3. SHIPPING DIMENSIONS (WxDxH): 33" x 26.4" x 18.3"  
(840mm) x (670mm) x (465mm)
4. SHIPPING WEIGHT: 246.9lbs (112kg)
5. MINIMUM AIRFLOW CLEARANCE IS 4.0" (100mm) FRONT AND REAR.

DRAWN BY B. LAY	SHEET NO. 1 OF 1
CHK BY M. MCCLINCY	ECN NO.
REF. DWG.	ORDER NO.

OUTLINE DRAWING  
LIEBERT GXT5  
192V EXTERNAL BATTERY CABINET

DWG. NO. GXT5-192VEBC OD	DATE 1/30/19	REV. # 0	1050 DEARBORN DRIVE P.O. BOX 29186 COLUMBUS, OHIO 43229
-----------------------------	-----------------	-------------	---

